



## **ns-3 Model Library**

*Release ns-3.15*

**ns-3 project**

November 13, 2012



# CONTENTS

<b>1</b>	<b>Organization</b>	<b>3</b>
<b>2</b>	<b>Animation</b>	<b>5</b>
2.1	NetAnim . . . . .	5
<b>3</b>	<b>Antenna Module</b>	<b>17</b>
3.1	Design documentation . . . . .	17
3.2	User Documentation . . . . .	18
3.3	Testing Documentation . . . . .	19
<b>4</b>	<b>Ad Hoc On-Demand Distance Vector (AODV)</b>	<b>21</b>
4.1	Model Description . . . . .	21
4.2	Usage . . . . .	23
4.3	Validation . . . . .	23
<b>5</b>	<b>Applications</b>	<b>25</b>
<b>6</b>	<b>Bridge NetDevice</b>	<b>27</b>
<b>7</b>	<b>Buildings Module</b>	<b>29</b>
7.1	Design documentation . . . . .	29
7.2	User Documentation . . . . .	34
7.3	Testing Documentation . . . . .	35
7.4	References . . . . .	38
<b>8</b>	<b>Click Modular Router Integration</b>	<b>39</b>
8.1	Model Description . . . . .	39
8.2	Usage . . . . .	40
8.3	Validation . . . . .	42
<b>9</b>	<b>CSMA NetDevice</b>	<b>43</b>
9.1	Overview of the CSMA model . . . . .	43
9.2	CSMA Channel Model . . . . .	44
9.3	CSMA Net Device Model . . . . .	45
9.4	Using the CsmNetDevice . . . . .	46
9.5	CSMA Tracing . . . . .	47
9.6	Summary . . . . .	48
<b>10</b>	<b>DSDV Routing</b>	<b>49</b>
10.1	DSDV Routing Overview . . . . .	49

10.2	References	50
<b>11</b>	<b>DSR Routing</b>	<b>51</b>
11.1	DSR Routing Overview	51
11.2	DSR Instructions	53
11.3	Helper	53
11.4	Examples	53
11.5	Validation	53
11.6	References	54
<b>12</b>	<b>Emulation Overview</b>	<b>55</b>
12.1	Emu NetDevice	56
12.2	Tap NetDevice	61
<b>13</b>	<b>Energy Framework</b>	<b>67</b>
13.1	Model Description	67
13.2	Usage	68
<b>14</b>	<b>Flow Monitor</b>	<b>71</b>
<b>15</b>	<b>Internet Models</b>	<b>73</b>
15.1	Internet Stack	73
15.2	IPv4	76
15.3	IPv6	76
15.4	Routing overview	78
15.5	TCP models in ns-3	84
<b>16</b>	<b>LTE Module</b>	<b>91</b>
16.1	Design Documentation	91
16.2	User Documentation	124
16.3	Testing Documentation	140
16.4	Profiling Documentation	151
16.5	References	157
<b>17</b>	<b>Mesh NetDevice</b>	<b>159</b>
<b>18</b>	<b>MPI for Distributed Simulation</b>	<b>161</b>
18.1	Current Implementation Details	161
18.2	Running Distributed Simulations	162
18.3	Tracing During Distributed Simulations	164
<b>19</b>	<b>Mobility</b>	<b>165</b>
19.1	Model Description	165
19.2	Usage	168
19.3	Validation	169
<b>20</b>	<b>Network Module</b>	<b>171</b>
20.1	Packets	171
20.2	Node and NetDevices Overview	182
20.3	Sockets APIs	183
20.4	Simple NetDevice	186
20.5	Queues	186
<b>21</b>	<b>Optimized Link State Routing (OLSR)</b>	<b>191</b>
21.1	Model Description	191
21.2	Usage	192

21.3	Validation . . . . .	192
<b>22</b>	<b>OpenFlow switch support</b>	<b>193</b>
22.1	Model Description . . . . .	193
22.2	Usage . . . . .	194
22.3	Validation . . . . .	196
<b>23</b>	<b>PointToPoint NetDevice</b>	<b>197</b>
23.1	Overview of the PointToPoint model . . . . .	197
23.2	Point-to-Point Channel Model . . . . .	198
23.3	Using the PointToPointNetDevice . . . . .	198
23.4	PointToPoint Tracing . . . . .	198
<b>24</b>	<b>Propagation</b>	<b>201</b>
24.1	PropagationLossModel . . . . .	201
24.2	PropagationDelayModel . . . . .	205
<b>25</b>	<b>Statistical Framework</b>	<b>207</b>
25.1	Goals . . . . .	207
25.2	Overview . . . . .	207
25.3	To-Do . . . . .	208
25.4	Approach . . . . .	208
25.5	Example . . . . .	209
<b>26</b>	<b>Topology Input Readers</b>	<b>217</b>
<b>27</b>	<b>UAN Framework</b>	<b>219</b>
27.1	Model Description . . . . .	219
27.2	Usage . . . . .	225
27.3	Validation . . . . .	228
<b>28</b>	<b>Wifi</b>	<b>231</b>
28.1	Overview of the model . . . . .	231
28.2	Using the WifiNetDevice . . . . .	232
28.3	The WifiChannel and WifiPhy models . . . . .	236
28.4	The MAC model . . . . .	237
28.5	Wifi Attributes . . . . .	237
28.6	Wifi Tracing . . . . .	238
28.7	References . . . . .	238
<b>29</b>	<b>Wimax NetDevice</b>	<b>239</b>
29.1	Scope of the model . . . . .	239
29.2	Using the Wimax models . . . . .	240
29.3	Wimax Attributes . . . . .	241
29.4	Wimax Tracing . . . . .	242
29.5	Wimax MAC model . . . . .	242
29.6	WimaxChannel and WimaxPhy models . . . . .	246
29.7	Channel model . . . . .	246
29.8	Physical model . . . . .	246
	<b>Bibliography</b>	<b>249</b>



This is the *ns-3 Model Library* documentation. Primary documentation for the ns-3 project is available in five forms:

- [ns-3 Doxygen](#): Documentation of the public APIs of the simulator
- Tutorial, Manual, and Model Library (*this document*) for the [latest release](#) and [development tree](#)
- [ns-3 wiki](#)

This document is written in [reStructuredText](#) for [Sphinx](#) and is maintained in the `doc/models` directory of ns-3's source code.





# ORGANIZATION

This manual compiles documentation for *ns-3* models and supporting software that enable users to construct network simulations. It is important to distinguish between **modules** and **models**:

- *ns-3* software is organized into separate *modules* that are each built as a separate software library. Individual *ns-3* programs can link the modules (libraries) they need to conduct their simulation.
- *ns-3 models* are abstract representations of real-world objects, protocols, devices, etc.

An *ns-3* module may consist of more than one model (for instance, the `internet` module contains models for both TCP and UDP). In general, *ns-3* models do not span multiple software modules, however.

This manual provides documentation about the models of *ns-3*. It complements two other sources of documentation concerning models:

- the model APIs are documented, from a programming perspective, using [Doxygen](#). Doxygen for *ns-3* models is available [on the project web server](#).
- the *ns-3* core is documented in the developer's manual. *ns-3* models make use of the facilities of the core, such as attributes, default values, random numbers, test frameworks, etc. Consult the [main web site](#) to find copies of the manual.

Finally, additional documentation about various aspects of *ns-3* may exist on the [project wiki](#).

A sample outline of how to write model library documentation can be found in `src/template/doc`.

The remainder of this document is organized alphabetically by module name.

If you are new to *ns-3*, you might first want to read below about the network module, which contains some fundamental models for the simulator. The packet model, models for different address formats, and abstract base classes for objects such as nodes, net devices, channels, sockets, and applications are discussed there.



# ANIMATION

Animation is an important tool for network simulation. While *ns-3* does not contain a default graphical animation tool, we currently have two ways to provide animation, namely using the PyViz method or the NetAnim method. The PyViz method is described in <http://www.nsnam.org/wiki/index.php/PyViz>.

We will describe the NetAnim method briefly here.

## 2.1 NetAnim

NetAnim is a standalone, Qt4-based software executable that uses a trace file generated during an *ns-3* simulation to display the topology and animate the packet flow between nodes.

In addition, NetAnim also provides useful features such as tables to display meta-data of packets like the image below and a way to visualize the trajectory of a mobile node

### 2.1.1 Methodology

The class `ns3::AnimationInterface` is responsible for the creation the trace XML file. `AnimationInterface` uses the tracing infrastructure to track packet flows between nodes. `AnimationInterface` registers itself as a trace hook for tx and rx events before the simulation begins. When a packet is scheduled for transmission or reception, the corresponding tx and rx trace hooks in `AnimationInterface` are called. When the rx hooks are called, `AnimationInterface` will be aware of the two endpoints between which a packet has flowed, and adds this information to the trace file, in XML format along with the corresponding tx and rx timestamps. The XML format will be discussed in a later section. It is important to note that `AnimationInterface` records a packet only if the rx trace hooks are called. Every tx event must be matched by an rx event.

### 2.1.2 Downloading NetAnim

If NetAnim is not already available in the *ns-3* package you downloaded, you can do the following:

Please ensure that you have installed mercurial. The latest version of NetAnim can be downloaded using mercurial with the following command:

```
hg clone http://code.nsnam.org/netanim
```

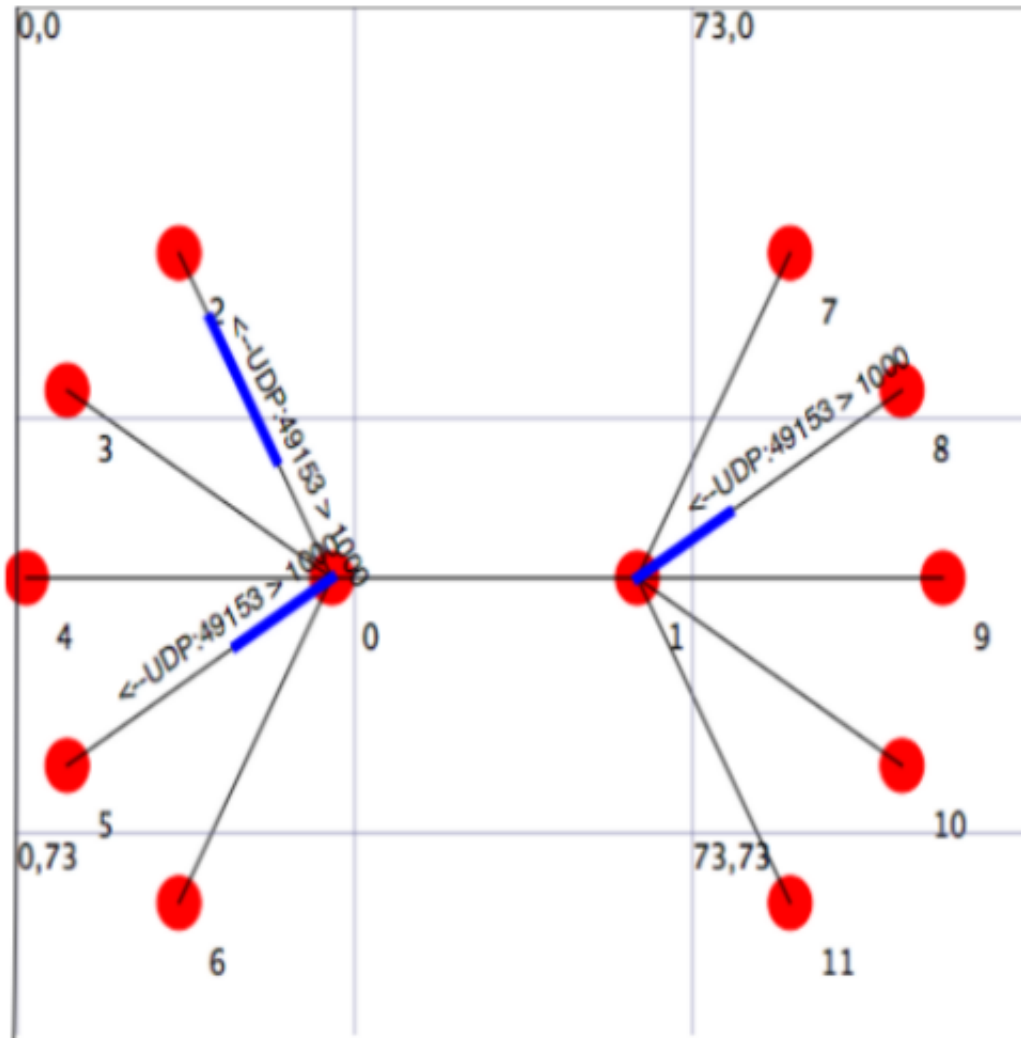

Figure 2.1: An example of packet animation on wired-links

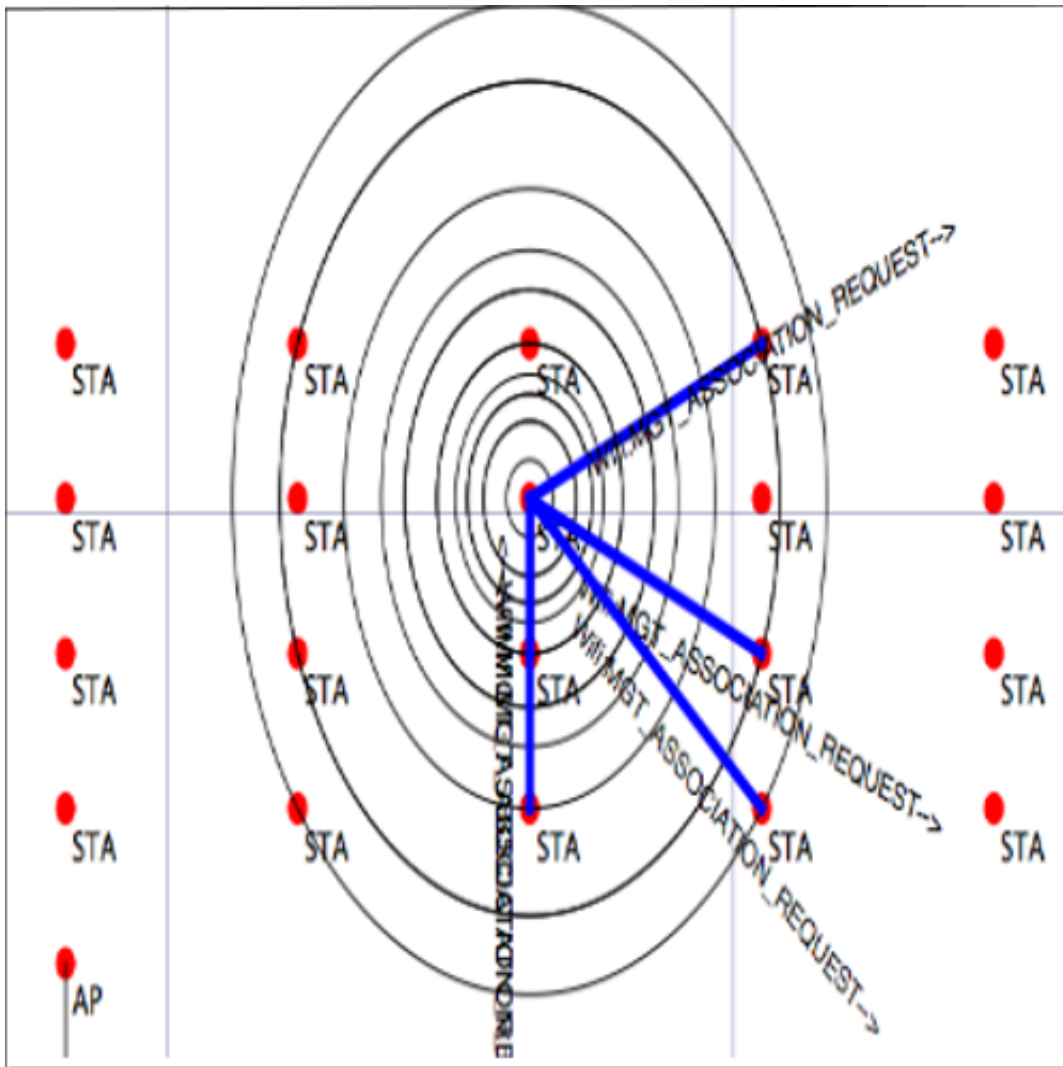

Figure 2.2: An example of packet animation on wireless-links

Packet count		Tx Time				From Node Id				To Node Id				Meta Info				
Packet count	11208	1	0.0301008	1	0	1	0	1	0	1	0	1	0	TCP 50000 > 49153 SYN ACK Seq=0 Ack=1 Win=65535	1	0	1	0
From Node Id	1	2	0.0711264	1	0	1	0	1	0	1	0	1	0	TCP 50000 > 49153 ACK Seq=1 Ack=537 Win=65535	1	0	1	0
To Node Id	0	3	0.112581	1	0	1	0	1	0	1	0	1	0	TCP 50000 > 49153 ACK Seq=1 Ack=1609 Win=65535	1	0	1	0
Transmission time >=	0	4	0.154035	1	0	1	0	1	0	1	0	1	0	TCP 50000 > 49153 ACK Seq=1 Ack=2681 Win=65535	1	0	1	0
	Apply filter	5	0.195027	1	0	1	0	1	0	1	0	1	0	TCP 50000 > 49153 ACK Seq=1 Ack=3753 Win=65535	1	0	1	0
	Select All	6	0.195952	1	0	1	0	1	0	1	0	1	0	TCP 50000 > 49153 ACK Seq=1 Ack=4825 Win=65535	1	0	1	0
	DeSelect All	7	0.236482	1	0	1	0	1	0	1	0	1	0	TCP 50000 > 49153 ACK Seq=1 Ack=5897 Win=65535	1	0	1	0
<input type="checkbox"/> All Packets		8	0.237406	1	0	1	0	1	0	1	0	1	0	TCP 50000 > 49153 ACK Seq=1 Ack=6969 Win=65535	1	0	1	0
<input type="checkbox"/> Ethernet		9	0.238331	1	0	1	0	1	0	1	0	1	0	TCP 50000 > 49153 ACK Seq=1 Ack=8041 Win=65535	1	0	1	0
<input type="checkbox"/> Ppp		10	0.277936	1	0	1	0	1	0	1	0	1	0	TCP 50000 > 49153 ACK Seq=1 Ack=9113 Win=65535	1	0	1	0
<input type="checkbox"/> Wifi		11	0.278861	1	0	1	0	1	0	1	0	1	0	TCP 50000 > 49153 ACK Seq=1 Ack=10185 Win=65535	1	0	1	0
<input type="checkbox"/> Arp		12	0.279786	1	0	1	0	1	0	1	0	1	0	TCP 50000 > 49153 ACK Seq=1 Ack=11257 Win=65535	1	0	1	0
<input type="checkbox"/> Ipv4		13	0.28071	1	0	1	0	1	0	1	0	1	0	TCP 50000 > 49153 ACK Seq=1 Ack=12329 Win=65535	1	0	1	0
<input type="checkbox"/> Icmpv4		14	0.318928	1	0	1	0	1	0	1	0	1	0	TCP 50000 > 49153 ACK Seq=1 Ack=13401 Win=65535	1	0	1	0
<input type="checkbox"/> Udp		15	0.319853	1	0	1	0	1	0	1	0	1	0	TCP 50000 > 49153 ACK Seq=1 Ack=14473 Win=65535	1	0	1	0
<input checked="" type="checkbox"/> Tcp		16	0.320778	1	0	1	0	1	0	1	0	1	0	TCP 50000 > 49153 ACK Seq=1 Ack=15545 Win=65535	1	0	1	0
<input type="checkbox"/> Aodv		17	0.321702	1	0	1	0	1	0	1	0	1	0	TCP 50000 > 49153 ACK Seq=1 Ack=16617 Win=65535	1	0	1	0
<input type="checkbox"/> Olsr		18	0.322627	1	0	1	0	1	0	1	0	1	0	TCP 50000 > 49153 ACK Seq=1 Ack=17689 Win=65535	1	0	1	0
<input type="checkbox"/> Dsdv		19	0.323552	1	0	1	0	1	0	1	0	1	0	TCP 50000 > 49153 ACK Seq=1 Ack=18761 Win=65535	1	0	1	0
		20	0.35992	1	0	1	0	1	0	1	0	1	0	TCP 50000 > 49153 ACK Seq=1 Ack=19833 Win=65535	1	0	1	0
		21	0.360845	1	0	1	0	1	0	1	0	1	0	TCP 50000 > 49153 ACK Seq=1 Ack=20905 Win=65535	1	0	1	0
		22	0.36177	1	0	1	0	1	0	1	0	1	0	TCP 50000 > 49153 ACK Seq=1 Ack=21977 Win=65535	1	0	1	0
		23	0.362694	1	0	1	0	1	0	1	0	1	0	TCP 50000 > 49153 ACK Seq=1 Ack=23049 Win=65535	1	0	1	0

Figure 2.3: An example of tables for packet meta-data with protocol filters

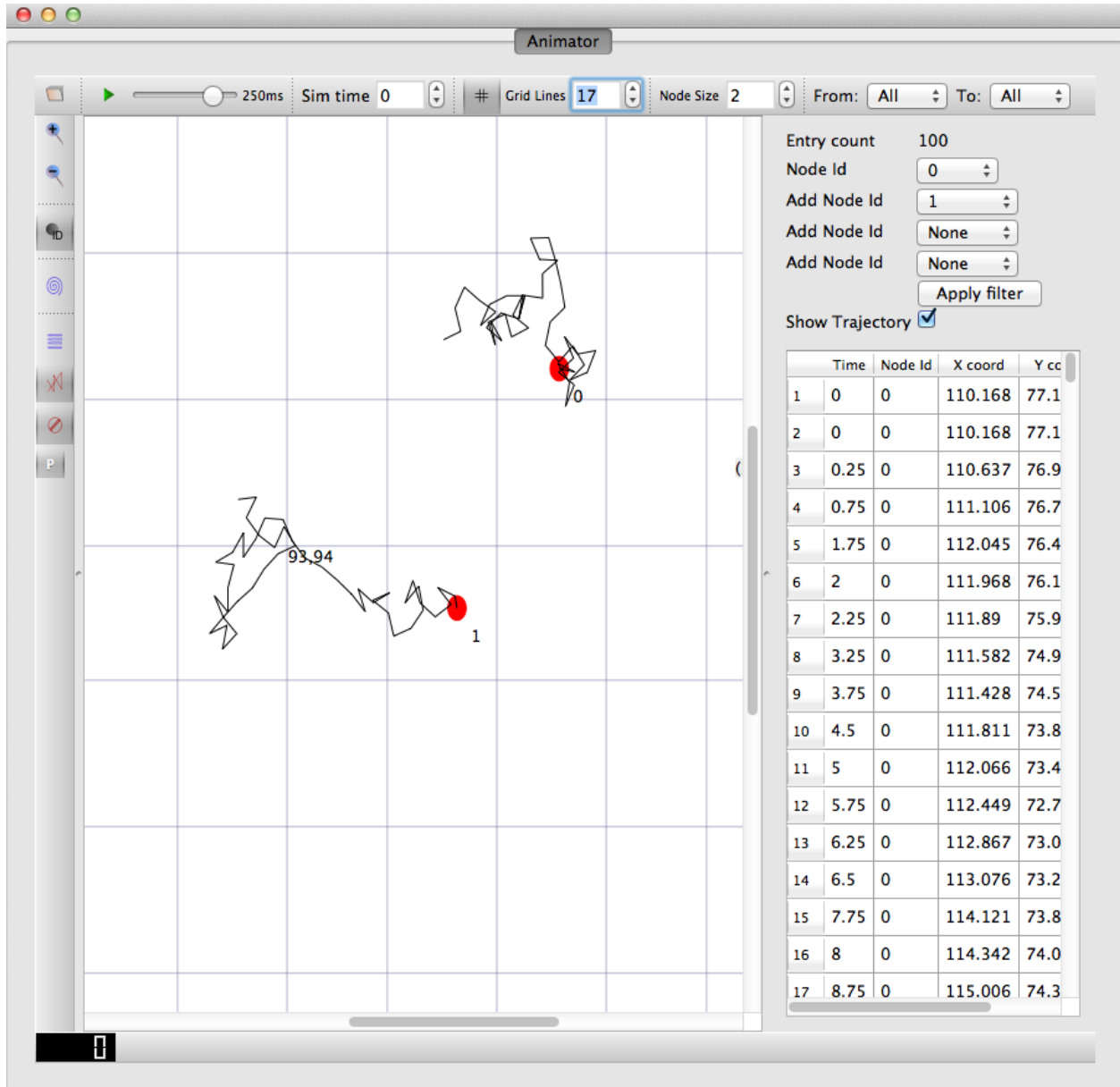

Figure 2.4: An example of the trajectory of a mobile node

## 2.1.3 Building NetAnim

### Prerequisites

Qt4 (4.7 and over) is required to build NetAnim. This can be obtained using the following ways:

For Debian/Ubuntu Linux distributions:

```
apt-get install qt4-dev-tools
```

For Red Hat/Fedora based distribution:

```
yum install qt4
yum install qt4-devel
```

For Mac/OSX:

<http://qt.nokia.com/downloads/>

### Build steps

To build NetAnim use the following commands:

```
cd netanim
make clean
qmake NetAnim.pro (For MAC Users: qmake -spec macx-g++ NetAnim.pro)
make
```

Note: qmake could be “qmake-qt4” in some systems

This should create an executable named “NetAnim” in the same directory:

```
john@john-VirtualBox:~/netanim$ ls -l NetAnim
-rwxr-xr-x 1 john john 390395 2012-05-22 08:32 NetAnim
```

## 2.1.4 Usage

Using NetAnim is a two-step process

Step 1:Generate the animation XML trace file during simulation using “ns3::AnimationInterface” in the *ns-3* code base.

Step 2:Load the XML trace file generated in Step 1 with the offline Qt4-based animator named NetAnim.

### Step 1: Generate XML animation trace file

The class “AnimationInterface” under “src/netanim” uses underlying *ns-3* trace sources to construct a timestamped ASCII file in XML format.

Examples are found under `src/netanim/examples` Example:

```
./waf -d debug configure --enable-examples
./waf --run "dumbbell-animation"
```

The above will create an XML file `dumbbell-animation.xml`



## Mandatory

1. Ensure that your program's wscript includes the "netanim" module. An example of such a wscript is at `src/netanim/examples/wscript`.
2. Include the header `["#include "ns3/netanim-module.h"]` in your test program
3. Add the statement

```
AnimationInterface anim ("animation.xml");
where "animation.xml" is any arbitrary filename
```

[for versions before ns-3.13 you also have to use the line "anim.SetXMLOutput() to set the XML mode and also use anim.StartAnimation();]

## Optional

The following are optional but useful steps:

```
1. anim.SetMobilityPollInterval (Seconds (1));
```

AnimationInterface records the position of all nodes every 250 ms by default. The statement above sets the periodic interval at which AnimationInterface records the position of all nodes. If the nodes are expected to move very little, it is useful to set a high mobility poll interval to avoid large XML files.

```
2. anim.SetConstantPosition (Ptr< Node > n, double x, double y);
```

AnimationInterface requires that the position of all nodes be set. In *ns-3* this is done by setting an associated MobilityModel. "SetConstantPosition" is a quick way to set the x-y coordinates of a node which is stationary.

```
3. anim.SetStartTime (Seconds(150)); and anim.SetStopTime (Seconds(150));
```

AnimationInterface can generate large XML files. The above statements restricts the window between which AnimationInterface does tracing. Restricting the window serves to focus only on relevant portions of the simulation and creating manageably small XML files

```
4. AnimationInterface anim ("animation.xml", 50000);
```

Using the above constructor ensures that each animation XML trace file has only 50000 packets. For example, if AnimationInterface captures 150000 packets, using the above constructor splits the capture into 3 files

animation.xml - containing the packet range 1-50000

animation.xml-1 - containing the packet range 50001-100000

animation.xml-2 - containing the packet range 100001-150000

```
5. anim.EnablePacketMetadata (true);
```

With the above statement, AnimationInterface records the meta-data of each packet in the xml trace file. Metadata can be used by NetAnim to provide better statistics and filter, along with providing some brief information about the packet such as TCP sequence number or source & destination IP address during packet animation.

CAUTION: Enabling this feature will result in larger XML trace files. Please do NOT enable this feature when using Wimax links.

## Step 2: Loading the XML in NetAnim

1. Assuming NetAnim was built, use the command `./NetAnim` to launch NetAnim. Please review the section “Building NetAnim” if NetAnim is not available.
2. When NetAnim is opened, click on the File open button at the top-left corner, select the XML file generated during Step 1.
3. Hit the green play button to begin animation.

Here is a video illustrating this [http://www.youtube.com/watch?v=tz\\_hUuNwFDs](http://www.youtube.com/watch?v=tz_hUuNwFDs)

## 2.1.5 Essential settings of NetAnim

### Persist combobox



Figure 2.5: The persist combobox

When packets are transmitted and received very quickly, they can be almost invisible. The persist time setting allows the user to control the duration for which a packet should be visible on the animation canvas.

### Fast-forward button



Figure 2.6: The Fast-forward button

This setting is ON by default. With this setting ON, the animation progresses in simulation time rather than wall-clock time. This means, if there were three intervals of time, A to B, B to C and C to D, and if all packets are transmitted and received only in the intervals A to B and C to D, while B to C is a 20 second idle period with no packet transmission or reception or node mobility, NetAnim will skip over B to C, instantly without waiting for 20 seconds. The user can turn OFF Fast-forward when they want the animation to proceed like wall-clock time.

### Update-interval slider



Figure 2.7: The update-interval slider

If Fast-forward (discussed above) is turned OFF, the update-interval slider controls the rate at which NetAnim refreshes the canvas screen. For instance, for the setting above, NetAnim, updates the position of nodes and packets only once in 250 ms.



Figure 2.8: The precision button

### Precision button

This setting is turned OFF by default. When using purely point-to-point topologies precision can be turned ON, to distinguish between small and large packets travelling on a link. For instance a small packet such as a TCP ACK segment occupies only a small fraction of the length of the link, which provides a realistic animation.

CAUTION: Precision should be turned ON only for completely point-to-point topologies.

The below two images show the difference between packet link animation for the case without precision and for the case with precision. The one with precision ON, shows that the SYN segment does not occupy the full link, because they are small packets. This provides a better visualization.

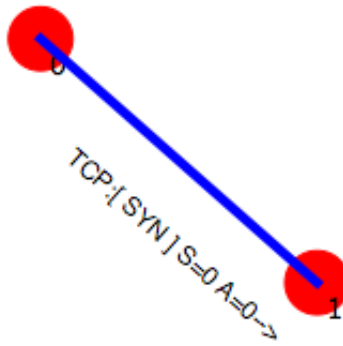

Figure 2.9: Without precision

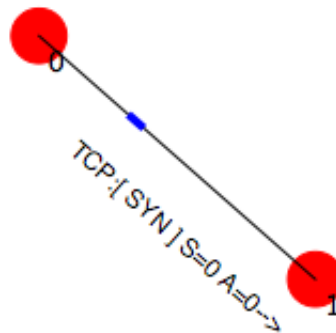

Figure 2.10: With precision

### Sim-time spinbox

The Sim-time spinbox can be used to go forward or backward in simulation time.

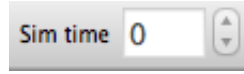

Figure 2.11: The Sim-time spinbox

## 2.1.6 Parts of the XML

The XML trace files has the following main sections

1. Topology
  - Nodes
  - Links
2. packets (packets over wired-links)
3. wpackets (packets over wireless-links)

### XML tags

Nodes are identified by their unique Node id. The XML begins with the “information” element describing the rest of the elements

1. <anim> element

**This is the XML root element. All other elements fall within this element.** Attributes are:

lp = Logical Processor Id (Used for distributed simulations only)

2. <topology> element

**This elements contains the Node and Link elements.It describes, the co-ordinates of the canvas used for animation.**

Attributes are:

minX = minimum X coordinate of the animation canvas  
minY = minimum Y coordinate of the animation canvas  
maxX = maximum X coordinate of the animation canvas  
maxY = maximum Y coordinate of the animation canvas

Example:

```
<topology minX = "-6.42025" minY = "-6.48444" maxX = "186.187" maxY = "188.049">
```

3. <node> element

**This element describes each Node’s Id and X,Y co-ordinate (position).** Attributes are:

id = Node Id  
locX = X coordinate  
locY = Y coordinate

Example:

```
<node id = "8" locX = "107.599" locY = "96.9366" />
```

4. <link> element

**This element describes wired links between two nodes.** Attributes are:

```

fromId = From Node Id (first node id)
toId   = To Node Id (second node id)

```

Example:

```
<link fromId="0" toId="1"/>
```

#### 5. <packet> element

This element describes a packet over wired links being transmitted at some node and received at another.

**The reception details are described in its associated rx element** Attributes are:

```

fromId = Node Id transmitting the packet
fbTx   = First bit transmit time of the packet
lbTx   = Last bit transmit time of the packet

```

Example:

```
<packet fromId="1" fbTx="1" lbTx="1.000067199"><rx toLp="0" toId="0" fbRx="1.002" lbRx="1.002067199">
```

A packet over wired-links from Node 1 was received at Node 0. The first bit of the packet was transmitted at the 1st second, the last bit was transmitted at the 1.000067199th second of the simulation Node 0 received the first bit of the packet at the 1.002th second and the last bit of the packet at the 1.002067199th second of the simulation NOTE: A packet with fromId == toId is a dummy packet used internally by the AnimationInterface. Please ignore this packet

#### 6. <rx> element

**This element describes the reception of a packet at a node.** Attributes are:

```

toId   = Node Id receiving the packet
fbRx   = First bit Reception Time of the packet
lbRx   = Last bit Reception Time of the packet

```

#### 7. <wpacket> element

This element describes a packet over wireless links being transmitted at some node and received at another.

**The reception details are described in its associated rx element.** Attributes are:

```

fromId = Node Id transmitting the packet
fbTx   = First bit transmit time of the packet
lbTx   = Last bit transmit time of the packet
range  = Range of the transmission

```

Example:

```
<wpacket fromId = "20" fbTx = "0.003" lbTx = "0.003254" range = "59.68176982">
<rx toLp="0" toId="32" fbRx="0.003000198" lbRx="0.003254198"/>
```

A packet over wireless-links from Node 20 was received at Node 32. The first bit of the packet was transmitted at the 0.003th second, the last bit was transmitted at the 0.003254 second of the simulation Node 0 received the first bit of the packet at the 0.003000198 second and the last bit of the packet at the 0.003254198 second of the simulation

## 2.1.7 Wiki

For detailed instructions on installing “NetAnim”, F.A.Qs and loading the XML trace file (mentioned earlier) using NetAnim please refer: <http://www.nsnam.org/wiki/index.php/NetAnim>



# ANTENNA MODULE

## 3.1 Design documentation

### 3.1.1 Overview

The Antenna module provides:

1. a new base class (`AntennaModel`) that provides an interface for the modeling of the radiation pattern of an antenna;
2. a set of classes derived from this base class that each models the radiation pattern of different types of antennas.

### 3.1.2 `AntennaModel`

The `AntennaModel` uses the coordinate system adopted in [Balanis] and depicted in Figure *Coordinate system of the AntennaModel*. This system is obtained by translating the cartesian coordinate system used by the ns-3 `MobilityModel` into the new origin  $o$  which is the location of the antenna, and then transforming the coordinates of every generic point  $p$  of the space from cartesian coordinates  $(x, y, z)$  into spherical coordinates  $(r, \theta, \phi)$ . The antenna model neglects the radial component  $r$ , and only considers the angle components  $(\theta, \phi)$ . An antenna radiation pattern is then expressed as a mathematical function  $g(\theta, \phi) \rightarrow \mathcal{R}$  that returns the gain (in dB) for each possible direction of transmission/reception. All angles are expressed in radians.

### 3.1.3 Provided models

In this section we describe the antenna radiation pattern models that are included within the antenna module.

#### `IsotropicAntennaModel`

This antenna radiation pattern model provides a unitary gain (0 dB) for all direction.

#### `CosineAntennaModel`

This is the cosine model described in [Chunjian]: the antenna gain is determined as:

$$g(\phi, \theta) = \cos^n \left( \frac{\phi - \phi_0}{2} \right)$$

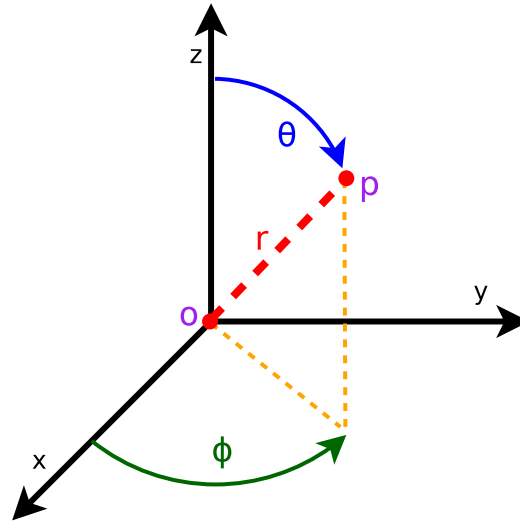

Figure 3.1: Coordinate system of the AntennaModel

where  $\phi_0$  is the azimuthal orientation of the antenna (i.e., its direction of maximum gain) and the exponential

$$n = -\frac{3}{20 \log_{10} \left( \cos \frac{\phi_{3dB}}{4} \right)}$$

determines the desired 3dB beamwidth  $\phi_{3dB}$ .

A major difference between the model of [Chunjian] and the one implemented in the class CosineAntennaModel is that only the element factor (i.e., what described by the above formulas) is considered. In fact, [Chunjian] also considered an additional antenna array factor. The reason why the latter is excluded is that we expect that the average user would desire to specify a given beamwidth exactly, without adding an array factor at a latter stage which would in practice alter the effective beamwidth of the resulting radiation pattern.

### ParabolicAntennaModel

This model is based on the parabolic approximation of the main lobe radiation pattern. It is often used in the context of cellular system to model the radiation pattern of a cell sector, see for instance [R4-092042a] and [Calcev]. The antenna gain in dB is determined as:

$$g_{dB}(\phi, \theta) = -\min \left( 12 \left( \frac{\phi - \phi_0}{\phi_{3dB}} \right)^2, A_{max} \right)$$

where  $\phi_0$  is the azimuthal orientation of the antenna (i.e., its direction of maximum gain),  $\phi_{3dB}$  is its 3 dB beamwidth, and  $A_{max}$  is the maximum attenuation in dB of the antenna.

## 3.2 User Documentation

The antenna module can be used with all the wireless technologies and physical layer models that support it. Currently, this includes the physical layer models based on the SpectrumPhy. Please refer to the documentation of each of these models for details.



## 3.3 Testing Documentation

In this section we describe the test suites included with the antenna module that verify its correct functionality.

### 3.3.1 Angles

The unit test suite `angles` verifies that the `Angles` class is constructed properly by correct conversion from 3D cartesian coordinates according to the available methods (construction from a single vector and from a pair of vectors). For each method, several test cases are provided that compare the values  $(\phi, \theta)$  determined by the constructor to known reference values. The test passes if for each case the values are equal to the reference up to a tolerance of  $10^{-10}$  which accounts for numerical errors.

### 3.3.2 DegreesToRadians

The unit test suite `degrees-radians` verifies that the methods `DegreesToRadians` and `RadiansToDegrees` work properly by comparing with known reference values in a number of test cases. Each test case passes if the comparison is equal up to a tolerance of  $10^{-10}$  which accounts for numerical errors.

### 3.3.3 IsotropicAntennaModel

The unit test suite `isotropic-antenna-model` checks that the `IsotropicAntennaModel` class works properly, i.e., returns always a 0dB gain regardless of the direction.

### 3.3.4 CosineAntennaModel

The unit test suite `cosine-antenna-model` checks that the `CosineAntennaModel` class works properly. Several test cases are provided that check for the antenna gain value calculated at different directions and for different values of the orientation, the reference gain and the beamwidth. The reference gain is calculated by hand. Each test case passes if the reference gain in dB is equal to the value returned by `CosineAntennaModel` within a tolerance of 0.001, which accounts for the approximation done for the calculation of the reference values.

### 3.3.5 ParabolicAntennaModel

The unit test suite `parabolic-antenna-model` checks that the `ParabolicAntennaModel` class works properly. Several test cases are provided that check for the antenna gain value calculated at different directions and for different values of the orientation, the maximum attenuation and the beamwidth. The reference gain is calculated by hand. Each test case passes if the reference gain in dB is equal to the value returned by `ParabolicAntennaModel` within a tolerance of 0.001, which accounts for the approximation done for the calculation of the reference values.



# AD HOC ON-DEMAND DISTANCE VECTOR (AODV)

This model implements the base specification of the Ad Hoc On-Demand Distance Vector (AODV) protocol. The implementation is based on [\[rfc3561\]](#).

The model was written by Elena Buchatskaia and Pavel Boyko of ITTP RAS, and is based on the ns-2 AODV model developed by the CMU/MONARCH group and optimized and tuned by Samir Das and Mahesh Marina, University of Cincinnati, and also on the AODV-UU implementation by Erik Nordström of Uppsala University.

## 4.1 Model Description

The source code for the AODV model lives in the directory *src/aodv*.

### 4.1.1 Design

Class `ns3::aodv::RoutingProtocol` implements all functionality of service packet exchange and inherits from `ns3::Ipv4RoutingProtocol`. The base class defines two virtual functions for packet routing and forwarding. The first one, `ns3::aodv::RouteOutput`, is used for locally originated packets, and the second one, `ns3::aodv::RouteInput`, is used for forwarding and/or delivering received packets.

Protocol operation depends on many adjustable parameters. Parameters for this functionality are attributes of `ns3::aodv::RoutingProtocol`. Parameter default values are drawn from the RFC and allow the enabling/disabling protocol features, such as broadcasting HELLO messages, broadcasting data packets and so on.

AODV discovers routes on demand. Therefore, the AODV model buffers all packets while a route request packet (RREQ) is disseminated. A packet queue is implemented in `aodv-queue.cc`. A smart pointer to the packet, `ns3::Ipv4RoutingProtocol::ErrorCallback`, `ns3::Ipv4RoutingProtocol::UnicastForwardCallback`, and the IP header are stored in this queue. The packet queue implements garbage collection of old packets and a queue size limit.

The routing table implementation supports garbage collection of old entries and state machine, defined in the standard. It is implemented as a STL map container. The key is a destination IP address.

Some elements of protocol operation aren't described in the RFC. These elements generally concern cooperation of different OSI model layers. The model uses the following heuristics:

- This AODV implementation can detect the presence of unidirectional links and avoid them if necessary. If the node the model receives an RREQ for is a neighbor, the cause may be a unidirectional link. This heuristic is taken from AODV-UU implementation and can be disabled.

- Protocol operation strongly depends on broken link detection mechanism. The model implements two such heuristics. First, this implementation support HELLO messages. However HELLO messages are not a good way to perform neighbor sensing in a wireless environment (at least not over 802.11). Therefore, one may experience bad performance when running over wireless. There are several reasons for this: 1) HELLO messages are broadcasted. In 802.11, broadcasting is often done at a lower bit rate than unicasting, thus HELLO messages can travel further than unicast data. 2) HELLO messages are small, thus less prone to bit errors than data transmissions, and 3) Broadcast transmissions are not guaranteed to be bidirectional, unlike unicast transmissions. Second, we use layer 2 feedback when possible. Link are considered to be broken if frame transmission results in a transmission failure for all retries. This mechanism is meant for active links and works faster than the first method.

The layer 2 feedback implementation relies on the `TxErrHeader` trace source, currently supported in `AdhocWifiMac` only.

### 4.1.2 Scope and Limitations

The model is for IPv4 only. The following optional protocol optimizations are not implemented:

1. Expanding ring search.
2. Local link repair.
3. RREP, RREQ and HELLO message extensions.

These techniques require direct access to IP header, which contradicts the assertion from the AODV RFC that AODV works over UDP. This model uses UDP for simplicity, hindering the ability to implement certain protocol optimizations. The model doesn't use low layer raw sockets because they are not portable.

### 4.1.3 Future Work

No announced plans.

#### **4.1.4 References**

### **4.2 Usage**

#### **4.2.1 Examples**

#### **4.2.2 Helpers**

#### **4.2.3 Attributes**

#### **4.2.4 Tracing**

#### **4.2.5 Logging**

#### **4.2.6 Caveats**

### **4.3 Validation**

#### **4.3.1 Unit tests**

#### **4.3.2 Larger-scale performance tests**



# APPLICATIONS

*Placeholder chapter*





# BRIDGE NETDEVICE

*Placeholder chapter*

Some examples of the use of Bridge NetDevice can be found in `examples/csma/` directory.



# BUILDINGS MODULE

```
cd .. include:: replace.txt
```

## 7.1 Design documentation

### 7.1.1 Overview

The Buildings module provides:

1. a new class (`Building`) that models the presence of a building in a simulation scenario;
2. a new mobility model (`BuildingsMobilityModel`) that allows to specify the location, size and characteristics of buildings present in the simulated area, and allows the placement of nodes inside those buildings;
3. a container class with the definition of the most useful pathloss models and the correspondent variables called `BuildingsPropagationLossModel`.
4. a new propagation model (`HybridBuildingsPropagationLossModel`) working with the mobility model just introduced, that allows to model the phenomenon of indoor/outdoor propagation in the presence of buildings.
5. a simplified model working only with Okumura Hata (`OhBuildingsPropagationLossModel`) considering the phenomenon of indoor/outdoor propagation in the presence of buildings.

The models have been designed with LTE in mind, though their implementation is in fact independent from any LTE-specific code, and can be used with other ns-3 wireless technologies as well (e.g., wifi, wimax).

The `HybridBuildingsPropagationLossModel` pathloss model included is obtained through a combination of several well known pathloss models in order to mimic different environmental scenarios such as urban, suburban and open areas. Moreover, the model considers both outdoor and indoor indoor and outdoor communication has to be included since HeNB might be installed either within building and either outside. In case of indoor communication, the model has to consider also the type of building in outdoor <-> indoor communication according to some general criteria such as the wall penetration losses of the common materials; moreover it includes some general configuration for the internal walls in indoor communications.

The `OhBuildingsPropagationLossModel` pathloss model has been created for simplifying the previous one removing the thresholds for switching from one model to other. For doing this it has been used only one propagation model from the one available (i.e., the Okumura Hata). The presence of building is still considered in the model; therefore all the considerations of above regarding the building type are still valid. The same consideration can be done for what concern the environmental scenario and frequency since both of them are parameters of the model considered.

## 7.1.2 The Building class

The model includes a specific class called `Building` which contains a ns3 `Box` class for defining the dimension of the building. In order to implements the characteristics of the pathloss models included, the `Building` class supports the following attributes:

- building type:
  - Residential (default value)
  - Office
  - Commercial
- external walls type
  - Wood
  - `ConcreteWithWindows` (default value)
  - `ConcreteWithoutWindows`
  - `StoneBlocks`
- number of floors (default value 1, which means only ground-floor)
- number of rooms in x-axis (default value 1)
- number of rooms in y-axis (default value 1)

The `Building` class is based on the following assumptions:

- a buildings is represented as a rectangular parallelepiped (i.e., a box)
- the walls are parallel to the x, y, and z axis
- a building is divided into a grid of rooms, identified by the following parameters:
  - number of floors
  - number of rooms along the x-axis
  - number of rooms along the y-axis
- the z axis is the vertical axis, i.e., floor numbers increase for increasing z axis values
- the x and y room indices start from 1 and increase along the x and y axis respectively
- all rooms in a building have equal size

## 7.1.3 The BuildingsMobilityModel class

The `BuildingsMobilityModel` class, which inherits from the ns3 class `MobilityModel`, is in charge of managing the standard mobility functionalities plus providing information about the position of a node with respect to building. The information managed by `BuildingsMobilityModel` is:

- whether the node is indoor or outdoor
- if indoor:
  - in which building the node is
  - in which room the node is positioned (x, y and floor room indices)

The class `BuildingsMobilityModel` is used by `BuildingsPropagationLossModel` class, which inherits from the ns3 class `PropagationLossModel` and manages the pathloss computation of the single components and their composition according to the nodes' positions. Moreover, it implements also the shadowing, that is the loss due to obstacles in the main path (i.e., vegetation, buildings, etc.).

### 7.1.4 ItuR1238PropagationLossModel

This class implements a building-dependent indoor propagation loss model based on the ITU P.1238 model, which includes losses due to type of building (i.e., residential, office and commercial). The analytical expression is given in the following.

$$L_{\text{total}} = 20 \log f + N \log d + L_f(n) - 28[\text{dB}]$$

where:

$$N = \begin{cases} 28 & \text{residential} \\ 30 & \text{office} \\ 22 & \text{commercial} \end{cases} : \text{power loss coefficient [dB]}$$

$$L_f = \begin{cases} 4n & \text{residential} \\ 15 + 4(n - 1) & \text{office} \\ 6 + 3(n - 1) & \text{commercial} \end{cases}$$

$n$  : number of floors between base station and mobile ( $n \geq 1$ )

$f$  : frequency [MHz]

$d$  : distance (where  $d > 1$ ) [m]

### 7.1.5 BuildingsPropagationLossModel

The `BuildingsPropagationLossModel` provides an additional set of building-dependent pathloss model elements that are used to implement different pathloss logics. These pathloss model elements are described in the following subsections.

#### External Wall Loss (EWL)

This component models the penetration loss through walls for indoor to outdoor communications and vice-versa. The values are taken from the `[cost231]` model.

- Wood ~ 4 dB
- Concrete with windows (not metallized) ~ 7 dB
- Concrete without windows ~ 15 dB (spans between 10 and 20 in COST231)
- Stone blocks ~ 12 dB

#### Internal Walls Loss (IWL)

This component models the penetration loss occurring in indoor-to-indoor communications within the same building. The total loss is calculated assuming that each single internal wall has a constant penetration loss  $L_{siw}$ , and approximating the number of walls that are penetrated with the manhattan distance (in number of rooms) between the transmitter and the receiver. In detail, let  $x_1, y_1, x_2, y_2$  denote the room number along the  $x$  and  $y$  axis respectively for user 1 and 2; the total loss  $L_{IWL}$  is calculated as

$$L_{IWL} = L_{siw}(|x_1 - x_2| + |y_1 - y_2|)$$

## Height Gain Model (HG)

This component model the gain due to the fact that the transmitting device is on a floor above the ground. In the literature [turkmani] this gain has been evaluated as about 2 dB per floor. This gain can be applied to all the indoor to outdoor communications and vice-versa.

## Shadowing Model

The shadowing is modeled according to a log-normal distribution with variable standard deviation as function of the connection characteristics. In the implementation we considered three main possible scenarios which correspond to three standard deviations (i.e., the mean is always 0), in detail:

- outdoor (`m_shadowingSigmaOutdoor`, default value of 7 dB)  $\rightarrow X_O \sim N(\mu_O, \sigma_O^2)$ .
- indoor (`m_shadowingSigmaIndoor`, default value of 10 dB)  $\rightarrow X_I \sim N(\mu_I, \sigma_I^2)$ .
- external walls penetration (`m_shadowingSigmaExtWalls`, default value 5 dB)  $\rightarrow X_W \sim N(\mu_W, \sigma_W^2)$

The simulator generates a shadowing value per each active link according to nodes' position the first time the link is used for transmitting. In case of transmissions from outdoor nodes to indoor ones, and vice-versa, the standard deviation ( $\sigma_{IO}$ ) has to be calculated as the square root of the sum of the quadratic values of the standard deviation in case of outdoor nodes and the one for the external walls penetration. This is due to the fact that the components producing the shadowing are independent of each other; therefore, the variance of a distribution resulting from the sum of two independent normal ones is the sum of the variances.

$$\begin{aligned} X &\sim N(\mu, \sigma^2) \text{ and } Y \sim N(\nu, \tau^2) \\ Z = X + Y &\sim Z(\mu + \nu, \sigma^2 + \tau^2) \\ \Rightarrow \sigma_{IO} &= \sqrt{\sigma_O^2 + \sigma_W^2} \end{aligned}$$

### 7.1.6 Pathloss logics

In the following we describe the different pathloss logic that are implemented by inheriting from `BuildingsPropagationLossModel`.

#### HybridBuildingsPropagationLossModel

The `HybridBuildingsPropagationLossModel` pathloss model included is obtained through a combination of several well known pathloss models in order to mimic different outdoor and indoor scenarios, as well as indoor-to-outdoor and outdoor-to-indoor scenarios. In detail, the class `HybridBuildingsPropagationLossModel` integrates the following pathloss models:

- `OkumuraHataPropagationLossModel` (OH) (at frequencies > 2.3 GHz substituted by `Kun2600MhzPropagationLossModel`)
- `ItuR1411LosPropagationLossModel` and `ItuR1411NlosOverRooftopPropagationLossModel` (I1411)
- `ItuR1238PropagationLossModel` (I1238)
- the pathloss elements of the `BuildingsPropagationLossModel` (EWL, HG, IWL)

The following pseudo-code illustrates how the different pathloss model elements described above are integrated in `HybridBuildingsPropagationLossModel`:

```

if (txNode is outdoor)
  then
    if (rxNode is outdoor)
      then
        if (distance > 1 km)
          then
            if (rxNode or txNode is below the rooftop)
              then
                L = I1411
              else
                L = OH
            else
                L = I1411
          else (rxNode is indoor)
            if (distance > 1 km)
              then
                if (rxNode or txNode is below the rooftop)
                  L = I1411 + EWL + HG
                else
                  L = OH + EWL + HG
              else
                L = I1411 + EWL + HG
            else (txNode is indoor)
              if (rxNode is indoor)
                then
                  if (same building)
                    then
                      L = I1238 + IWL
                    else
                      L = I1411 + 2*EWL
                  else (rxNode is outdoor)
                    if (distance > 1 km)
                      then
                        if (rxNode or txNode is below the rooftop)
                          then
                            L = I1411 + EWL + HG
                          else
                            L = OH + EWL + HG
                      else
                        L = I1411 + EWL

```

We note that, for the case of communication between two nodes below rooftop level with distance is greater than 1 km, we still consider the I1411 model, since OH is specifically designed for macro cells and therefore for antennas above the roof-top level.

For the ITU-R P.1411 model we consider both the LOS and NLoS versions. In particular, we consider the LoS propagation for distances that are shorter than a tunable threshold (`m_itu1411NlosThreshold`). In case on NLoS propagation, the over the roof-top model is taken in consideration for modeling both macro BS and SC. In case on NLoS several parameters scenario dependent have been included, such as average street width, orientation, etc. The values of such parameters have to be properly set according to the scenario implemented, the model does not calculate natively their values. In case any values is provided, the standard ones are used, apart for the height of the mobile and BS, which instead their integrity is tested directly in the code (i.e., they have to be greater than zero). In the following we give the expressions of the components of the model.

We also note that the use of different propagation models (OH, I1411, I1238 with their variants) in `HybridBuildingsPropagationLossModel` can result in discontinuities of the pathloss with respect to distance. A proper tuning of the attributes (especially the distance threshold attributes) can avoid these discontinuities. However, since the behavior of each model depends on several other parameters (frequency, node height, etc), there is no default value of these

thresholds that can avoid the discontinuities in all possible configurations. Hence, an appropriate tuning of these parameters is left to the user.

## OhBuildingsPropagationLossModel

The `OhBuildingsPropagationLossModel` class has been created as a simple means to solve the discontinuity problems of `HybridBuildingsPropagationLossModel` without doing scenario-specific parameter tuning. The solution is to use only one propagation loss model (i.e., Okumura Hata), while retaining the structure of the pathloss logic for the calculation of other path loss components (such as wall penetration losses). The result is a model that is free of discontinuities (except those due to walls), but that is less realistic overall for a generic scenario with buildings and outdoor/indoor users, e.g., because Okumura Hata is not suitable neither for indoor communications nor for outdoor communications below rooftop level.

In detail, the class `OhBuildingsPropagationLossModel` integrates the following pathloss models:

- `OkumuraHataPropagationLossModel` (OH)
- the pathloss elements of the `BuildingsPropagationLossModel` (EWL, HG, IWL)

The following pseudo-code illustrates how the different pathloss model elements described above are integrated in `OhBuildingsPropagationLossModel`:

```
if (txNode is outdoor)
  then
    if (rxNode is outdoor)
      then
        L = OH
      else (rxNode is indoor)
        L = OH + EWL
else (txNode is indoor)
  if (rxNode is indoor)
    then
      if (same building)
        then
          L = OH + IWL
        else
          L = OH + 2*EWL
    else (rxNode is outdoor)
      L = OH + EWL
```

We note that `OhBuildingsPropagationLossModel` is a significant simplification with respect to `HybridBuildingsPropagationLossModel`, due to the fact that OH is used always. While this gives a less accurate model in some scenarios (especially below rooftop and indoor), it effectively avoids the issue of pathloss discontinuities that affects `HybridBuildingsPropagationLossModel`.

## 7.2 User Documentation

### 7.2.1 Main configurable parameters

The `Building` class has the following configurable parameters:

- `building type`: Residential, Office and Commercial.
- `external walls type`: Wood, ConcreteWithWindows, ConcreteWithoutWindows and StoneBlocks.
- `building bounds`: a `Box` class with the building bounds.



- number of floors.
- number of rooms in x-axis and y-axis (rooms can be placed only in a grid way).

The `BuildingMobilityLossModel` parameter configurable with the ns3 attribute system is represented by the bound (string `Bounds`) of the simulation area by providing a `Box` class with the area bounds. Moreover, by means of its methods the following parameters can be configured:

- the number of floor the node is placed (default 0).
- the position in the rooms grid.

The `BuildingPropagationLossModel` class has the following configurable parameters configurable with the attribute system:

- `Frequency`: reference frequency (default 2160 MHz), note that by setting the frequency the wavelength is set accordingly automatically and viceversa).
- `Lambda`: the wavelength (0.139 meters, considering the above frequency).
- `ShadowSigmaOutdoor`: the standard deviation of the shadowing for outdoor nodes (default 7.0).
- `ShadowSigmaIndoor`: the standard deviation of the shadowing for indoor nodes (default 8.0).
- `ShadowSigmaExtWalls`: the standard deviation of the shadowing due to external walls penetration for outdoor to indoor communications (default 5.0).
- `RoofLevel`: the level of the rooftop of the building in meters (default 20 meters).
- `Los2NlosThr`: the value of distance of the switching point between line-of-sight and non-line-of-sight propagation model in meters (default 200 meters).
- `ITU1411DistanceThr`: the value of distance of the switching point between short range (ITU 1211) communications and long range (Okumura Hata) in meters (default 200 meters).
- `MinDistance`: the minimum distance in meters between two nodes for evaluating the pathloss (considered negligible before this threshold) (default 0.5 meters).
- `Environment`: the environment scenario among `Urban`, `SubUrban` and `OpenAreas` (default `Urban`).
- `CitySize`: the dimension of the city among `Small`, `Medium`, `Large` (default `Large`).

In order to use the hybrid mode, the class to be used is the `HybridBuildingMobilityLossModel`, which allows the selection of the proper pathloss model according to the pathloss logic presented in the design chapter. However, this solution has the problem that the pathloss model switching points might present discontinuities due to the different characteristics of the model. This implies that according to the specific scenario, the threshold used for switching have to be properly tuned. The simple `OhBuildingMobilityLossModel` overcome this problem by using only the Okumura Hata model and the wall penetration losses.

## 7.3 Testing Documentation

### 7.3.1 Overview

To test and validate the ns-3 Building Pathloss module, some test suites is provided which are integrated with the ns-3 test framework. To run them, you need to have configured the build of the simulator in this way:

```
./waf configure --enable-tests --enable-modules=buildings
./test.py
```

The above will run not only the test suites belonging to the buildings module, but also those belonging to all the other ns-3 modules on which the buildings module depends. See the ns-3 manual for generic information on the testing framework.

You can get a more detailed report in HTML format in this way:

```
./test.py -w results.html
```

After the above command has run, you can view the detailed result for each test by opening the file `results.html` with a web browser.

You can run each test suite separately using this command:

```
./test.py -s test-suite-name
```

For more details about `test.py` and the ns-3 testing framework, please refer to the ns-3 manual.

### 7.3.2 Description of the test suites

#### BuildingsHelper test

The test suite `buildings-helper` checks that the method `BuildingsHelper::MakeAllInstancesConsistent()` works properly, i.e., that the `BuildingsHelper` is successful in locating if nodes are outdoor or indoor, and if indoor that they are located in the correct building, room and floor. Several test cases are provided with different buildings (having different size, position, rooms and floors) and different node positions. The test passes if each every node is located correctly.

#### BuildingPositionAllocator test

The test suite `building-position-allocator` feature two test cases that check that respectively `RandomRoomPositionAllocator` and `SameRoomPositionAllocator` work properly. Each test cases involves a single 2x3x2 room building (total 12 rooms) at known coordinates and respectively 24 and 48 nodes. Both tests check that the number of nodes allocated in each room is the expected one and that the position of the nodes is also correct.

#### Buildings Pathloss tests

The test suite `buildings-pathloss-model` provides different unit tests that compare the expected results of the buildings pathloss module in specific scenarios with pre calculated values obtained offline with an Octave script (`test/reference/buildings-pathloss.m`). The tests are considered passed if the two values are equal up to a tolerance of 0.1, which is deemed appropriate for the typical usage of pathloss values (which are in dB).

In the following we detailed the scenarios considered, their selection has been done for covering the wide set of possible pathloss logic combinations. The pathloss logic results therefore implicitly tested.

#### Test #1 Okumura Hata

In this test we test the standard Okumura Hata model; therefore both eNB and UE are placed outside at a distance of 2000 m. The frequency used is the E-UTRA band #5, which correspond to 869 MHz (see table 5.5-1 of 36.101). The test includes also the validation of the areas extensions (i.e., urban, suburban and open-areas) and of the city size (small, medium and large).

**Test #2 COST231 Model**

This test is aimed at validating the COST231 model. The test is similar to the Okumura Hata one, except that the frequency used is the EUTRA band #1 (2140 MHz) and that the test can be performed only for large and small cities in urban scenarios due to model limitations.

**Test #3 2.6 GHz model**

This test validates the 2.6 GHz Kun model. The test is similar to Okumura Hata one except that the frequency is the EUTRA band #7 (2620 MHz) and the test can be performed only in urban scenario.

**Test #4 ITU1411 LoS model**

This test is aimed at validating the ITU1411 model in case of line of sight within street canyons transmissions. In this case the UE is placed at 100 meters far from the eNB, since the threshold for switching between LoS and NLoS is left to default one (i.e., 200 m.).

**Test #5 ITU1411 NLoS model**

This test is aimed at validating the ITU1411 model in case of non line of sight over the rooftop transmissions. In this case the UE is placed at 900 meters far from the eNB, in order to be above the threshold for switching between LoS and NLoS is left to default one (i.e., 200 m.).

**Test #6 ITUP1238 model**

This test is aimed at validating the ITUP1238 model in case of indoor transmissions. In this case both the UE and the eNB are placed in a residential building with walls made of concrete with windows. Ue is placed at the second floor and distances 30 meters far from the eNB, which is placed at the first floor.

**Test #7 Outdoor -> Indoor with Okumura Hata model**

This test validates the outdoor to indoor transmissions for large distances. In this case the UE is placed in a residential building with wall made of concrete with windows and distances 2000 meters from the outdoor eNB.

**Test #8 Outdoor -> Indoor with ITU1411 model**

This test validates the outdoor to indoor transmissions for short distances. In this case the UE is placed in a residential building with walls made of concrete with windows and distances 100 meters from the outdoor eNB.

**Test #9 Indoor -> Outdoor with ITU1411 model**

This test validates the outdoor to indoor transmissions for very short distances. In this case the eNB is placed in the second floor of a residential building with walls made of concrete with windows and distances 100 meters from the outdoor UE (i.e., LoS communication). Therefore the height gain has to be included in the pathloss evaluation.

### Test #10 Indoor -> Outdoor with ITU1411 model

This test validates the outdoor to indoor transmissions for short distances. In this case the eNB is placed in the second floor of a residential building with walls made of concrete with windows and distances 500 meters from the outdoor UE (i.e., NLoS communication). Therefore the height gain has to be included in the pathloss evaluation.

### Buildings Shadowing Test

The test suite `buildings-shadowing-test` is a unit test intended to verify the statistics distribution characteristics of the shadowing are the one expected. The shadowing is modeled according to a normal distribution with mean  $\mu = 0$  and variable standard deviation  $\sigma$ , according to models commonly used in literature. The test generates 10,000 samples of shadowing by subtracting the deterministic component from the total loss returned by the `BuildingPathlossModel`. The mean and variance of the shadowing samples are then used to verify whether the 99% confidence interval is respected by the sequence generated by the simulator.

## 7.4 References

# CLICK MODULAR ROUTER INTEGRATION

Click is a software architecture for building configurable routers. By using different combinations of packet processing units called elements, a Click router can be made to perform a specific kind of functionality. This flexibility provides a good platform for testing and experimenting with different protocols.

## 8.1 Model Description

The source code for the Click model lives in the directory `src/click`.

### 8.1.1 Design

ns-3's design is well suited for an integration with Click due to the following reasons:

- Packets in ns-3 are serialised/deserialised as they move up/down the stack. This allows ns-3 packets to be passed to and from Click as they are.
- This also means that any kind of ns-3 traffic generator and transport should work easily on top of Click.
- By striving to implement click as an `Ipv4RoutingProtocol` instance, we can avoid significant changes to the LL and MAC layer of the ns-3 code.

The design goal was to make the ns-3-click public API simple enough such that the user needs to merely add an `Ipv4ClickRouting` instance to the node, and inform each Click node of the Click configuration file (.click file) that it is to use.

This model implements the interface to the Click Modular Router and provides the `Ipv4ClickRouting` class to allow a node to use Click for external routing. Unlike normal `Ipv4RoutingProtocol` sub types, `Ipv4ClickRouting` doesn't use a `RouteInput()` method, but instead, receives a packet on the appropriate interface and processes it accordingly. Note that you need to have a routing table type element in your Click graph to use Click for external routing. This is needed by the `RouteOutput()` function inherited from `Ipv4RoutingProtocol`. Furthermore, a Click based node uses a different kind of L3 in the form of `Ipv4L3ClickProtocol`, which is a trimmed down version of `Ipv4L3Protocol`. `Ipv4L3ClickProtocol` passes on packets passing through the stack to `Ipv4ClickRouting` for processing.

### Developing a Simulator API to allow ns-3 to interact with Click

Much of the API is already well defined, which allows Click to probe for information from the simulator (like a Node's ID, an Interface ID and so forth). By retaining most of the methods, it should be possible to write new implementations specific to ns-3 for the same functionality.

Hence, for the Click integration with ns-3, a class named `Ipv4ClickRouting` will handle the interaction with Click. The code for the same can be found in `src/click/model/ipv4-click-routing.{cc,h}`.

### Packet hand off between ns-3 and Click

There are four kinds of packet hand-offs that can occur between ns-3 and Click.

- L4 to L3
- L3 to L4
- L3 to L2
- L2 to L3

To overcome this, we implement `Ipv4L3ClickProtocol`, a stripped down version of `Ipv4L3Protocol`. `Ipv4L3ClickProtocol` passes packets to and from `Ipv4ClickRouting` appropriately to perform routing.

### 8.1.2 Scope and Limitations

- In its current state, the NS-3 Click Integration is limited to use only with L3, leaving NS-3 to handle L2. We are currently working on adding Click MAC support as well. See the usage section to make sure that you design your Click graphs accordingly.
- Furthermore, ns-3-click will work only with userlevel elements. The complete list of elements are available at <http://read.cs.ucla.edu/click/elements>. Elements that have 'all', 'userlevel' or 'ns' mentioned beside them may be used.
- As of now, the ns-3 interface to Click is Ipv4 only. We will be adding Ipv6 support in the future.

### 8.1.3 References

- Eddie Kohler, Robert Morris, Benjie Chen, John Jannotti, and M. Frans Kaashoek. The click modular router. *ACM Transactions on Computer Systems* 18(3), August 2000, pages 263-297.
- Lalith Suresh P., and Ruben Merz. Ns-3-click: click modular router integration for ns-3. In *Proc. of 3rd International ICST Workshop on NS-3 (WNS3)*, Barcelona, Spain. March, 2011.
- Michael Neufeld, Ashish Jain, and Dirk Grunwald. Nsclick: bridging network simulation and deployment. *MSWiM '02: Proceedings of the 5th ACM international workshop on Modeling analysis and simulation of wireless and mobile systems*, 2002, Atlanta, Georgia, USA. <http://doi.acm.org/10.1145/570758.570772>

## 8.2 Usage

### 8.2.1 Building Click

The first step is to fetch (<http://read.cs.ucla.edu/click/download>) and build Click. At the top of your Click source directory:

```
$: ./configure --enable-userlevel --disable-linuxmodule --enable-nsclick --enable-wifi
$: make
```

The `--enable-wifi` flag may be skipped if you don't intend on using Click with Wifi. \* Note: You don't need to do a 'make install'.

Once Click has been built successfully, change into the ns-3 directory and configure ns-3 with Click Integration support:

```
$: ./waf configure --enable-examples --enable-tests --with-nsclick=/path/to/click/source
```

Hint: If you have click installed one directory above ns-3 (such as in the ns-3-allinone directory), and the name of the directory is 'click' (or a symbolic link to the directory is named 'click'), then the `--with-nsclick` specifier is not necessary; the ns-3 build system will successfully find the directory.

If it says 'enabled' beside 'NS-3 Click Integration Support', then you're good to go. Note: If running modular ns-3, the minimum set of modules required to run all ns-3-click examples is wifi, csma and config-store.

Next, try running one of the examples:

```
$: ./waf --run nsclick-simple-lan
```

You may then view the resulting .pcap traces, which are named nsclick-simple-lan-0-0.pcap and nsclick-simple-lan-0-1.pcap.

## 8.2.2 Click Graph Instructions

The following should be kept in mind when making your Click graph:

- Only userlevel elements can be used.
- You will need to replace FromDevice and ToDevice elements with FromSimDevice and ToSimDevice elements.
- Packets to the kernel are sent up using ToSimDevice(tap0,IP).
- For any node, the device which sends/receives packets to/from the kernel, is named 'tap0'. The remaining interfaces should be named eth0, eth1 and so forth (even if you're using wifi). Please note that the device numbering should begin from 0. In future, this will be made flexible so that users can name devices in their Click file as they wish.
- A routing table element is a mandatory. The OUTports of the routing table element should correspond to the interface number of the device through which the packet will ultimately be sent out. Violating this rule will lead to really weird packet traces. This routing table element's name should then be passed to the Ipv4ClickRouting protocol object as a simulation parameter. See the Click examples for details.
- The current implementation leaves Click with mainly L3 functionality, with ns-3 handling L2. We will soon begin working to support the use of MAC protocols on Click as well. This means that as of now, Click's Wifi specific elements cannot be used with ns-3.

## 8.2.3 Debugging Packet Flows from Click

From any point within a Click graph, you may use the Print (<http://read.cs.ucla.edu/click/elements/print>) element and its variants for pretty printing of packet contents. Furthermore, you may generate pcap traces of packets flowing through a Click graph by using the ToDump (<http://read.cs.ucla.edu/click/elements/todump>) element as well. For instance:

```
myarpquerier
-> Print(fromarpquery,64)
-> ToDump(out_arpquery,PER_NODE 1)
-> ethout;
```

and ...will print the contents of packets that flow out of the `ArpQuerier`, then generate a pcap trace file which will have a suffix `'out_arpquery'`, for each node using the Click file, before pushing packets onto `'ethout'`.

## 8.2.4 Helper

To have a node run Click, the easiest way would be to use the `ClickInternetStackHelper` class in your simulation script. For instance:

```
ClickInternetStackHelper click;
click.SetClickFile (myNodeContainer, "nsclick-simple-lan.click");
click.SetRoutingTableElement (myNodeContainer, "u/rt");
click.Install (myNodeContainer);
```

The example scripts inside `src/click/examples/` demonstrate the use of Click based nodes in different scenarios. The helper source can be found inside `src/click/helper/click-internet-stack-helper.{h,cc}`

## 8.2.5 Examples

The following examples have been written, which can be found in `src/click/examples/`:

- `nsclick-simple-lan.cc` and `nsclick-raw-wlan.cc`: A Click based node communicating with a normal ns-3 node without Click, using `Csma` and `Wifi` respectively. It also demonstrates the use of `TCP` on top of Click, something which the original `nsclick` implementation for NS-2 couldn't achieve.
- `nsclick-udp-client-server-csma.cc` and `nsclick-udp-client-server-wifi.cc`: A 3 node LAN (`Csma` and `Wifi` respectively) wherein 2 Click based nodes run a `UDP` client, that sends packets to a third Click based node running a `UDP` server.
- `nsclick-routing.cc`: One Click based node communicates to another via a third node that acts as an IP router (using the IP router Click configuration). This demonstrates routing using Click.

Scripts are available within `<click-dir>/conf/` that allow you to generate Click files for some common scenarios. The IP Router used in `nsclick-routing.cc` was generated from the `make-ip-conf.pl` file and slightly adapted to work with `ns-3-click`.

## 8.3 Validation

This model has been tested as follows:

- Unit tests have been written to verify the internals of `Ipv4ClickRouting`. This can be found in `src/click/ipv4-click-routing-test.cc`. These tests verify whether the methods inside `Ipv4ClickRouting` which deal with Device name to ID, IP Address from device name and Mac Address from device name bindings work as expected.
- The examples have been used to test Click with actual simulation scenarios. These can be found in `src/click/examples/`. These tests cover the following: the use of different kinds of transports on top of Click, `TCP/UDP`, whether Click nodes can communicate with non-Click based nodes, whether Click nodes can communicate with each other, using Click to route packets using static routing.
- Click has been tested with `Csma`, `Wifi` and `Point-to-Point` devices. Usage instructions are available in the preceding section.



# CSMA NETDEVICE

This is the introduction to CSMA NetDevice chapter, to complement the Csma model doxygen.

## 9.1 Overview of the CSMA model

The *ns-3* CSMA device models a simple bus network in the spirit of Ethernet. Although it does not model any real physical network you could ever build or buy, it does provide some very useful functionality.

Typically when one thinks of a bus network Ethernet or IEEE 802.3 comes to mind. Ethernet uses CSMA/CD (Carrier Sense Multiple Access with Collision Detection with exponentially increasing backoff to contend for the shared transmission medium. The *ns-3* CSMA device models only a portion of this process, using the nature of the globally available channel to provide instantaneous (faster than light) carrier sense and priority-based collision “avoidance.” Collisions in the sense of Ethernet never happen and so the *ns-3* CSMA device does not model collision detection, nor will any transmission in progress be “jammed.”

### 9.1.1 CSMA Layer Model

There are a number of conventions in use for describing layered communications architectures in the literature and in textbooks. The most common layering model is the ISO seven layer reference model. In this view the *CsmaNetDevice* and *CsmaChannel* pair occupies the lowest two layers – at the physical (layer one), and data link (layer two) positions. Another important reference model is that specified by RFC 1122, “Requirements for Internet Hosts – Communication Layers.” In this view the *CsmaNetDevice* and *CsmaChannel* pair occupies the lowest layer – the link layer. There is also a seemingly endless litany of alternative descriptions found in textbooks and in the literature. We adopt the naming conventions used in the IEEE 802 standards which speak of LLC, MAC, MII and PHY layering. These acronyms are defined as:

- LLC: Logical Link Control;
- MAC: Media Access Control;
- MII: Media Independent Interface;
- PHY: Physical Layer.

In this case the *LLC* and *MAC* are sublayers of the OSI data link layer and the *MI*I and *PHY* are sublayers of the OSI physical layer.

The “top” of the CSMA device defines the transition from the network layer to the data link layer. This transition is performed by higher layers by calling either *CsmaNetDevice::Send* or *CsmaNetDevice::SendFrom*.

In contrast to the IEEE 802.3 standards, there is no precisely specified PHY in the CSMA model in the sense of wire types, signals or pinouts. The “bottom” interface of the *CsmaNetDevice* can be thought of as as a kind of Media

Independent Interface (MII) as seen in the “Fast Ethernet” (IEEE 802.3u) specifications. This MII interface fits into a corresponding media independent interface on the `CsmaChannel`. You will not find the equivalent of a 10BASE-T or a 1000BASE-LX PHY.

The `CsmaNetDevice` calls the `CsmaChannel` through a media independent interface. There is a method defined to tell the channel when to start “wiggling the wires” using the method `CsmaChannel::TransmitStart`, and a method to tell the channel when the transmission process is done and the channel should begin propagating the last bit across the “wire”: `CsmaChannel::TransmitEnd`.

When the `TransmitEnd` method is executed, the channel will model a single uniform signal propagation delay in the medium and deliver copies of the packet to each of the devices attached to the packet via the `CsmaNetDevice::Receive` method.

There is a “pin” in the device media independent interface corresponding to “COL” (collision). The state of the channel may be sensed by calling `CsmaChannel::GetState`. Each device will look at this “pin” before starting a send and will perform appropriate backoff operations if required.

Properly received packets are forwarded up to higher levels from the `CsmaNetDevice` via a callback mechanism. The callback function is initialized by the higher layer (when the net device is attached) using `CsmaNetDevice::SetReceiveCallback` and is invoked upon “proper” reception of a packet by the net device in order to forward the packet up the protocol stack.

## 9.2 CSMA Channel Model

The class `CsmaChannel` models the actual transmission medium. There is no fixed limit for the number of devices connected to the channel. The `CsmaChannel` models a data rate and a speed-of-light delay which can be accessed via the attributes “DataRate” and “Delay” respectively. The data rate provided to the channel is used to set the data rates used by the transmitter sections of the CSMA devices connected to the channel. There is no way to independently set data rates in the devices. Since the data rate is only used to calculate a delay time, there is no limitation (other than by the data type holding the value) on the speed at which CSMA channels and devices can operate; and no restriction based on any kind of PHY characteristics.

The `CsmaChannel` has three states, `IDLE`, `TRANSMITTING` and `PROPAGATING`. These three states are “seen” instantaneously by all devices on the channel. By this we mean that if one device begins or ends a simulated transmission, all devices on the channel are *immediately* aware of the change in state. There is no time during which one device may see an `IDLE` channel while another device physically further away in the collision domain may have begun transmitting with the associated signals not propagated down the channel to other devices. Thus there is no need for collision detection in the `CsmaChannel` model and it is not implemented in any way.

We do, as the name indicates, have a Carrier Sense aspect to the model. Since the simulator is single threaded, access to the common channel will be serialized by the simulator. This provides a deterministic mechanism for contending for the channel. The channel is allocated (transitioned from state `IDLE` to state `TRANSMITTING`) on a first-come first-served basis. The channel always goes through a three state process::

```
IDLE -> TRANSMITTING -> PROPAGATING -> IDLE
```

The `TRANSMITTING` state models the time during which the source net device is actually wiggling the signals on the wire. The `PROPAGATING` state models the time after the last bit was sent, when the signal is propagating down the wire to the “far end.”

The transition to the `TRANSMITTING` state is driven by a call to `CsmaChannel::TransmitStart` which is called by the net device that transmits the packet. It is the responsibility of that device to end the transmission with a call to `CsmaChannel::TransmitEnd` at the appropriate simulation time that reflects the time elapsed to put all of the packet bits on the wire. When `TransmitEnd` is called, the channel schedules an event corresponding to a single speed-of-light delay. This delay applies to all net devices on the channel identically. You can think of a symmetrical hub in which the packet bits propagate to a central location and then back out equal length cables to the other devices on the

channel. The single “speed of light” delay then corresponds to the time it takes for: 1) a signal to propagate from one `CsmaNetDevice` through its cable to the hub; plus 2) the time it takes for the hub to forward the packet out a port; plus 3) the time it takes for the signal in question to propagate to the destination net device.

The `CsmaChannel` models a broadcast medium so the packet is delivered to all of the devices on the channel (including the source) at the end of the propagation time. It is the responsibility of the sending device to determine whether or not it receives a packet broadcast over the channel.

The `CsmaChannel` provides following Attributes:

- `DataRate`: The bitrate for packet transmission on connected devices;
- `Delay`: The speed of light transmission delay for the channel.

## 9.3 CSMA Net Device Model

The CSMA network device appears somewhat like an Ethernet device. The `CsmaNetDevice` provides following Attributes:

- `Address`: The `Mac48Address` of the device;
- `SendEnable`: Enable packet transmission if true;
- `ReceiveEnable`: Enable packet reception if true;
- `EncapsulationMode`: Type of link layer encapsulation to use;
- `RxErrorModel`: The receive error model;
- `TxQueue`: The transmit queue used by the device;
- `InterframeGap`: The optional time to wait between “frames”;
- `Rx`: A trace source for received packets;
- `Drop`: A trace source for dropped packets.

The `CsmaNetDevice` supports the assignment of a “receive error model.” This is an `ErrorModel` object that is used to simulate data corruption on the link.

Packets sent over the `CsmaNetDevice` are always routed through the transmit queue to provide a trace hook for packets sent out over the network. This transmit queue can be set (via attribute) to model different queuing strategies.

Also configurable by attribute is the encapsulation method used by the device. Every packet gets an `EthernetHeader` that includes the destination and source MAC addresses, and a length/type field. Every packet also gets an `EthernetTrailer` which includes the FCS. Data in the packet may be encapsulated in different ways.

By default, or by setting the “`EncapsulationMode`” attribute to “`Dix`”, the encapsulation is according to the DEC, Intel, Xerox standard. This is sometimes called EthernetII framing and is the familiar destination MAC, source MAC, EtherType, Data, CRC format.

If the “`EncapsulationMode`” attribute is set to “`Llc`”, the encapsulation is by LLC SNAP. In this case, a SNAP header is added that contains the EtherType (IP or ARP).

The other implemented encapsulation modes are `IP_ARP` (set “`EncapsulationMode`” to “`IpArp`”) in which the length type of the Ethernet header receives the protocol number of the packet; or `ETHERNET_V1` (set “`EncapsulationMode`” to “`EthernetV1`”) in which the length type of the Ethernet header receives the length of the packet. A “`Raw`” encapsulation mode is defined but not implemented – use of the RAW mode results in an assertion.

Note that all net devices on a channel must be set to the same encapsulation mode for correct results. The encapsulation mode is not sensed at the receiver.

The `CsmaNetDevice` implements a random exponential backoff algorithm that is executed if the channel is determined to be busy (`TRANSMITTING` or `PPROPAGATING`) when the device wants to start propagating. This results in a random delay of up to  $2^{\text{retries}} - 1$  microseconds before a retry is attempted. The default maximum number of retries is 1000.

## 9.4 Using the `CsmaNetDevice`

The CSMA net devices and channels are typically created and configured using the associated `CsmaHelper` object. The various *ns-3* device helpers generally work in a similar way, and their use is seen in many of our example programs.

The conceptual model of interest is that of a bare computer “husk” into which you plug net devices. The bare computers are created using a `NodeContainer` helper. You just ask this helper to create as many computers (we call them `Nodes`) as you need on your network::

```
NodeContainer csmaNodes;  
csmaNodes.Create (nCsmasNodes);
```

Once you have your nodes, you need to instantiate a `CsmaHelper` and set any attributes you may want to change.:

```
CsmaHelper csma;  
csma.SetChannelAttribute ("DataRate", StringValue ("100Mbps"));  
csma.SetChannelAttribute ("Delay", TimeValue (NanoSeconds (6560)));  
  
csma.SetDeviceAttribute ("EncapsulationMode", StringValue ("Dix"));  
csma.SetDeviceAttribute ("FrameSize", UIntegerValue (2000));
```

Once the attributes are set, all that remains is to create the devices and install them on the required nodes, and to connect the devices together using a CSMA channel. When we create the net devices, we add them to a container to allow you to use them in the future. This all takes just one line of code.:

```
NetDeviceContainer csmaDevices = csma.Install (csmaNodes);
```

We recommend thinking carefully about changing these Attributes, since it can result in behavior that surprises users. We allow this because we believe flexibility is important. As an example of a possibly surprising effect of changing Attributes, consider the following:

The `Mtu` Attribute indicates the Maximum Transmission Unit to the device. This is the size of the largest Protocol Data Unit (PDU) that the device can send. This Attribute defaults to 1500 bytes and corresponds to a number found in RFC 894, “A Standard for the Transmission of IP Datagrams over Ethernet Networks.” The number is actually derived from the maximum packet size for 10Base5 (full-spec Ethernet) networks – 1518 bytes. If you subtract DIX encapsulation overhead for Ethernet packets (18 bytes) you will end up with a maximum possible data size (MTU) of 1500 bytes. One can also find that the MTU for IEEE 802.3 networks is 1492 bytes. This is because LLC/SNAP encapsulation adds an extra eight bytes of overhead to the packet. In both cases, the underlying network hardware is limited to 1518 bytes, but the MTU is different because the encapsulation is different.

If one leaves the `Mtu` Attribute at 1500 bytes and changes the encapsulation mode Attribute to `Llc`, the result will be a network that encapsulates 1500 byte PDUs with LLC/SNAP framing resulting in packets of 1526 bytes. This would be illegal in many networks, but we allow you do do this. This results in a simulation that quite subtly does not reflect what you might be expecting since a real device would balk at sending a 1526 byte packet.

There also exist jumbo frames ( $1500 < \text{MTU} \leq 9000$  bytes) and super-jumbo ( $\text{MTU} > 9000$  bytes) frames that are not officially sanctioned by IEEE but are available in some high-speed (Gigabit) networks and NICs. In the CSMA model, one could leave the encapsulation mode set to `Dix`, and set the `Mtu` to 64000 bytes – even though an associated `CsmaChannel DataRate` was left at 10 megabits per second (certainly not Gigabit Ethernet). This would essentially model an Ethernet switch made out of vampire-tapped 1980s-style 10Base5 networks that support super-jumbo datagrams, which is certainly not something that was ever made, nor is likely to ever be made; however it is quite easy for you to configure.

Be careful about assumptions regarding what CSMA is actually modelling and how configuration (Attributes) may allow you to swerve considerably away from reality.

## 9.5 CSMA Tracing

Like all *ns-3* devices, the CSMA Model provides a number of trace sources. These trace sources can be hooked using your own custom trace code, or you can use our helper functions to arrange for tracing to be enabled on devices you specify.

### 9.5.1 Upper-Level (MAC) Hooks

From the point of view of tracing in the net device, there are several interesting points to insert trace hooks. A convention inherited from other simulators is that packets destined for transmission onto attached networks pass through a single “transmit queue” in the net device. We provide trace hooks at this point in packet flow, which corresponds (abstractly) only to a transition from the network to data link layer, and call them collectively the device MAC hooks.

When a packet is sent to the CSMA net device for transmission it always passes through the transmit queue. The transmit queue in the `CsmaNetDevice` inherits from `Queue`, and therefore inherits three trace sources:

- An Enqueue operation source (see `Queue::m_traceEnqueue`);
- A Dequeue operation source (see `Queue::m_traceDequeue`);
- A Drop operation source (see `Queue::m_traceDrop`).

The upper-level (MAC) trace hooks for the `CsmaNetDevice` are, in fact, exactly these three trace sources on the single transmit queue of the device.

The `m_traceEnqueue` event is triggered when a packet is placed on the transmit queue. This happens at the time that `CsmaNetDevice::Send` or `CsmaNetDevice::SendFrom` is called by a higher layer to queue a packet for transmission.

The `m_traceDequeue` event is triggered when a packet is removed from the transmit queue. Dequeues from the transmit queue can happen in three situations: 1) If the underlying channel is idle when the `CsmaNetDevice::Send` or `CsmaNetDevice::SendFrom` is called, a packet is dequeued from the transmit queue and immediately transmitted; 2) If the underlying channel is idle, a packet may be dequeued and immediately transmitted in an internal `TransmitCompleteEvent` that functions much like a transmit complete interrupt service routine; or 3) from the random exponential backoff handler if a timeout is detected.

Case (3) implies that a packet is dequeued from the transmit queue if it is unable to be transmitted according to the backoff rules. It is important to understand that this will appear as a Dequeued packet and it is easy to incorrectly assume that the packet was transmitted since it passed through the transmit queue. In fact, a packet is actually dropped by the net device in this case. The reason for this behavior is due to the definition of the `Queue Drop` event. The `m_traceDrop` event is, by definition, fired when a packet cannot be enqueued on the transmit queue because it is full. This event only fires if the queue is full and we do not overload this event to indicate that the `CsmaChannel` is “full.”

### 9.5.2 Lower-Level (PHY) Hooks

Similar to the upper level trace hooks, there are trace hooks available at the lower levels of the net device. We call these the PHY hooks. These events fire from the device methods that talk directly to the `CsmaChannel`.

The trace source `m_dropTrace` is called to indicate a packet that is dropped by the device. This happens in two cases: First, if the receive side of the net device is not enabled (see `CsmaNetDevice::m_receiveEnable` and the associated attribute “`ReceiveEnable`”).

The `m_dropTrace` is also used to indicate that a packet was discarded as corrupt if a receive error model is used (see `CsmaNetDevice::m_receiveErrorModel` and the associated attribute “`ReceiveErrorModel`”).

The other low-level trace source fires on reception of an accepted packet (see `CsmaNetDevice::m_rxTrace`). A packet is accepted if it is destined for the broadcast address, a multicast address, or to the MAC address assigned to the net device.

## 9.6 Summary

The ns3 CSMA model is a simplistic model of an Ethernet-like network. It supports a Carrier-Sense function and allows for Multiple Access to a shared medium. It is not physical in the sense that the state of the medium is instantaneously shared among all devices. This means that there is no collision detection required in this model and none is implemented. There will never be a “jam” of a packet already on the medium. Access to the shared channel is on a first-come first-served basis as determined by the simulator scheduler. If the channel is determined to be busy by looking at the global state, a random exponential backoff is performed and a retry is attempted.

Ns-3 Attributes provide a mechanism for setting various parameters in the device and channel such as addresses, encapsulation modes and error model selection. Trace hooks are provided in the usual manner with a set of upper level hooks corresponding to a transmit queue and used in ASCII tracing; and also a set of lower level hooks used in pcap tracing.

Although the ns-3 `CsmaChannel` and `CsmaNetDevice` does not model any kind of network you could build or buy, it does provide us with some useful functionality. You should, however, understand that it is explicitly not Ethernet or any flavor of IEEE 802.3 but an interesting subset.

# DSDV ROUTING

Destination-Sequenced Distance Vector (DSDV) routing protocol is a pro-active, table-driven routing protocol for MANETs developed by Charles E. Perkins and Pravin Bhagwat in 1994. It uses the hop count as metric in route selection.

This model was developed by [the ResiliNets research group](#) at the University of Kansas. A paper on this model exists at [this URL](#).

## 10.1 DSDV Routing Overview

**DSDV Routing Table:** Every node will maintain a table listing all the other nodes it has known either directly or through some neighbors. Every node has a single entry in the routing table. The entry will have information about the node's IP address, last known sequence number and the hop count to reach that node. Along with these details the table also keeps track of the nexthop neighbor to reach the destination node, the timestamp of the last update received for that node.

The DSDV update message consists of three fields, Destination Address, Sequence Number and Hop Count.

Each node uses 2 mechanisms to send out the DSDV updates. They are,

1. **Periodic Updates** Periodic updates are sent out after every `m_periodicUpdateInterval`(default:15s). In this update the node broadcasts out its entire routing table.
2. **Trigger Updates** Trigger Updates are small updates in-between the periodic updates. These updates are sent out whenever a node receives a DSDV packet that caused a change in its routing table. The original paper did not clearly mention when for what change in the table should a DSDV update be sent out. The current implementation sends out an update irrespective of the change in the routing table.

The updates are accepted based on the metric for a particular node. The first factor determining the acceptance of an update is the sequence number. It has to accept the update if the sequence number of the update message is higher irrespective of the metric. If the update with same sequence number is received, then the update with least metric (`hopCount`) is given precedence.

In highly mobile scenarios, there is a high chance of route fluctuations, thus we have the concept of weighted settling time where an update with change in metric will not be advertised to neighbors. The node waits for the settling time to make sure that it did not receive the update from its old neighbor before sending out that update.

The current implementation covers all the above features of DSDV. The current implementation also has a request queue to buffer packets that have no routes to destination. The default is set to buffer up to 5 packets per destination.

## 10.2 References

Link to the Paper: <http://portal.acm.org/citation.cfm?doid=190314.190336>



# DSR ROUTING

Dynamic Source Routing (DSR) protocol is a reactive routing protocol designed specifically for use in multi-hop wireless ad hoc networks of mobile nodes.

This model was developed by [the ResiliNets research group](#) at the University of Kansas.

## 11.1 DSR Routing Overview

This model implements the base specification of the Dynamic Source Routing (DSR) protocol. Implementation is based on RFC4728.

- Class `dsr::DsrRouting` implements all functionality of service packet exchange and inherits `IpL4Protocol`.
- Class `dsr::DsrOptions` implements functionality of packet processing and talks to `DsrRouting` to send/receive packets
- Class `dsr::DsrFsHeader` defines the fixed-size header and identifies the up-layer protocol
- Class `dsr::DsrOptionHeader` takes care of different dsr options and processes different header according to the specification from the RFC
- Class `dsr::DsrSendBuffer` is a buffer to save data packets and route error packets when there is no route to forward the packets
- Class `dsr::DsrMaintainBuffer` is a buffer to save data packets for next-hop notification when the data packet has already been sent out of send buffer
- Class `dsr::RouteCache` is the essential part to save routes found for data packets. DSR responds to several routes for a single destination
- Class `dsr::RreqTable` implements the functions to avoid duplicate route requests and control route request rate for a single destination

Protocol operation depends on many adjustable parameters. We support parameters, with their default values, from RFC and parameters that enable/disable protocol features or tune for specific simulation scenarios, such as the max size of the send buffer and its timeout value. The full parameter list is found in the `dsr-routing.cc` file.

DSR discovers routes on-demand. Therefore, our DSR model buffers all packets, while a route request packet (RREQ) is disseminated. We implement a packet buffer in `dsr-rsendbuff.cc`. The packet queue implements garbage collection of old packets and a queue size limit. When the packet is sent out from the send buffer, it will be queued in maintenance buffer for next hop acknowledgment.

The Route Cache implementation support garbage collection of old entries and state machine, as defined in the standard. It implements as a STL map container. The key is the destination IP address.

Protocol operation strongly depends on broken link detection mechanism. We implement the three heuristics recommended.

First, we use layer 2 feedback when possible. A link is considered to be broken if frame transmission results in a transmission failure for all retries. This mechanism is meant for active links and works much faster than in its absence. Layer 2 feedback implementation relies on TxErrHeader trace source, currently it is supported in AdhocWifiMac only.

Second, passive acknowledgment should be used whenever possible. The node turns on “promiscuous” receive mode, in which it can receive packets not destined for itself, and when the node assures the delivery of that data packet to its destination, it cancels the passive acknowledgment timer.

Last, we use a network layer acknowledge scheme to notify the receipt of a packet. Route request packet will not be acknowledged or retransmitted.

The following optional protocol optimizations aren’t implemented:

- Flow state
- First Hop External (F), Last Hop External (L) flags
- Handling unknown DSR options
- **Two types of error headers:**
  1. flow state not supported option
  2. unsupported option (not going to happen in simulation)

DSR operates with direct access to IP header, and operates between network and transport layer.

### 11.1.1 Implementation changes

- The DsrFsHeader has added 3 fields: message type, source id, destination id, and these changes only for post-processing
  - message type is used to identify the data packet from control packet
  - source id is used to identify the real source of the data packet since we have to deliver the packet hop-by-hop and the ipv4header is not carrying the real source and destination ip address as needed
  - destination id is for same reason of above
- Route Reply header is not word-aligned in DSR rfc, change it to word-aligned in implementation
- DSR works as a shim header between transport and network protocol, it needs its own forwarding mechanism, we are changing the packet transmission to hop-by-hop delivery, so we added two fields in dsr fixed header to notify packet delivery
  - # message type to notify the type of this packet: data packet or control one
  - # source id to identify the real source address of this packet
  - # destination id to identify the real destination

### 11.1.2 Current Route Cache implementation

This implementation used “path cache”, which is simple to implement and ensures loop-free paths:

- the path cache has automatic expire policy
- the cache saves multiple route entries for a certain destination and sort the entries based on hop counts
- the MaxEntriesEachDst can be tuned to change the maximum entries saved for a single destination
- when adding multiple routes for one destination, the route is compared based on hop-count and expire time, the one with less hop count or relatively new route is favored

- Future implementation may include “link cache” as another possibility

## 11.2 DSR Instructions

The following should be kept in mind when running DSR as routing protocol:

- `NodeTraversalTime` is the time it takes to traverse two neighboring nodes and should be chosen to fit the transmission range
- `PassiveAckTimeout` is the time a packet in maintenance buffer wait for passive acknowledgment, normally set as two times of `NodeTraversalTime`
- `RouteCacheTimeout` should be set smaller value when the nodes’ velocity become higher. The default value is 300s.

## 11.3 Helper

To have a node run DSR, the easiest way would be to use the `DsrHelper` and `DsrMainHelpers` in your simulation script. For instance:

```
DsrHelper dsr;
DsrMainHelper dsrMain;
dsrMain.Install (dsr, adhocNodes);
```

The example scripts inside `src/dsr/examples/` demonstrate the use of DSR based nodes in different scenarios. The helper source can be found inside `src/dsr/helper/dsr-main-helper.{h,cc}` and `src/dsr/helper/dsr-helper.{h,cc}`

## 11.4 Examples

The example can be found in `src/dsr/examples/`:

- `dsr.cc` use DSR as routing protocol within a traditional MANETs environment[3].

DSR is also built in the routing comparison case in `examples/routing/`:

- `manet-routing-compare.cc` is a comparison case with built in MANET routing protocols and can generate its own results.

## 11.5 Validation

This model has been tested as follows:

- Unit tests have been written to verify the internals of DSR. This can be found in `src/dsr/test/dsr-test-suite.cc`. These tests verify whether the methods inside DSR module which deal with packet buffer, headers work correctly.
- Simulation cases similar to [3] have been tested and have comparable results.
- `manet-routing-compare.cc` has been used to compare DSR with three of other routing protocols.

A paper was presented on these results at the Workshop on ns-3 in 2011.

## 11.6 References

[1] Link for the original paper:

[2] Link for RFC 4728:

[3] Link for the Broch's comparison paper:

## EMULATION OVERVIEW

*ns-3* has been designed for integration into testbed and virtual machine environments. We have addressed this need by providing two kinds of net devices. The first kind, which we call an *Emu NetDevice* allows *ns-3* simulations to send data on a “real” network. The second kind, called a *Tap NetDevice* allows a “real” host to participate in an *ns-3* simulation as if it were one of the simulated nodes. An *ns-3* simulation may be constructed with any combination of simulated, *Emu*, or *Tap* devices.

One of the use-cases we want to support is that of a testbed. A concrete example of an environment of this kind is the ORBIT testbed. ORBIT is a laboratory emulator/field trial network arranged as a two dimensional grid of 400 802.11 radio nodes. We integrate with ORBIT by using their “imaging” process to load and run *ns-3* simulations on the ORBIT array. We use our *Emu NetDevice* to drive the hardware in the testbed and we can accumulate results either using the *ns-3* tracing and logging functions, or the native ORBIT data gathering techniques. See <http://www.orbit-lab.org/> for details on the ORBIT testbed.

A simulation of this kind is shown in the following figure:

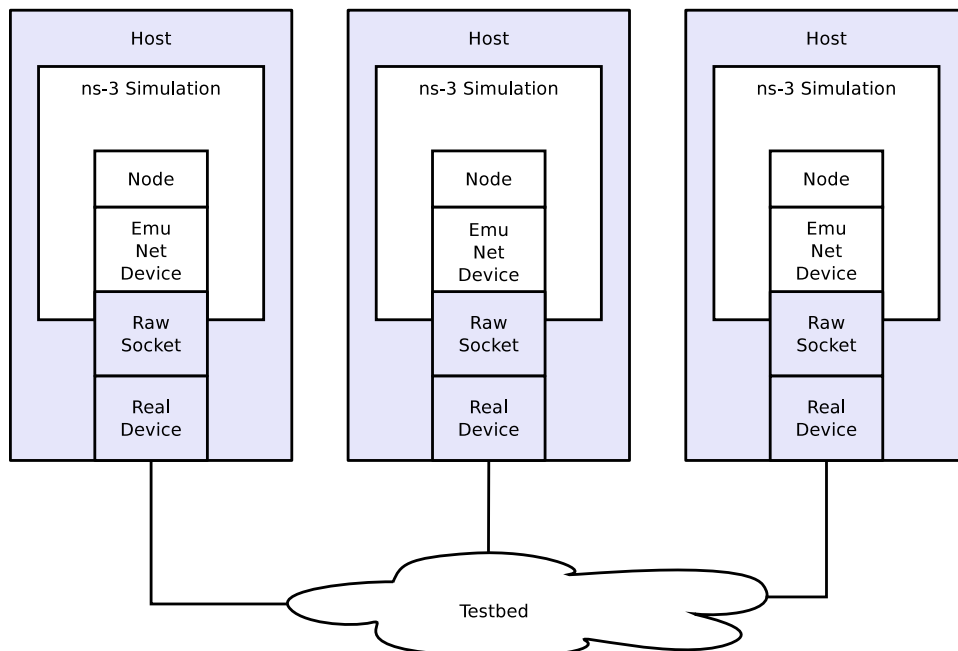

Figure 12.1: Example Implementation of Testbed Emulation.

You can see that there are separate hosts, each running a subset of a “global” simulation. Instead of an *ns-3* channel connecting the hosts, we use real hardware provided by the testbed. This allows *ns-3* applications and protocol stacks

attached to a simulation node to communicate over real hardware.

We expect the primary use for this configuration will be to generate repeatable experimental results in a real-world network environment that includes all of the *ns-3* tracing, logging, visualization and statistics gathering tools.

In what can be viewed as essentially an inverse configuration, we allow “real” machines running native applications and protocol stacks to integrate with an *ns-3* simulation. This allows for the simulation of large networks connected to a real machine, and also enables virtualization. A simulation of this kind is shown in the following figure:

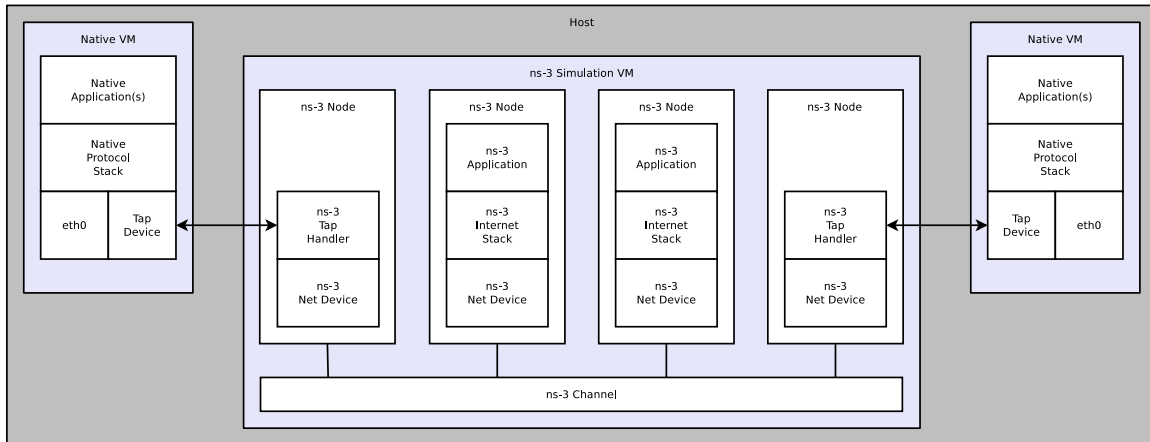

Figure 12.2: Implementation overview of emulated channel.

Here, you will see that there is a single host with a number of virtual machines running on it. An *ns-3* simulation is shown running in the virtual machine shown in the center of the figure. This simulation has a number of nodes with associated *ns-3* applications and protocol stacks that are talking to an *ns-3* channel through native simulated *ns-3* net devices.

There are also two virtual machines shown at the far left and far right of the figure. These VMs are running native (Linux) applications and protocol stacks. The VM is connected into the simulation by a Linux Tap net device. The user-mode handler for the Tap device is instantiated in the simulation and attached to a proxy node that represents the native VM in the simulation. These handlers allow the Tap devices on the native VMs to behave as if they were *ns-3* net devices in the simulation VM. This, in turn, allows the native software and protocol suites in the native VMs to believe that they are connected to the simulated *ns-3* channel.

We expect the typical use case for this environment will be to analyze the behavior of native applications and protocol suites in the presence of large simulated *ns-3* networks.

## 12.1 Emu NetDevice

### 12.1.1 Behavior

The Emu net device allows a simulation node to send and receive packets over a real network. The emulated net device relies on a specified interface being in promiscuous mode. It opens a raw socket and binds to that interface. We perform MAC spoofing to separate simulation network traffic from other network traffic that may be flowing to and from the host.

One can use the Emu net device in a testbed situation where the host on which the simulation is running has a specific interface of interest which drives the testbed hardware. You would also need to set this specific interface into promiscuous mode and provide an appropriate device name to the *ns-3* emulated net device. An example of this environment is the ORBIT testbed as described above.

The Emu net device only works if the underlying interface is up and in promiscuous mode. Packets will be sent out over the device, but we use MAC spoofing. The MAC addresses will be generated (by default) using the Organizationally Unique Identifier (OUI) 00:00:00 as a base. This vendor code is not assigned to any organization and so should not conflict with any real hardware.

It is always up to the user to determine that using these MAC addresses is okay on your network and won't conflict with anything else (including another simulation using Emu devices) on your network. If you are using the emulated net device in separate simulations you must consider global MAC address assignment issues and ensure that MAC addresses are unique across all simulations. The emulated net device respects the MAC address provided in the `SetAddress` method so you can do this manually. For larger simulations, you may want to set the OUI in the MAC address allocation function.

IP addresses corresponding to the emulated net devices are the addresses generated in the simulation, which are generated in the usual way via helper functions. Since we are using MAC spoofing, there will not be a conflict between *ns-3* network stacks and any native network stacks.

The emulated net device comes with a helper function as all *ns-3* devices do. One unique aspect is that there is no channel associated with the underlying medium. We really have no idea what this external medium is, and so have not made an effort to model it abstractly. The primary thing to be aware of is the implication this has for IPv4 global routing. The global router module attempts to walk the channels looking for adjacent networks. Since there is no channel, the global router will be unable to do this and you must then use a dynamic routing protocol such as OLSR to include routing in Emu-based networks.

## 12.1.2 Usage

Any mixing of *ns-3* objects with real objects will typically require that *ns-3* compute checksums in its protocols. By default, checksums are not computed by *ns-3*. To enable checksums (e.g. UDP, TCP, IP), users must set the attribute `ChecksumEnabled` to true, such as follows::

```
GlobalValue::Bind ("ChecksumEnabled", BooleanValue (true));
```

The usage of the Emu net device is straightforward once the network of simulations has been configured. Since most of the work involved in working with this device is in network configuration before even starting a simulation, you may want to take a moment to review a couple of HOWTO pages on the *ns-3* wiki that describe how to set up a virtual test network using VMware and how to run a set of example (client server) simulations that use Emu net devices.

- [http://www.nsnam.org/wiki/index.php/HOWTO\\_use\\_VMware\\_to\\_set\\_up\\_virtual\\_networks\\_\(Windows\)](http://www.nsnam.org/wiki/index.php/HOWTO_use_VMware_to_set_up_virtual_networks_(Windows))
- [http://www.nsnam.org/wiki/index.php/HOWTO\\_use\\_ns-3\\_scripts\\_to\\_drive\\_real\\_hardware\\_\(experimental\)](http://www.nsnam.org/wiki/index.php/HOWTO_use_ns-3_scripts_to_drive_real_hardware_(experimental))

Once you are over the configuration hurdle, the script changes required to use an Emu device are trivial. The main structural difference is that you will need to create an *ns-3* simulation script for each node. In the case of the HOWTOs above, there is one client script and one server script. The only “challenge” is to get the addresses set correctly.

Just as with all other *ns-3* net devices, we provide a helper class for the Emu net device. The following code snippet illustrates how one would declare an EmuHelper and use it to set the “DeviceName” attribute to “eth1” and install Emu devices on a group of nodes. You would do this on both the client and server side in the case of the HOWTO seen above.:

```
EmuHelper emu;
emu.SetAttribute ("DeviceName", StringValue ("eth1"));
NetDeviceContainer d = emu.Install (n);
```

The only other change that may be required is to make sure that the address spaces (MAC and IP) on the client and server simulations are compatible. First the MAC address is set to a unique well-known value in both places (illustrated here for one side).:

```
//  
// We've got the devices in place. Since we're using MAC address  
// spoofing under the sheets, we need to make sure that the MAC addresses  
// we have assigned to our devices are unique. Ns-3 will happily  
// automatically assign the same MAC address to the devices in both halves  
// of our two-script pair, so let's go ahead and just manually change them  
// to something we ensure is unique.  
//  
Ptr<NetDevice> nd = d.Get (0);  
Ptr<EmuNetDevice> ed = nd->GetObject<EmuNetDevice> ();  
ed->SetAddress ("00:00:00:00:00:02");
```

And then the IP address of the client or server is set in the usual way using helpers.:

```
//  
// We've got the "hardware" in place. Now we need to add IP addresses.  
// This is the server half of a two-script pair. We need to make sure  
// that the addressing in both of these applications is consistent, so  
// we use provide an initial address in both cases. Here, the client  
// will reside on one machine running ns-3 with one node having ns-3  
// with IP address "10.1.1.2" and talk to a server script running in  
// another ns-3 on another computer that has an ns-3 node with IP  
// address "10.1.1.3"  
//  
Ipv4AddressHelper ipv4;  
ipv4.SetBase ("10.1.1.0", "255.255.255.0", "0.0.0.2");  
Ipv4InterfaceContainer i = ipv4.Assign (d);
```

You will use application helpers to generate traffic exactly as you do in any *ns-3* simulation script. Note that the server address shown below in a snippet from the client, must correspond to the IP address assigned to the server node similarly to the snippet above.:

```
uint32_t packetSize = 1024;  
uint32_t maxPacketCount = 2000;  
Time interPacketInterval = Seconds (0.001);  
UdpEchoClientHelper client ("10.1.1.3", 9);  
client.SetAttribute ("MaxPackets", UintegerValue (maxPacketCount));  
client.SetAttribute ("Interval", TimeValue (interPacketInterval));  
client.SetAttribute ("PacketSize", UintegerValue (packetSize));  
ApplicationContainer apps = client.Install (n.Get (0));  
apps.Start (Seconds (1.0));  
apps.Stop (Seconds (2.0));
```

The Emu net device and helper provide access to ASCII and pcap tracing functionality just as other *ns-3* net devices to. You enable tracing similarly to these other net devices.:

```
EmuHelper::EnablePcapAll ("emu-udp-echo-client");
```

For examples that use the Emu net device, see `src/emu/examples/emu-udp-echo.cc` and `src/emu/examples/emu-ping.cc` in the repository.

### 12.1.3 Implementation

Perhaps the most unusual part of the Emu and Tap device implementation relates to the requirement for executing some of the code with super-user permissions. Rather than force the user to execute the entire simulation as root, we provide a small “creator” program that runs as root and does any required high-permission sockets work.



We do a similar thing for both the `Emu` and the `Tap` devices. The high-level view is that the `CreateSocket` method creates a local interprocess (Unix) socket, forks, and executes the small creation program. The small program, which runs as `suid root`, creates a raw socket and sends back the raw socket file descriptor over the Unix socket that is passed to it as a parameter. The raw socket is passed as a control message (sometimes called ancillary data) of type `SCM_RIGHTS`.

The `Emu` net device uses the *ns-3* threading and multithreaded real-time scheduler extensions. The interesting work in the `Emu` device is done when the net device is started (`EmuNetDevice::StartDevice ()`). An attribute (“Start”) provides a simulation time at which to spin up the net device. At this specified time (which defaults to `t=0`), the socket creation function is called and executes as described above. You may also specify a time at which to stop the device using the “Stop” attribute.

Once the (promiscuous mode) socket is created, we bind it to an interface name also provided as an attribute (“DeviceName”) that is stored internally as `m_deviceName::`

```
struct ifreq ifr;
bzero (&ifr, sizeof(ifr));
strncpy ((char *)ifr.ifr_name, m_deviceName.c_str (), IFNAMSIZ);

int32_t rc = ioctl (m_sock, SIOCGIFINDEX, &ifr);

struct sockaddr_ll ll;
bzero (&ll, sizeof(ll));

ll.sll_family = AF_PACKET;
ll.sll_ifindex = m_sll_ifindex;
ll.sll_protocol = htons(ETH_P_ALL);

rc = bind (m_sock, (struct sockaddr *)&ll, sizeof (ll));
```

After the promiscuous raw socket is set up, a separate thread is spawned to do reads from that socket and the link state is set to `Up`:

```
m_readThread = Create<SystemThread> (
    MakeCallback (&EmuNetDevice::ReadThread, this));
m_readThread->Start ();

NotifyLinkUp ();
```

The `EmuNetDevice::ReadThread` function basically just sits in an infinite loop reading from the promiscuous mode raw socket and scheduling packet receptions using the real-time simulator extensions:

```
for (;;)
{
    ...

    len = recvfrom (m_sock, buf, bufferSize, 0, (struct sockaddr *)&addr,
        &addrSize);

    ...

    DynamicCast<RealtimeSimulatorImpl> (Simulator::GetImplementation ())->
        ScheduleRealtimeNow (
            MakeEvent (&EmuNetDevice::ForwardUp, this, buf, len));

    ...
}
```

The line starting with our templated `DynamicCast` function probably deserves a comment. It gains access to the simulator implementation object using the `Simulator::GetImplementation` method and then casts to the

real-time simulator implementation to use the real-time schedule method `ScheduleRealtimeNow`. This function will cause a handler for the newly received packet to be scheduled for execution at the current real time clock value. This will, in turn cause the simulation clock to be advanced to that real time value when the scheduled event (`EmuNetDevice::ForwardUp`) is fired.

The `ForwardUp` function operates as most other similar *ns-3* net device methods do. The packet is first filtered based on the destination address. In the case of the `Emu` device, the MAC destination address will be the address of the `Emu` device and not the hardware address of the real device. Headers are then stripped off and the trace hooks are hit. Finally, the packet is passed up the *ns-3* protocol stack using the receive callback function of the net device.

Sending a packet is equally straightforward as shown below. The first thing we do is to add the ethernet header and trailer to the *ns-3* `Packet` we are sending. The source address corresponds to the address of the `Emu` device and not the underlying native device MAC address. This is where the MAC address spoofing is done. The trailer is added and we enqueue and dequeue the packet from the net device queue to hit the trace hooks.:

```
header.SetSource (source);
header.SetDestination (destination);
header.SetLengthType (packet->GetSize ());
packet->AddHeader (header);

EthernetTrailer trailer;
trailer.CalcFcs (packet);
packet->AddTrailer (trailer);

m_queue->Enqueue (packet);
packet = m_queue->Dequeue ();

struct sockaddr_ll ll;
bzero (&ll, sizeof (ll));

ll.sll_family = AF_PACKET;
ll.sll_ifindex = m_sll_ifindex;
ll.sll_protocol = htons (ETH_P_ALL);

rc = sendto (m_sock, packet->PeekData (), packet->GetSize (), 0,
    reinterpret_cast<struct sockaddr *> (&ll), sizeof (ll));
```

Finally, we simply send the packet to the raw socket which puts it out on the real network.

From the point of view of tracing in the net device, there are several interesting points to insert trace hooks. A convention inherited from other simulators is that packets destined for transmission onto attached networks pass through a single “transmit queue” in the net device. We provide trace hooks at this point in packet flow, which corresponds (abstractly) only to a transition from the network to data link layer, and call them collectively the device MAC hooks.

When a packet is sent to the `Emu` net device for transmission it always passes through the transmit queue. The transmit queue in the `EmuNetDevice` inherits from `Queue`, and therefore inherits three trace sources:

- An Enqueue operation source (see `Queue::m_traceEnqueue`);
- A Dequeue operation source (see `Queue::m_traceDequeue`);
- A Drop operation source (see `Queue::m_traceDrop`).

The upper-level (MAC) trace hooks for the `EmuNetDevice` are, in fact, exactly these three trace sources on the single transmit queue of the device.

The `m_traceEnqueue` event is triggered when a packet is placed on the transmit queue. This happens at the time that `ns3::EmuNetDevice::Send` or `ns3::EmuNetDevice::SendFrom` is called by a higher layer to queue a packet for transmission.

The `m_traceDequeue` event is triggered when a packet is removed from the transmit queue. Dequeues from the transmit

queue happen immediately after the packet was enqueued and only indicate that the packet is about to be sent to an underlying raw socket. The actual time at which the packet is sent out on the wire is not available.

Similar to the upper level trace hooks, there are trace hooks available at the lower levels of the net device. We call these the PHY hooks. These events fire from the device methods that talk directly to the underlying raw socket.

The trace source m\_dropTrace is not used in the Emu net device since that is really the business of the underlying “real” device driver.

The other low-level trace source fires on reception of an accepted packet (see ns3::EmuNetDevice::m\_rxTrace). A packet is accepted if it is destined for the broadcast address, a multicast address, or to the MAC address assigned to the Emu net device.

## 12.2 Tap NetDevice

The Tap NetDevice can be used to allow a host system or virtual machines to interact with a simulation.

### 12.2.1 TapBridge Model Overview

The Tap Bridge is designed to integrate “real” internet hosts (or more precisely, hosts that support Tun/Tap devices) into ns-3 simulations. The goal is to make it appear to a “real” host node in that it has an ns-3 net device as a local device. The concept of a “real host” is a bit slippery since the “real host” may actually be virtualized using readily available technologies such as VMware, VirtualBox or OpenVZ.

Since we are, in essence, connecting the inputs and outputs of an ns-3 net device to the inputs and outputs of a Linux Tap net device, we call this arrangement a Tap Bridge.

There are three basic operating modes of this device available to users. Basic functionality is essentially identical, but the modes are different in details regarding how the arrangement is created and configured; and what devices can live on which side of the bridge.

We call these three modes the ConfigureLocal, UseLocal and UseBridge modes. The first “word” in the camel case mode identifier indicates who has the responsibility for creating and configuring the taps. For example, the “Configure” in ConfigureLocal mode indicates that it is the TapBridge that has responsibility for configuring the tap. In UseLocal mode and UseBridge modes, the “Use” prefix indicates that the TapBridge is asked to “Use” an existing configuration.

In other words, in ConfigureLocal mode, the TapBridge has the responsibility for creating and configuring the TAP devices. In UseBridge or UseLocal modes, the user provides a configuration and the TapBridge adapts to that configuration.

#### TapBridge ConfigureLocal Mode

In the ConfigureLocal mode, the configuration of the tap device is ns-3 configuration-centric. Configuration information is taken from a device in the ns-3 simulation and a tap device matching the ns-3 attributes is automatically created. In this case, a Linux computer is made to appear as if it was directly connected to a simulated ns-3 network.

This is illustrated below:

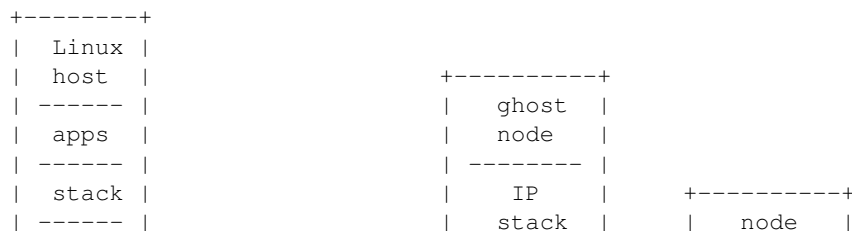

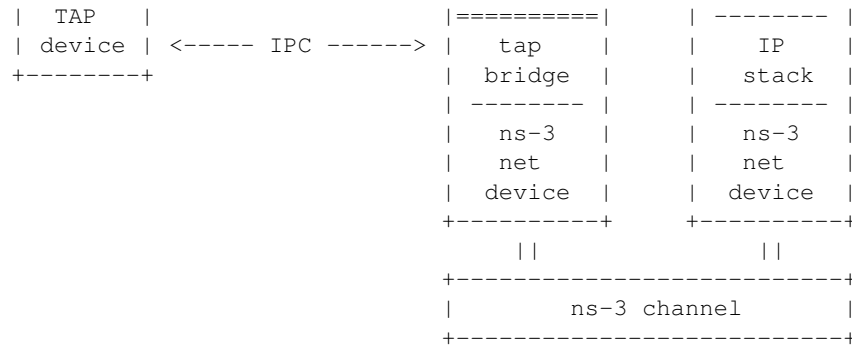

In this case, the “ns-3 net device” in the “ghost node” appears as if it were actually replacing the TAP device in the Linux host. The ns-3 simulation creates the TAP device on the underlying Linux OS and configures the IP and MAC addresses of the TAP device to match the values assigned to the simulated ns-3 net device. The “IPC” link shown above is the network tap mechanism in the underlying OS. The whole arrangement acts as a conventional bridge; but a bridge between devices that happen to have the same shared MAC and IP addresses.

Here, the user is not required to provide any configuration information specific to the tap. A tap device will be created and configured by ns-3 according to its defaults, and the tap device will have its name assigned by the underlying operating system according to its defaults.

If the user has a requirement to access the created tap device, he or she may optionally provide a “DeviceName” attribute. In this case, the created OS tap device will be named accordingly.

The ConfigureLocal mode is the default operating mode of the Tap Bridge.

### TapBridge UseLocal Mode

The UseLocal mode is quite similar to the ConfigureLocal mode. The significant difference is, as the mode name implies, the TapBridge is going to “Use” an existing tap device previously created and configured by the user. This mode is particularly useful when a virtualization scheme automatically creates tap devices and ns-3 is used to provide simulated networks for those devices.

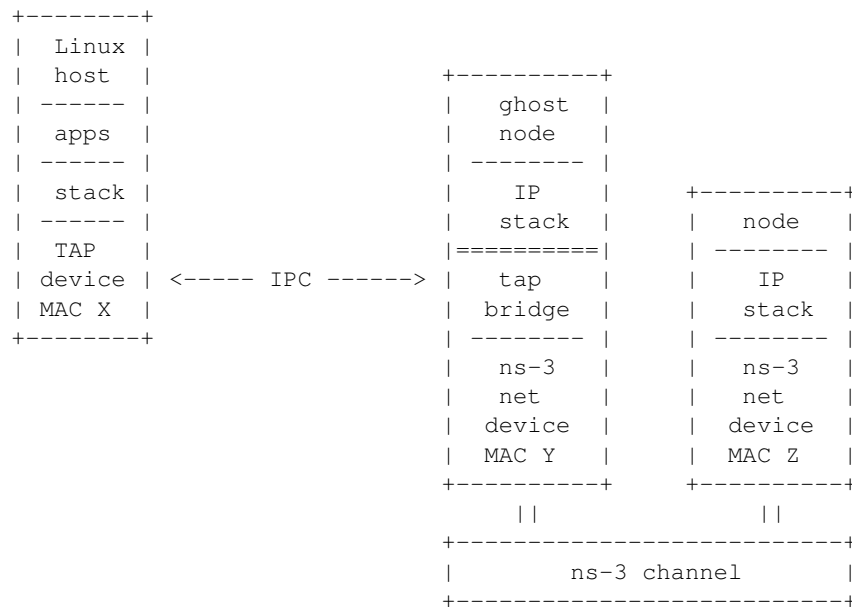

In this case, the pre-configured MAC address of the “Tap device” (MAC X) will not be the same as that of the bridged

“ns-3 net device” (MAC Y) shown in the illustration above. In order to bridge to ns-3 net devices which do not support SendFrom() (especially wireless STA nodes) we impose a requirement that only one Linux device (with one unique MAC address – here X) generates traffic that flows across the IPC link. This is because the MAC addresses of traffic across the IPC link will be “spoofed” or changed to make it appear to Linux and ns-3 that they have the same address. That is, traffic moving from the Linux host to the ns-3 ghost node will have its MAC address changed from X to Y and traffic from the ghost node to the Linux host will have its MAC address changed from Y to X. Since there is a one-to-one correspondence between devices, there may only be one MAC source flowing from the Linux side. This means that Linux bridges with more than one net device added are incompatible with UseLocal mode.

In UseLocal mode, the user is expected to create and configure a tap device completely outside the scope of the ns-3 simulation using something like:

```
sudo tuncctl -t tap0
sudo ifconfig tap0 hw ether 08:00:2e:00:00:01
sudo ifconfig tap0 10.1.1.1 netmask 255.255.255.0 up
```

To tell the TapBridge what is going on, the user will set either directly into the TapBridge or via the TapBridgeHelper, the “DeviceName” attribute. In the case of the configuration above, the “DeviceName” attribute would be set to “tap0” and the “Mode” attribute would be set to “UseLocal”.

One particular use case for this mode is in the OpenVZ environment. There it is possible to create a Tap device on the “Hardware Node” and move it into a Virtual Private Server. If the TapBridge is able to use an existing tap device it is then possible to avoid the overhead of an OS bridge in that environment.

## TapBridge UseBridge Mode

The simplest mode for those familiar with Linux networking is the UseBridge mode. Again, the “Use” prefix indicates that the TapBridge is going to Use an existing configuration. In this case, the TapBridge is going to logically extend a Linux bridge into ns-3.

This is illustrated below:

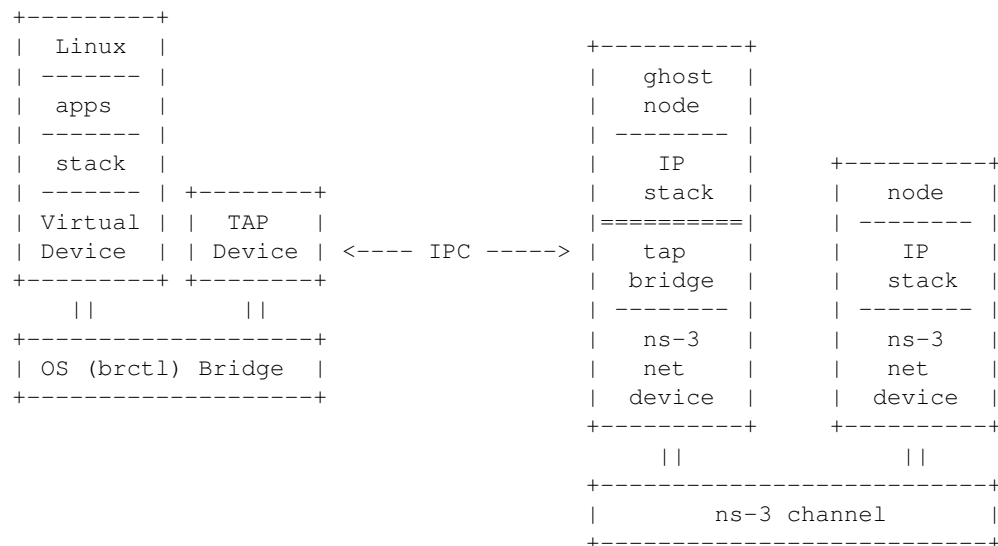

In this case, a computer running Linux applications, protocols, etc., is connected to a ns-3 simulated network in such a way as to make it appear to the Linux host that the TAP device is a real network device participating in the Linux bridge.

In the ns-3 simulation, a TapBridge is created to match each TAP Device. The name of the TAP Device is assigned to the Tap Bridge using the “DeviceName” attribute. The TapBridge then logically extends the OS bridge to encompass

the ns-3 net device.

Since this mode logically extends an OS bridge, there may be many Linux net devices on the non-ns-3 side of the bridge. Therefore, like a net device on any bridge, the ns-3 net device must deal with the possibly of many source addresses. Thus, ns-3 devices must support `SendFrom()` (`NetDevice::SupportsSendFrom()` must return true) in order to be configured for use in `UseBridge` mode.

It is expected that the user will do something like the following to configure the bridge and tap completely outside ns-3:

```
sudo brctl addbr mybridge
sudo tuncctl -t mytap
sudo ifconfig mytap hw ether 00:00:00:00:00:01
sudo ifconfig mytap 0.0.0.0 up
sudo brctl addif mybridge mytap
sudo brctl addif mybridge ...
sudo ifconfig mybridge 10.1.1.1 netmask 255.255.255.0 up
```

To tell the `TapBridge` what is going on, the user will set either directly into the `TapBridge` or via the `TapBridgeHelper`, the “`DeviceName`” attribute. In the case of the configuration above, the “`DeviceName`” attribute would be set to “`mytap`” and the “`Mode`” attribute would be set to “`UseBridge`”.

This mode is especially useful in the case of virtualization where the configuration of the virtual hosts may be dictated by another system and not be changable to suit ns-3. For example, a particular VM scheme may create virtual “`vethx`” or “`vmnetx`” devices that appear local to virtual hosts. In order to connect to such systems, one would need to manually create TAP devices on the host system and bridge these TAP devices to the existing (VM) virtual devices. The job of the Tap Bridge in this case is to extend the bridge to join a ns-3 net device.

### TapBridge ConfigureLocal Operation

In `ConfigureLocal` mode, the `TapBridge` and therefore its associated ns-3 net device appears to the Linux host computer as a network device just like any arbitrary “`eth0`” or “`ath0`” might appear. The creation and configuration of the TAP device is done by the ns-3 simulation and no manual configuration is required by the user. The IP addresses, MAC addresses, gateways, etc., for created TAP devices are extracted from the simulation itself by querying the configuration of the ns-3 device and the `TapBridge` Attributes.

Since the MAC addresses are identical on the Linux side and the ns-3 side, we can use `Send()` on the ns-3 device which is available on all ns-3 net devices. Since the MAC addresses are identical there is no requirement to hook the promiscuous callback on the receive side. Therefore there are no restrictions on the kinds of net device that are usable in `ConfigureLocal` mode.

The `TapBridge` appears to an ns-3 simulation as a channel-less net device. This device must not have an IP address associated with it, but the bridged (ns-3) net device must have an IP address. Be aware that this is the inverse of an ns-3 `BridgeNetDevice` (or a conventional bridge in general) which demands that its bridge ports not have IP addresses, but allows the bridge device itself to have an IP address.

The host computer will appear in a simulation as a “ghost” node that contains one `TapBridge` for each `NetDevice` that is being bridged. From the perspective of a simulation, the only difference between a ghost node and any other node will be the presence of the `TapBridge` devices. Note however, that the presence of the `TapBridge` does affect the connectivity of the net device to the IP stack of the ghost node.

Configuration of address information and the ns-3 devices is not changed in any way if a `TapBridge` is present. A `TapBridge` will pick up the addressing information from the ns-3 net device to which it is connected (its “bridged” net device) and use that information to create and configure the TAP device on the real host.

The end result of this is a situation where one can, for example, use the standard ping utility on a real host to ping a simulated ns-3 node. If correct routes are added to the internet host (this is expected to be done automatically in future

ns-3 releases), the routing systems in ns-3 will enable correct routing of the packets across simulated ns-3 networks. For an example of this, see the example program, `tap-wifi-dumbbell.cc` in the ns-3 distribution.

The Tap Bridge lives in a kind of a gray world somewhere between a Linux host and an ns-3 bridge device. From the Linux perspective, this code appears as the user mode handler for a TAP net device. In `ConfigureLocal` mode, this Tap device is automatically created by the ns-3 simulation. When the Linux host writes to one of these automatically created `/dev/tap` devices, the write is redirected into the TapBridge that lives in the ns-3 world; and from this perspective, the packet write on Linux becomes a packet read in the Tap Bridge. In other words, a Linux process writes a packet to a tap device and this packet is redirected by the network tap mechanism to an ns-3 process where it is received by the TapBridge as a result of a read operation there. The TapBridge then writes the packet to the ns-3 net device to which it is bridged; and therefore it appears as if the Linux host sent a packet directly through an ns-3 net device onto an ns-3 network.

In the other direction, a packet received by the ns-3 net device connected to the Tap Bridge is sent via a receive callback to the TapBridge. The TapBridge then takes that packet and writes it back to the host using the network tap mechanism. This write to the device will appear to the Linux host as if a packet has arrived on a net device; and therefore as if a packet received by the ns-3 net device during a simulation has appeared on a real Linux net device.

The upshot is that the Tap Bridge appears to bridge a tap device on a Linux host in the “real world” to an ns-3 net device in the simulation. Because the TAP device and the bridged ns-3 net device have the same MAC address and the network tap IPC link is not externalized, this particular kind of bridge makes it appear that a ns-3 net device is actually installed in the Linux host.

In order to implement this on the ns-3 side, we need a “ghost node” in the simulation to hold the bridged ns-3 net device and the TapBridge. This node should not actually do anything else in the simulation since its job is simply to make the net device appear in Linux. This is not just arbitrary policy, it is because:

- Bits sent to the TapBridge from higher layers in the ghost node (using the TapBridge Send method) are completely ignored. The TapBridge is not, itself, connected to any network, neither in Linux nor in ns-3. You can never send nor receive data over a TapBridge from the ghost node.
- The bridged ns-3 net device has its receive callback disconnected from the ns-3 node and reconnected to the Tap Bridge. All data received by a bridged device will then be sent to the Linux host and will not be received by the node. From the perspective of the ghost node, you can send over this device but you cannot ever receive.

Of course, if you understand all of the issues you can take control of your own destiny and do whatever you want – we do not actively prevent you from using the ghost node for anything you decide. You will be able to perform typical ns-3 operations on the ghost node if you so desire. The internet stack, for example, must be there and functional on that node in order to participate in IP address assignment and global routing. However, as mentioned above, interfaces talking to any TapBridge or associated bridged net devices will not work completely. If you understand exactly what you are doing, you can set up other interfaces and devices on the ghost node and use them; or take advantage of the operational send side of the bridged devices to create traffic generators. We generally recommend that you treat this node as a ghost of the Linux host and leave it to itself, though.

### TapBridge UseLocal Mode Operation

As described in above, the TapBridge acts like a bridge from the “real” world into the simulated ns-3 world. In the case of the `ConfigureLocal` mode, life is easy since the IP address of the Tap device matches the IP address of the ns-3 device and the MAC address of the Tap device matches the MAC address of the ns-3 device; and there is a one-to-one relationship between the devices.

Things are slightly complicated when a Tap device is externally configured with a different MAC address than the ns-3 net device. The conventional way to deal with this kind of difference is to use promiscuous mode in the bridged device to receive packets destined for the different MAC address and forward them off to Linux. In order to move packets the other way, the conventional solution is `SendFrom()` which allows a caller to “spoof” or change the source MAC address to match the different Linux MAC address.

We do have a specific requirement to be able to bridge Linux Virtual Machines onto wireless STA nodes. Unfortunately, the 802.11 spec doesn't provide a good way to implement `SendFrom()`, so we have to work around that problem.

To this end, we provided the `UseLocal` mode of the `Tap Bridge`. This mode allows you approach the problem as if you were creating a bridge with a single net device. A single allowed address on the Linux side is remembered in the `TapBridge`, and all packets coming from the Linux side are repeated out the ns-3 side using the ns-3 device MAC source address. All packets coming in from the ns-3 side are repeated out the Linux side using the remembered MAC address. This allows us to use `Send()` on the ns-3 device side which is available on all ns-3 net devices.

`UseLocal` mode is identical to the `ConfigureLocal` mode except for the creation and configuration of the tap device and the MAC address spoofing.

### **TapBridge UseBridge Operation**

As described in the `ConfigureLocal` mode section, when the Linux host writes to one of the `/dev/tap` devices, the write is redirected into the `TapBridge` that lives in the ns-3 world. In the case of the `UseBridge` mode, these packets will need to be sent out on the ns-3 network as if they were sent on a device participating in the Linux bridge. This means calling the `SendFrom()` method on the bridged device and providing the source MAC address found in the packet.

In the other direction, a packet received by an ns-3 net device is hooked via callback to the `TapBridge`. This must be done in promiscuous mode since the goal is to bridge the ns-3 net device onto the OS (brctl) bridge of which the TAP device is a part.

For these reasons, only ns-3 net devices that support `SendFrom()` and have a hookable promiscuous receive callback are allowed to participate in `UseBridge` mode `TapBridge` configurations.

### **12.2.2 Tap Bridge Channel Model**

There is no channel model associated with the `Tap Bridge`. In fact, the intention is make it appear that the real internet host is connected to the channel of the bridged net device.

### **12.2.3 Tap Bridge Tracing Model**

Unlike most ns-3 devices, the `TapBridge` does not provide any standard trace sources. This is because the bridge is an intermediary that is essentially one function call away from the bridged device. We expect that the trace hooks in the bridged device will be sufficient for most users,

### **12.2.4 Using the TapBridge**

We expect that most users will interact with the `TapBridge` device through the `TapBridgeHelper`. Users of other helper classes, such as `CSMA` or `Wifi`, should be comfortable with the idioms used there.



# ENERGY FRAMEWORK

Energy consumption is a key issue for wireless devices, and wireless network researchers often need to investigate the energy consumption at a node or in the overall network while running network simulations in ns-3. This requires ns-3 to support energy consumption modeling. Further, as concepts such as fuel cells and energy scavenging are becoming viable for low power wireless devices, incorporating the effect of these emerging technologies into simulations requires support for modeling diverse energy sources in ns-3. The ns-3 Energy Framework provides the basis for energy consumption and energy source modeling.

## 13.1 Model Description

The source code for the Energy Framework is currently at: `src/energy`.

### 13.1.1 Design

The ns-3 Energy Framework is composed of 2 parts: Energy Source and Device Energy Model. The framework will be implemented into the `src/energy/models` folder.

#### Energy Source

The Energy Source represents the power supply on each node. A node can have one or more energy sources, and each energy source can be connected to multiple device energy models. Connecting an energy source to a device energy model implies that the corresponding device draws power from the source. The basic functionality of the Energy Source is to provide energy for devices on the node. When energy is completely drained from the Energy Source, it notifies the devices on node such that each device can react to this event. Further, each node can access the Energy Source Objects for information such as remaining energy or energy fraction (battery level). This enables the implementation of energy aware protocols in ns-3.

In order to model a wide range of power supplies such as batteries, the Energy Source must be able to capture characteristics of these supplies. There are 2 important characteristics or effects related to practical batteries:

- Rate Capacity Effect: Decrease of battery lifetime when the current draw is higher than the rated value of the battery.
- Recovery Effect: Increase of battery lifetime when the battery is alternating between discharge and idle states.

In order to incorporate the Rate Capacity Effect, the Energy Source uses current draw from all devices on the same node to calculate energy consumption. The Energy Source polls all devices on the same node periodically to calculate the total current draw and hence the energy consumption. When a device changes state, its corresponding Device Energy Model will notify the Energy Source of this change and new total current draw will be calculated.

The Energy Source base class keeps a list of devices (Device Energy Model objects) using the particular Energy Source as power supply. When energy is completely drained, the Energy Source will notify all devices on this list. Each device can then handle this event independently, based on the desired behavior when power supply is drained.

## Device Energy Model

The Device Energy Model is the energy consumption model of a device on node. It is designed to be a state based model where each device is assumed to have a number of states, and each state is associated with a power consumption value. Whenever the state of the device changes, the corresponding Device Energy Model will notify the Energy Source of the new current draw of the device. The Energy Source will then calculate the new total current draw and update the remaining energy.

The Device Energy Model can also be used for devices that do not have finite number of states. For example, in an electric vehicle, the current draw of the motor is determined by its speed. Since the vehicle's speed can take continuous values within a certain range, it is infeasible to define a set of discrete states of operation. However, by converting the speed value into current directly, the same set of Device Energy Model APIs can still be used.

### 13.1.2 Future Work

For Device Energy Models, we are planning to include support for other PHY layer models provided in ns-3 such as WiMAX. For Energy Sources, we are planning to include new types of Energy Sources such as energy scavenging.

### 13.1.3 References

## 13.2 Usage

The main way that ns-3 users will typically interact with the Energy Framework is through the helper API and through the publicly visible attributes of the framework. The helper API is defined in `src/energy/helper/*.h`.

In order to use the energy framework, the user must install an Energy Source for the node of interest and the corresponding Device Energy Model for the network devices. Energy Source (objects) are aggregated onto each node by the Energy Source Helper. In order to allow multiple energy sources per node, we aggregate an Energy Source Container rather than directly aggregating a source object.

The Energy Source object also keeps a list of Device Energy Model objects using the source as power supply. Device Energy Model objects are installed onto the Energy Source by the Device Energy Model Helper. User can access the Device Energy Model objects through the Energy Source object to obtain energy consumption information of individual devices.

### 13.2.1 Examples

The example directories, `src/examples/energy` and `examples/energy`, contain some basic code that shows how to set up the framework.

### 13.2.2 Helpers

#### Energy Source Helper

Base helper class for Energy Source objects, this helper Aggregates Energy Source object onto a node. Child implementation of this class creates the actual Energy Source object.

## Device Energy Model Helper

Base helper class for Device Energy Model objects, this helper attaches Device Energy Model objects onto Energy Source objects. Child implementation of this class creates the actual Device Energy Model object.

### 13.2.3 Attributes

Attributes differ between Energy Sources and Devices Energy Models implementations, please look at the specific child class for details.

#### Basic Energy Source

- `BasicEnergySourceInitialEnergyJ`: Initial energy stored in basic energy source.
- `BasicEnergySupplyVoltageV`: Initial supply voltage for basic energy source.
- `PeriodicEnergyUpdateInterval`: Time between two consecutive periodic energy updates.

#### RV Battery Model

- `RvBatteryModelPeriodicEnergyUpdateInterval`: RV battery model sampling interval.
- `RvBatteryModelOpenCircuitVoltage`: RV battery model open circuit voltage.
- `RvBatteryModelCutoffVoltage`: RV battery model cutoff voltage.
- `RvBatteryModelAlphaValue`: RV battery model alpha value.
- `RvBatteryModelBetaValue`: RV battery model beta value.
- `RvBatteryModelNumOfTerms`: The number of terms of the infinite sum for estimating battery level.

#### WiFi Radio Energy Model

- `IdleCurrentA`: The default radio Idle current in Ampere.
- `CcaBusyCurrentA`: The default radio CCA Busy State current in Ampere.
- `TxCURRENTA`: The radio Tx current in Ampere.
- `RxCURRENTA`: The radio Rx current in Ampere.
- `SwitchingCurrentA`: The default radio Channel Switch current in Ampere.

### 13.2.4 Tracing

Traced values differ between Energy Sources and Devices Energy Models implementations, please look at the specific child class for details.

#### Basic Energy Source

- `RemainingEnergy`: Remaining energy at `BasicEnergySource`.

### RV Battery Model

- `RvBatteryModelBatteryLevel`: RV battery model battery level.
- `RvBatteryModelBatteryLifetime`: RV battery model battery lifetime.

### WiFi Radio Energy Model

- `TotalEnergyConsumption`: Total energy consumption of the radio device.

## 13.2.5 Validation

Comparison of the Energy Framework against actual devices have not been performed. Current implementation of the Energy Framework is checked numerically for computation errors. The RV battery model is validated by comparing results with what was presented in the original RV battery model paper.

# FLOW MONITOR

*Placeholder chapter*

This feature was added as contributed code (`src/contrib`) in *ns-3.6* and to the main distribution (`src/flow-monitor`) for *ns-3.7*. A paper on this feature is published in the proceedings of NSTools: <http://www.nstools.org/techprog.shtml>.



# INTERNET MODELS

## 15.1 Internet Stack

### 15.1.1 Internet stack aggregation

A bare class `Node` is not very useful as-is; other objects must be aggregated to it to provide useful node functionality.

The *ns-3* source code directory `src/internet` provides implementation of TCP/IPv4- and IPv6-related components. These include IPv4, ARP, UDP, TCP, IPv6, Neighbor Discovery, and other related protocols.

Internet Nodes are not subclasses of class `Node`; they are simply Nodes that have had a bunch of IPv4-related objects aggregated to them. They can be put together by hand, or via a helper function `InternetStackHelper::Install ()` which does the following to all nodes passed in as arguments::

```
void
InternetStackHelper::Install (Ptr<Node> node) const
{
    if (node->GetObject<Ipv4> () != 0)
    {
        NS_FATAL_ERROR ("InternetStackHelper::Install(): Aggregating "
                        "an InternetStack to a node with an existing Ipv4 object");
        return;
    }

    CreateAndAggregateObjectFromTypeId (node, "ns3::ArpL3Protocol");
    CreateAndAggregateObjectFromTypeId (node, "ns3::Ipv4L3Protocol");
    CreateAndAggregateObjectFromTypeId (node, "ns3::Icmpv4L4Protocol");
    CreateAndAggregateObjectFromTypeId (node, "ns3::UdpL4Protocol");
    node->AggregateObject (m_tcpFactory.Create<Object> ());
    Ptr<PacketSocketFactory> factory = CreateObject<PacketSocketFactory> ();
    node->AggregateObject (factory);
    // Set routing
    Ptr<Ipv4> ipv4 = node->GetObject<Ipv4> ();
    Ptr<Ipv4RoutingProtocol> ipv4Routing = m_routing->Create (node);
    ipv4->SetRoutingProtocol (ipv4Routing);
}
```

Where multiple implementations exist in *ns-3* (TCP, IP routing), these objects are added by a factory object (TCP) or by a routing helper (`m_routing`).

Note that the routing protocol is configured and set outside this function. By default, the following protocols are added to `Ipv4::`

```
InternetStackHelper::InternetStackHelper ()
{
    SetTcp ("ns3::TcpL4Protocol");
    static Ipv4StaticRoutingHelper staticRouting;
    static Ipv4GlobalRoutingHelper globalRouting;
    static Ipv4ListRoutingHelper listRouting;
    listRouting.Add (staticRouting, 0);
    listRouting.Add (globalRouting, -10);
    SetRoutingHelper (listRouting);
}
```

By default, IPv4 and IPv6 are enabled.

## Internet Node structure

An IPv4-capable Node (an *ns-3* Node augmented by aggregation to have one or more IP stacks) has the following internal structure.

### Layer-3 protocols

At the lowest layer, sitting above the NetDevices, are the “layer 3” protocols, including IPv4, IPv6, and ARP. The class `Ipv4L3Protocol` is an implementation class whose public interface is typically class `Ipv4`, but the `Ipv4L3Protocol` public API is also used internally at present.

In class `Ipv4L3Protocol`, one method described below is `Receive ()`:

```
/**
 * Lower layer calls this method after calling L3Demux::Lookup
 * The ARP subclass needs to know from which NetDevice this
 * packet is coming to:
 *   - implement a per-NetDevice ARP cache
 *   - send back arp replies on the right device
 */
void Receive( Ptr<NetDevice> device, Ptr<const Packet> p, uint16_t protocol,
const Address &from, const Address &to, NetDevice::PacketType packetType);
```

First, note that the `Receive ()` function has a matching signature to the `ReceiveCallback` in the class `Node`. This function pointer is inserted into the Node’s protocol handler when `AddInterface ()` is called. The actual registration is done with a statement such as follows::

```
RegisterProtocolHandler ( MakeCallback (&Ipv4Protocol::Receive, ipv4),
    Ipv4L3Protocol::PROT_NUMBER, 0);
```

The `Ipv4L3Protocol` object is aggregated to the Node; there is only one such `Ipv4L3Protocol` object. Higher-layer protocols that have a packet to send down to the `Ipv4L3Protocol` object can call `GetObject<Ipv4L3Protocol> ()` to obtain a pointer, as follows::

```
Ptr<Ipv4L3Protocol> ipv4 = m_node->GetObject<Ipv4L3Protocol> ();
if (ipv4 != 0)
{
    ipv4->Send (packet, saddr, daddr, PROT_NUMBER);
}
```

This class nicely demonstrates two techniques we exploit in *ns-3* to bind objects together: callbacks, and object aggregation.



Once IPv4 routing has determined that a packet is for the local node, it forwards it up the stack. This is done with the following function::

```
void
Ipv4L3Protocol::LocalDeliver (Ptr<const Packet> packet, Ipv4Header const&ip, uint32_t iif)
```

The first step is to find the right Ipv4L4Protocol object, based on IP protocol number. For instance, TCP is registered in the demux as protocol number 6. Finally, the `Receive()` function on the Ipv4L4Protocol (such as `TcpL4Protocol::Receive`) is called.

We have not yet introduced the class `Ipv4Interface`. Basically, each `NetDevice` is paired with an IPv4 representation of such device. In Linux, this class `Ipv4Interface` roughly corresponds to the `struct in_device`; the main purpose is to provide address-family specific information (addresses) about an interface.

All the classes have appropriate traces in order to track sent, received and lost packets. The users is encouraged to use them so to find out if (and where) a packet is dropped. A common mistake is to forget the effects of local queues when sending packets, e.g., the ARP queue. This can be particularly puzzling when sending jumbo packets or packet bursts using UDP. The ARP cache pending queue is limited (3 datagrams) and IP packets might be fragmented, easily overflowing the ARP cache queue size. In those cases it is useful to increase the ARP cache pending size to a proper value, e.g.:

```
Config::SetDefault ("ns3::ArpCache::PendingQueueSize", UintegerValue (MAX_BURST_SIZE/L2MTU*3));
```

The IPv6 implementation follows a similar architecture. Dual-stacked nodes (one with support for both IPv4 and IPv6) will allow an IPv6 socket to receive IPv4 connections as a standard dual-stacked system does. A socket bound and listening to an IPv6 endpoint can receive an IPv4 connection and will return the remote address as an IPv4-mapped address. Support for the `IPV6_V6ONLY` socket option does not currently exist.

## Layer-4 protocols and sockets

We next describe how the transport protocols, sockets, and applications tie together. In summary, each transport protocol implementation is a socket factory. An application that needs a new socket

For instance, to create a UDP socket, an application would use a code snippet such as the following::

```
Ptr<Udp> udpSocketFactory = GetNode ()->GetObject<Udp> ();
Ptr<Socket> m_socket = socketFactory->CreateSocket ();
m_socket->Bind (m_local_address);
...
```

The above will query the node to get a pointer to its UDP socket factory, will create one such socket, and will use the socket with an API similar to the C-based sockets API, such as `Connect ()` and `Send ()`. The address passed to the `Bind ()`, `Connect ()`, or `Send ()` functions may be a `Ipv4Address`, `Ipv6Address`, or `Address`. If a `Address` is passed in and contains anything other than a `Ipv4Address` or `Ipv6Address`, these functions will return an error. The `Bind (void)` and `Bind6 (void)` functions bind to “0.0.0.0” and “::” respectively. See the chapter on *ns-3* sockets for more information.

We have described so far a socket factory (e.g. `class Udp`) and a socket, which may be specialized (e.g., `class UdpSocket`). There are a few more key objects that relate to the specialized task of demultiplexing a packet to one or more receiving sockets. The key object in this task is class `Ipv4EndPointDemux`. This demultiplexer stores objects of class `Ipv4EndPoint`. This class holds the addressing/port tuple (local port, local address, destination port, destination address) associated with the socket, and a receive callback. This receive callback has a receive function registered by the socket. The `Lookup ()` function to `Ipv4EndPointDemux` returns a list of `Ipv4EndPoint` objects (there may be a list since more than one socket may match the packet). The layer-4 protocol copies the packet to each `Ipv4EndPoint` and calls its `ForwardUp ()` method, which then calls the `Receive ()` function registered by the socket.

An issue that arises when working with the sockets API on real systems is the need to manage the reading from a socket, using some type of I/O (e.g., blocking, non-blocking, asynchronous, ...). *ns-3* implements an asynchronous model for socket I/O; the application sets a callback to be notified of received data ready to be read, and the callback is invoked by the transport protocol when data is available. This callback is specified as follows::

```
void Socket::SetRecvCallback (Callback<void, Ptr<Socket>,
    Ptr<Packet>, const Address&> receivedData);
```

The data being received is conveyed in the Packet data buffer. An example usage is in class PacketSink::

```
m_socket->SetRecvCallback (MakeCallback(&PacketSink::HandleRead, this));
```

To summarize, internally, the UDP implementation is organized as follows:

- a `UdpImpl` class that implements the UDP socket factory functionality
- a `UdpL4Protocol` class that implements the protocol logic that is socket-independent
- a `UdpSocketImpl` class that implements socket-specific aspects of UDP
- a class called `Ipv4EndPoint` that stores the addressing tuple (local port, local address, destination port, destination address) associated with the socket, and a receive callback for the socket.

### Ipv4-capable node interfaces

Many of the implementation details, or internal objects themselves, of Ipv4-capable Node objects are not exposed at the simulator public API. This allows for different implementations; for instance, replacing the native *ns-3* models with ported TCP/IP stack code.

The C++ public APIs of all of these objects is found in the `src/network` directory, including principally:

- `address.h`
- `socket.h`
- `node.h`
- `packet.h`

These are typically base class objects that implement the default values used in the implementation, implement access methods to get/set state variables, host attributes, and implement publicly-available methods exposed to clients such as `CreateSocket`.

### Example path of a packet

These two figures show an example stack trace of how packets flow through the Internet Node objects.

## 15.2 IPv4

*Placeholder chapter*

## 15.3 IPv6

*Placeholder chapter*

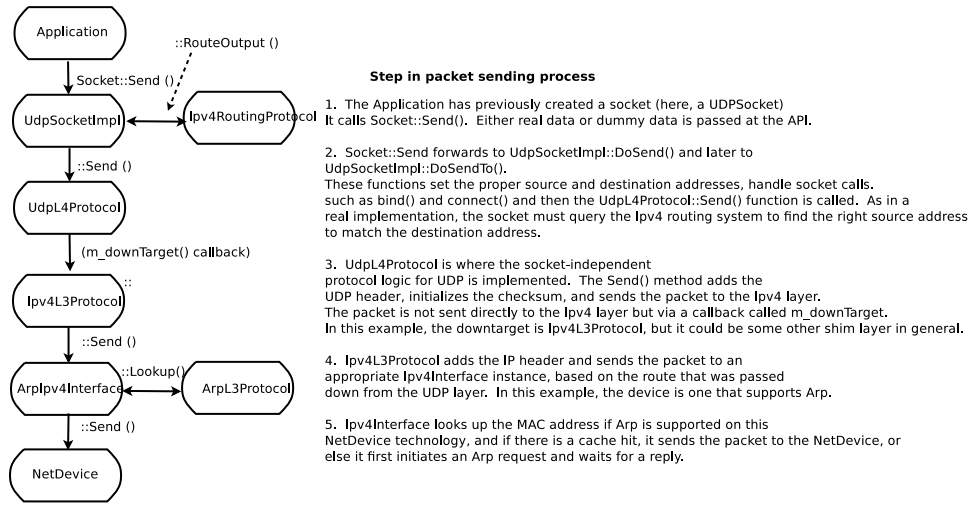

Figure 15.1: Send path of a packet.

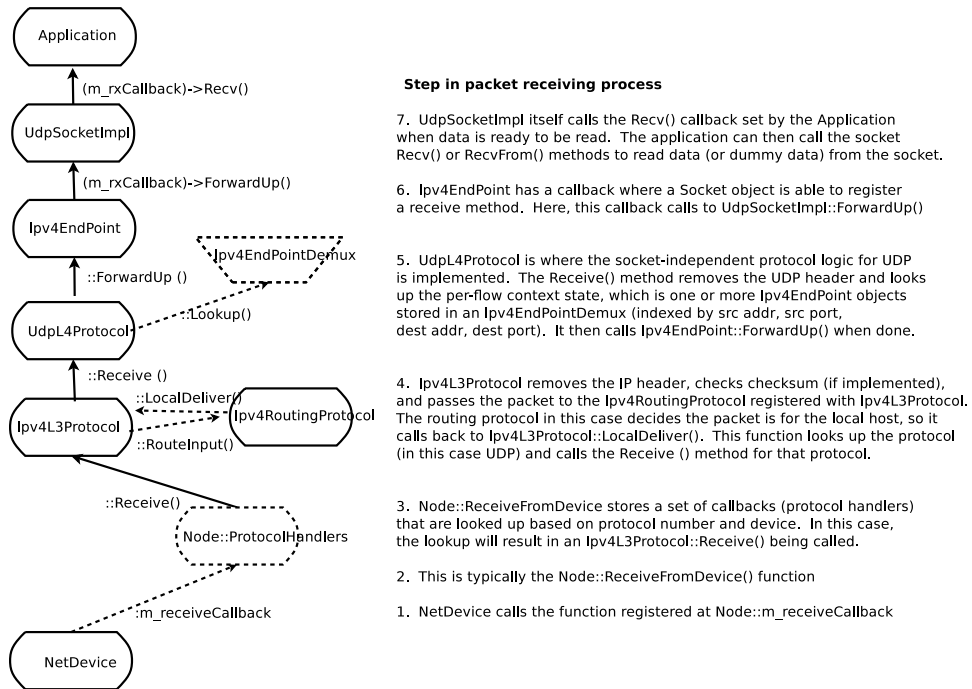

Figure 15.2: Receive path of a packet.

## 15.4 Routing overview

*ns-3* is intended to support traditional routing approaches and protocols, support ports of open source routing implementations, and facilitate research into unorthodox routing techniques. The overall routing architecture is described below in *Routing architecture*. Users who wish to just read about how to configure global routing for wired topologies can read *Global centralized routing*. Unicast routing protocols are described in *Unicast routing*. Multicast routing is documented in *Multicast routing*.

### 15.4.1 Routing architecture

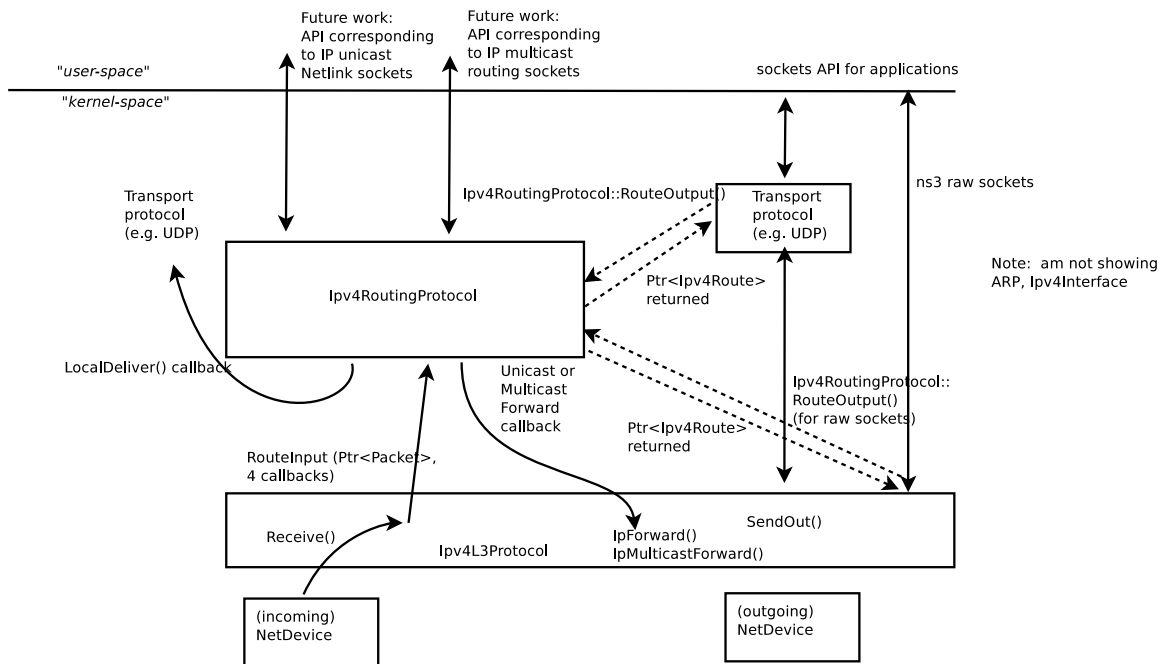

Figure 15.3: Overview of routing

*Overview of routing* shows the overall routing architecture for IPv4. The key objects are Ipv4L3Protocol, Ipv4RoutingProtocol(s) (a class to which all routing/forwarding has been delegated from Ipv4L3Protocol), and Ipv4Route(s).

Ipv4L3Protocol must have at least one Ipv4RoutingProtocol added to it at simulation setup time. This is done explicitly by calling `Ipv4::SetRoutingProtocol()`.

The abstract base class `Ipv4RoutingProtocol()` declares a minimal interface, consisting of two methods: `RouteOutput()` and `RouteInput()`. For packets traveling outbound from a host, the transport protocol will query Ipv4 for the Ipv4RoutingProtocol object interface, and will request a route via `Ipv4RoutingProtocol::RouteOutput()`. A `Ptr` to `Ipv4Route` object is returned. This is analogous to a `dst_cache` entry in Linux. The `Ipv4Route` is carried down to the Ipv4L3Protocol to avoid a second lookup there. However, some cases (e.g. IPv4 raw sockets) will require a call to `RouteOutput()` directly from Ipv4L3Protocol.

For packets received inbound for forwarding or delivery, the following steps occur. `Ipv4L3Protocol::Receive()` calls `Ipv4RoutingProtocol::RouteInput()`. This passes the packet ownership to the Ipv4RoutingProtocol object. There are four callbacks associated with this call:

- LocalDeliver
- UnicastForward

- MulticastForward
- Error

The Ipv4RoutingProtocol must eventually call one of these callbacks for each packet that it takes responsibility for. This is basically how the input routing process works in Linux.

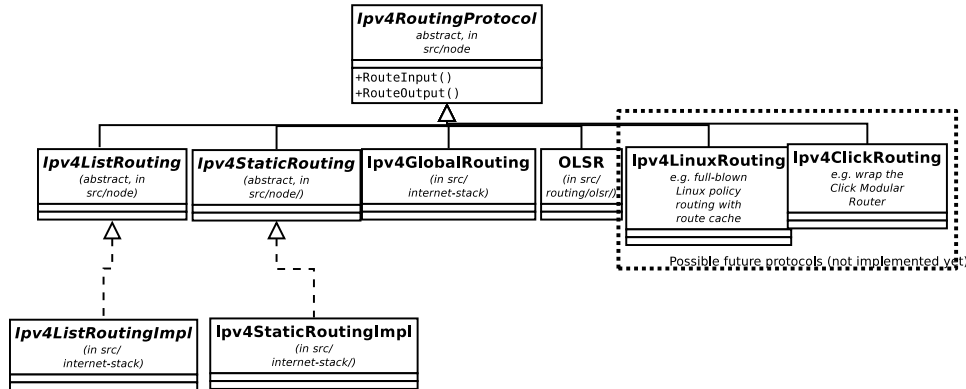

Figure 15.4: Ipv4Routing specialization.

This overall architecture is designed to support different routing approaches, including (in the future) a Linux-like policy-based routing implementation, proactive and on-demand routing protocols, and simple routing protocols for when the simulation user does not really care about routing.

*Ipv4Routing specialization.* illustrates how multiple routing protocols derive from this base class. A class Ipv4ListRouting (implementation class Ipv4ListRoutingImpl) provides the existing list routing approach in ns-3. Its API is the same as base class Ipv4Routing except for the ability to add multiple prioritized routing protocols (Ipv4ListRouting::AddRoutingProtocol(), Ipv4ListRouting::GetRoutingProtocol()).

The details of these routing protocols are described below in *Unicast routing*. For now, we will first start with a basic unicast routing capability that is intended to globally build routing tables at simulation time  $t=0$  for simulation users who do not care about dynamic routing.

## 15.4.2 Global centralized routing

Global centralized routing is sometimes called “God” routing; it is a special implementation that walks the simulation topology and runs a shortest path algorithm, and populates each node’s routing tables. No actual protocol overhead (on the simulated links) is incurred with this approach. It does have a few constraints:

- **Wired only:** It is not intended for use in wireless networks.
- **Unicast only:** It does not do multicast.
- **Scalability:** Some users of this on large topologies (e.g. 1000 nodes) have noticed that the current implementation is not very scalable. The global centralized routing will be modified in the future to reduce computations and runtime performance.

Presently, global centralized IPv4 unicast routing over both point-to-point and shared (CSMA) links is supported.

By default, when using the ns-3 helper API and the default InternetStackHelper, global routing capability will be added to the node, and global routing will be inserted as a routing protocol with lower priority than the static routes (i.e., users can insert routes via Ipv4StaticRouting API and they will take precedence over routes found by global routing).

## Global Unicast Routing API

The public API is very minimal. User scripts include the following::

```
#include "ns3/internet-module.h"
```

If the default `InternetStackHelper` is used, then an instance of global routing will be aggregated to each node. After IP addresses are configured, the following function call will cause all of the nodes that have an `Ipv4` interface to receive forwarding tables entered automatically by the `GlobalRouteManager`::

```
Ipv4GlobalRoutingHelper::PopulateRoutingTables ();
```

*Note:* A reminder that the wifi `NetDevice` will work but does not take any wireless effects into account. For wireless, we recommend OLSR dynamic routing described below.

It is possible to call this function again in the midst of a simulation using the following additional public function::

```
Ipv4GlobalRoutingHelper::RecomputeRoutingTables ();
```

which flushes the old tables, queries the nodes for new interface information, and rebuilds the routes.

For instance, this scheduling call will cause the tables to be rebuilt at time 5 seconds::

```
Simulator::Schedule (Seconds (5),  
    &Ipv4GlobalRoutingHelper::RecomputeRoutingTables);
```

There are two attributes that govern the behavior. The first is `Ipv4GlobalRouting::RandomEcmpRouting`. If set to true, packets are randomly routed across equal-cost multipath routes. If set to false (default), only one route is consistently used. The second is `Ipv4GlobalRouting::RespondToInterfaceEvents`. If set to true, dynamically recompute the global routes upon `Interface` notification events (up/down, or add/remove address). If set to false (default), routing may break unless the user manually calls `RecomputeRoutingTables()` after such events. The default is set to false to preserve legacy *ns-3* program behavior.

## Global Routing Implementation

This section is for those readers who care about how this is implemented. A singleton object (`GlobalRouteManager`) is responsible for populating the static routes on each node, using the public `Ipv4` API of that node. It queries each node in the topology for a “globalRouter” interface. If found, it uses the API of that interface to obtain a “link state advertisement (LSA)” for the router. Link State Advertisements are used in OSPF routing, and we follow their formatting.

It is important to note that all of these computations are done before packets are flowing in the network. In particular, there are no overhead or control packets being exchanged when using this implementation. Instead, this global route manager just walks the list of nodes to build the necessary information and configure each node’s routing table.

The `GlobalRouteManager` populates a link state database with LSAs gathered from the entire topology. Then, for each router in the topology, the `GlobalRouteManager` executes the OSPF shortest path first (SPF) computation on the database, and populates the routing tables on each node.

The quagga (<http://www.quagga.net>) OSPF implementation was used as the basis for the routing computation logic. One benefit of following an existing OSPF SPF implementation is that OSPF already has defined link state advertisements for all common types of network links:

- point-to-point (serial links)
- point-to-multipoint (Frame Relay, ad hoc wireless)
- non-broadcast multiple access (ATM)
- broadcast (Ethernet)

Therefore, we think that enabling these other link types will be more straightforward now that the underlying OSPF SPF framework is in place.

Presently, we can handle IPv4 point-to-point, numbered links, as well as shared broadcast (CSMA) links. Equal-cost multipath is also supported. Although wireless link types are supported by the implementation, note that due to the nature of this implementation, any channel effects will not be considered and the routing tables will assume that every node on the same shared channel is reachable from every other node (i.e. it will be treated like a broadcast CSMA link).

The GlobalRouteManager first walks the list of nodes and aggregates a GlobalRouter interface to each one as follows::

```
typedef std::vector < Ptr<Node> >::iterator Iterator;
for (Iterator i = NodeList::Begin (); i != NodeList::End (); i++)
{
    Ptr<Node> node = *i;
    Ptr<GlobalRouter> globalRouter = CreateObject<GlobalRouter> (node);
    node->AggregateObject (globalRouter);
}
```

This interface is later queried and used to generate a Link State Advertisement for each router, and this link state database is fed into the OSPF shortest path computation logic. The Ipv4 API is finally used to populate the routes themselves.

### 15.4.3 Unicast routing

There are presently seven unicast routing protocols defined for IPv4 and two for IPv6:

- class Ipv4StaticRouting (covering both unicast and multicast)
- IPv4 Optimized Link State Routing (OLSR) (a MANET protocol defined in [RFC 3626](#))
- IPv4 Ad Hoc On Demand Distance Vector (AODV) (a MANET protocol defined in [RFC 3561](#))
- IPv4 Destination Sequenced Distance Vector (DSDV) (a MANET protocol)
- class Ipv4ListRouting (used to store a prioritized list of routing protocols)
- class Ipv4GlobalRouting (used to store routes computed by the global route manager, if that is used)
- class Ipv4NixVectorRouting (a more efficient version of global routing that stores source routes in a packet header field)
- class Ipv6ListRouting (used to store a prioritized list of routing protocols)
- class Ipv6StaticRouting

In the future, this architecture should also allow someone to implement a Linux-like implementation with routing cache, or a Click modular router, but those are out of scope for now.

#### Ipv4ListRouting

This section describes the current default *ns-3* Ipv4RoutingProtocol. Typically, multiple routing protocols are supported in user space and coordinate to write a single forwarding table in the kernel. Presently in *ns-3*, the implementation instead allows for multiple routing protocols to build/keep their own routing state, and the IPv4 implementation will query each one of these routing protocols (in some order determined by the simulation author) until a route is found.

We chose this approach because it may better facilitate the integration of disparate routing approaches that may be difficult to coordinate the writing to a single table, approaches where more information than destination IP address

(e.g., source routing) is used to determine the next hop, and on-demand routing approaches where packets must be cached.

### **Ipv4ListRouting::AddRoutingProtocol**

Class `Ipv4ListRouting` provides a pure virtual function declaration for the method that allows one to add a routing protocol::

```
void AddRoutingProtocol (Ptr<Ipv4RoutingProtocol> routingProtocol,  
                        int16_t priority);
```

This method is implemented by class `Ipv4ListRoutingImpl` in the `internet-stack` module.

The priority variable above governs the priority in which the routing protocols are inserted. Notice that it is a signed int. By default in *ns-3*, the helper classes will instantiate a `Ipv4ListRoutingImpl` object, and add to it an `Ipv4StaticRoutingImpl` object at priority zero. Internally, a list of `Ipv4RoutingProtocols` is stored, and the routing protocols are each consulted in decreasing order of priority to see whether a match is found. Therefore, if you want your `Ipv4RoutingProtocol` to have priority lower than the static routing, insert it with priority less than 0; e.g.::

```
Ptr<MyRoutingProtocol> myRoutingProto = CreateObject<MyRoutingProtocol> ();  
listRoutingPtr->AddRoutingProtocol (myRoutingProto, -10);
```

Upon calls to `RouteOutput()` or `RouteInput()`, the list routing object will search the list of routing protocols, in priority order, until a route is found. Such routing protocol will invoke the appropriate callback and no further routing protocols will be searched.

### **Optimized Link State Routing (OLSR)**

This IPv4 routing protocol was originally ported from the OLSR-UM implementation for *ns-2*. The implementation is found in the `src/olsr` directory, and an example script is in `examples/simple-point-to-point-olsr.cc`.

Typically, OLSR is enabled in a main program by use of an `OlsrHelper` class that installs OLSR into an `Ipv4ListRoutingProtocol` object. The following sample commands will enable OLSR in a simulation using this helper class along with some other routing helper objects. The setting of priority value 10, ahead of the staticRouting priority of 0, means that OLSR will be consulted for a route before the node's static routing table.:

```
NodeContainer c;  
...  
// Enable OLSR  
NS_LOG_INFO ("Enabling OLSR Routing.");  
OlsrHelper olsr;  
  
Ipv4StaticRoutingHelper staticRouting;  
  
Ipv4ListRoutingHelper list;  
list.Add (staticRouting, 0);  
list.Add (olsr, 10);  
  
InternetStackHelper internet;  
internet.SetRoutingHelper (list);  
internet.Install (c);
```

Once installed, the OLSR “main interface” can be set with the `SetMainInterface()` command. If the user does not specify a main address, the protocol will select the first primary IP address that it finds, starting first the loopback interface and then the next non-loopback interface found, in order of IPv4 interface index. The loopback address of 127.0.0.1 is not selected. In addition, a number of protocol constants are defined in `olsr-routing-protocol.cc`.



Olsr is started at time zero of the simulation, based on a call to `Object::Start()` that eventually calls `OlsrRoutingProtocol::DoStart()`. Note: a patch to allow the user to start and stop the protocol at other times would be welcome.

Presently, OLSR is limited to use with an `Ipv4ListRouting` object, and does not respond to dynamic changes to a device's IP address or link up/down notifications; i.e. the topology changes are due to loss/gain of connectivity over a wireless channel.

### 15.4.4 Multicast routing

The following function is used to add a static multicast route to a node::

```
void
Ipv4StaticRouting::AddMulticastRoute (Ipv4Address origin,
                                       Ipv4Address group,
                                       uint32_t inputInterface,
                                       std::vector<uint32_t> outputInterfaces);
```

A multicast route must specify an origin IP address, a multicast group and an input network interface index as conditions and provide a vector of output network interface indices over which packets matching the conditions are sent.

Typically there are two main types of multicast routes: routes of the first kind are used during forwarding. All of the conditions must be explicitly provided. The second kind of routes are used to get packets off of a local node. The difference is in the input interface. Routes for forwarding will always have an explicit input interface specified. Routes off of a node will always set the input interface to a wildcard specified by the index `Ipv4RoutingProtocol::IF_INDEX_ANY`.

For routes off of a local node wildcards may be used in the origin and multicast group addresses. The wildcard used for `Ipv4Addresses` is that address returned by `Ipv4Address::GetAny ()` – typically “0.0.0.0”. Usage of a wildcard allows one to specify default behavior to varying degrees.

For example, making the origin address a wildcard, but leaving the multicast group specific allows one (in the case of a node with multiple interfaces) to create different routes using different output interfaces for each multicast group.

If the origin and multicast addresses are made wildcards, you have created essentially a default multicast address that can forward to multiple interfaces. Compare this to the actual default multicast address that is limited to specifying a single output interface for compatibility with existing functionality in other systems.

Another command sets the default multicast route::

```
void
Ipv4StaticRouting::SetDefaultMulticastRoute (uint32_t outputInterface);
```

This is the multicast equivalent of the unicast version `SetDefaultRoute`. We tell the routing system what to do in the case where a specific route to a destination multicast group is not found. The system forwards packets out the specified interface in the hope that “something out there” knows better how to route the packet. This method is only used in initially sending packets off of a host. The default multicast route is not consulted during forwarding – exact routes must be specified using `AddMulticastRoute` for that case.

Since we're basically sending packets to some entity we think may know better what to do, we don't pay attention to “subtleties” like origin address, nor do we worry about forwarding out multiple interfaces. If the default multicast route is set, it is returned as the selected route from `LookupStatic` irrespective of origin or multicast group if another specific route is not found.

Finally, a number of additional functions are provided to fetch and remove multicast routes::

```
uint32_t GetNMulticastRoutes (void) const;

Ipv4MulticastRoute *GetMulticastRoute (uint32_t i) const;

Ipv4MulticastRoute *GetDefaultMulticastRoute (void) const;
```

```
bool RemoveMulticastRoute (Ipv4Address origin,
                           Ipv4Address group,
                           uint32_t inputInterface);

void RemoveMulticastRoute (uint32_t index);
```

## 15.5 TCP models in ns-3

This chapter describes the TCP models available in *ns-3*.

### 15.5.1 Generic support for TCP

*ns-3* was written to support multiple TCP implementations. The implementations inherit from a few common header classes in the `src/network` directory, so that user code can swap out implementations with minimal changes to the scripts.

There are two important abstract base classes:

- **class `TcpSocket`:** This is defined in `src/internet/model/tcp-socket.{cc,h}`. This class exists for hosting `TcpSocket` attributes that can be reused across different implementations. For instance, the attribute `InitialCwnd` can be used for any of the implementations that derive from class `TcpSocket`.
- **class `TcpSocketFactory`:** This is used by the layer-4 protocol instance to create TCP sockets of the right type.

There are presently two implementations of TCP available for *ns-3*.

- a natively implemented TCP for ns-3
- support for the [Network Simulation Cradle \(NSC\)](#)

It should also be mentioned that various ways of combining virtual machines with *ns-3* makes available also some additional TCP implementations, but those are out of scope for this chapter.

### 15.5.2 ns-3 TCP

Until ns-3.10 release, *ns-3* contained a port of the TCP model from [GTNetS](#). This implementation was substantially rewritten by Adriam Tam for ns-3.10. The model is a full TCP, in that it is bidirectional and attempts to model the connection setup and close logic.

The implementation of TCP is contained in the following files::

```
src/internet/model/tcp-header.{cc,h}
src/internet/model/tcp-l4-protocol.{cc,h}
src/internet/model/tcp-socket-factory-impl.{cc,h}
src/internet/model/tcp-socket-base.{cc,h}
src/internet/model/tcp-tx-buffer.{cc,h}
src/internet/model/tcp-rx-buffer.{cc,h}
src/internet/model/tcp-rfc793.{cc,h}
src/internet/model/tcp-tahoe.{cc,h}
src/internet/model/tcp-reno.{cc,h}
src/internet/model/tcp-newreno.{cc,h}
src/internet/model/rtt-estimator.{cc,h}
src/network/model/sequence-number.{cc,h}
```

Different variants of TCP congestion control are supported by subclassing the common base class `TcpSocketBase`. Several variants are supported, including RFC 793 (no congestion control), Tahoe, Reno, and NewReno. NewReno is used by default.

## Usage

In many cases, usage of TCP is set at the application layer by telling the *ns-3* application which kind of socket factory to use.

Using the helper functions defined in `src/applications/helper` and `src/network/helper`, here is how one would create a TCP receiver::

```
// Create a packet sink on the star "hub" to receive these packets
uint16_t port = 50000;
Address sinkLocalAddress(InetSocketAddress (Ipv4Address::GetAny (), port));
PacketSinkHelper sinkHelper ("ns3::TcpSocketFactory", sinkLocalAddress);
ApplicationContainer sinkApp = sinkHelper.Install (serverNode);
sinkApp.Start (Seconds (1.0));
sinkApp.Stop (Seconds (10.0));
```

Similarly, the below snippet configures `OnOffApplication` traffic source to use TCP::

```
// Create the OnOff applications to send TCP to the server
OnOffHelper clientHelper ("ns3::TcpSocketFactory", Address ());
```

The careful reader will note above that we have specified the `TypeId` of an abstract base class `TcpSocketFactory`. How does the script tell *ns-3* that it wants the native *ns-3* TCP vs. some other one? Well, when internet stacks are added to the node, the default TCP implementation that is aggregated to the node is the *ns-3* TCP. This can be overridden as we show below when using Network Simulation Cradle. So, by default, when using the *ns-3* helper API, the TCP that is aggregated to nodes with an Internet stack is the native *ns-3* TCP.

To configure behavior of TCP, a number of parameters are exported through the *ns-3* attribute system. These are documented in the *Doxygen* <[http://www.nsnam.org/doxygen/classns3\\_1\\_1\\_tcp\\_socket.html](http://www.nsnam.org/doxygen/classns3_1_1_tcp_socket.html)> for class `TcpSocket`. For example, the maximum segment size is a settable attribute.

To set the default socket type before any internet stack-related objects are created, one may put the following statement at the top of the simulation program::

```
Config::SetDefault ("ns3::TcpL4Protocol::SocketType", StringValue ("ns3::TcpTahoe"));
```

For users who wish to have a pointer to the actual socket (so that socket operations like `Bind()`, setting socket options, etc. can be done on a per-socket basis), `Tcp` sockets can be created by using the `Socket::CreateSocket()` method. The `TypeId` passed to `CreateSocket()` must be of type `ns3::SocketFactory`, so configuring the underlying socket type must be done by twiddling the attribute associated with the underlying `TcpL4Protocol` object. The easiest way to get at this would be through the attribute configuration system. In the below example, the Node container “n0n1” is accessed to get the zeroth element, and a socket is created on this node::

```
// Create and bind the socket...
TypeId tid = TypeId::LookupByName ("ns3::TcpTahoe");
Config::Set ("/NodeList/*/ns3::TcpL4Protocol/SocketType", TypeIdValue (tid));
Ptr<Socket> localSocket =
    Socket::CreateSocket (n0n1.Get (0), TcpSocketFactory::GetTypeId ());
```

Above, the “\*” wild card for node number is passed to the attribute configuration system, so that all future sockets on all nodes are set to Tahoe, not just on node ‘n0n1.Get (0)’. If one wants to limit it to just the specified node, one would have to do something like::

```
// Create and bind the socket...
TypeId tid = TypeId::LookupByName ("ns3::TcpTahoe");
std::stringstream nodeId;
nodeId << n0nl.Get (0)->GetId ();
std::string specificNode = "/NodeList/" + nodeId.str () + "/$ns3::TcpL4Protocol/SocketType";
Config::Set (specificNode, TypeIdValue (tid));
Ptr<Socket> localSocket =
    Socket::CreateSocket (n0nl.Get (0), TcpSocketFactory::GetTypeId ());
```

Once a TCP socket is created, one will want to follow conventional socket logic and either `connect()` and `send()` (for a TCP client) or `bind()`, `listen()`, and `accept()` (for a TCP server). See *Sockets APIs* for a review of how sockets are used in *ns-3*.

### Validation

Several TCP validation test results can be found in the [wiki page](#) describing this implementation.

### Current limitations

- Only IPv4 is supported
- Neither the Nagle algorithm nor SACK are supported

## 15.5.3 Network Simulation Cradle

The [Network Simulation Cradle \(NSC\)](#) is a framework for wrapping real-world network code into simulators, allowing simulation of real-world behavior at little extra cost. This work has been validated by comparing situations using a test network with the same situations in the simulator. To date, it has been shown that the NSC is able to produce extremely accurate results. NSC supports four real world stacks: FreeBSD, OpenBSD, lwIP and Linux. Emphasis has been placed on not changing any of the network stacks by hand. Not a single line of code has been changed in the network protocol implementations of any of the above four stacks. However, a custom C parser was built to programmatically change source code.

NSC has previously been ported to *ns-2* and OMNeT++, and recently was added to *ns-3*. This section describes the *ns-3* port of NSC and how to use it.

### Prerequisites

Presently, NSC has been tested and shown to work on these platforms: Linux i386 and Linux x86-64. NSC does not support powerpc.

Building NSC requires the packages flex and bison.

### Configuring and Downloading

Using the `build.py` script in `ns-3-allinone` directory, NSC will be enabled by default unless the platform does not support it. To disable it when building *ns-3*, type::

```
./waf configure --enable-examples --enable-tests --disable-nsc
```

## Building and validating

Building *ns-3* with nsc support is the same as building it without; no additional arguments are needed for waf. Building nsc may take some time compared to *ns-3*; it is interleaved in the *ns-3* building process.

Try running the following ns-3 test suite::

```
./test.py -s ns3-tcp-interoperability
```

If NSC has been successfully built, the following test should show up in the results::

```
PASS TestSuite ns3-tcp-interoperability
```

This confirms that NSC is ready to use.

## Usage

There are a few example files. Try:

```
./waf --run tcp-nsc-zoo
./waf --run tcp-nsc-lfn
```

These examples will deposit some `.pcap` files in your directory, which can be examined by `tcpdump` or `wireshark`.

Let's look at the `examples/tcp/tcp-nsc-zoo.cc` file for some typical usage. How does it differ from using native *ns-3* TCP? There is one main configuration line, when using NSC and the *ns-3* helper API, that needs to be set::

```
InternetStackHelper internetStack;

internetStack.SetNscStack ("liblinux2.6.26.so");
// this switches nodes 0 and 1 to NSCs Linux 2.6.26 stack.
internetStack.Install (n.Get(0));
internetStack.Install (n.Get(1));
```

The key line is the `SetNscStack`. This tells the `InternetStack` helper to aggregate instances of NSC TCP instead of native *ns-3* TCP to the remaining nodes. It is important that this function be called **before** calling the `Install()` function, as shown above.

Which stacks are available to use? Presently, the focus has been on Linux 2.6.18 and Linux 2.6.26 stacks for *ns-3*. To see which stacks were built, one can execute the following `find` command at the *ns-3* top level directory::

```
~/ns-3.10> find nsc -name "*.so" -type f
nsc/linux-2.6.18/liblinux2.6.18.so
nsc/linux-2.6.26/liblinux2.6.26.so
```

This tells us that we may either pass the library name `liblinux2.6.18.so` or `liblinux2.6.26.so` to the above configuration step.

## Stack configuration

NSC TCP shares the same configuration attributes that are common across TCP sockets, as described above and documented in [Doxygen](#)

Additionally, NSC TCP exports a lot of configuration variables into the *ns-3* attributes system, via a `sysctl`-like interface. In the `examples/tcp/tcp-nsc-zoo` example, you can see the following configuration::

```
// this disables TCP SACK, wscale and timestamps on node 1 (the attributes
   represent sysctl-values).
Config::Set ("/NodeList/1/$ns3::Ns3NscStack<linux2.6.26>/net.ipv4.tcp_sack",
   StringValue ("0"));
Config::Set ("/NodeList/1/$ns3::Ns3NscStack<linux2.6.26>/net.ipv4.tcp_timestamps",
   StringValue ("0"));
Config::Set ("/NodeList/1/$ns3::Ns3NscStack<linux2.6.26>/net.ipv4.tcp_window_scaling",
   StringValue ("0"));
```

These additional configuration variables are not available to native *ns-3* TCP.

## NSC API

This subsection describes the API that NSC presents to *ns-3* or any other simulator. NSC provides its API in the form of a number of classes that are defined in `sim/sim_interface.h` in the `nsc` directory.

- **INetStack** INetStack contains the ‘low level’ operations for the operating system network stack, e.g. in and output functions from and to the network stack (think of this as the ‘network driver interface’. There are also functions to create new TCP or UDP sockets.
- **ISendCallback** This is called by NSC when a packet should be sent out to the network. This simulator should use this callback to re-inject the packet into the simulator so the actual data can be delivered/routed to its destination, where it will eventually be handed into Receive() (and eventually back to the receivers NSC instance via INetStack->if\_receive() ).
- **INetStreamSocket** This is the structure defining a particular connection endpoint (file descriptor). It contains methods to operate on this endpoint, e.g. connect, disconnect, accept, listen, send\_data/read\_data, ...
- **InterruptCallback** This contains the wakeup callback, which is called by NSC whenever something of interest happens. Think of wakeup() as a replacement of the operating systems wakeup function: Whenever the operating system would wake up a process that has been waiting for an operation to complete (for example the TCP handshake during connect()), NSC invokes the wakeup() callback to allow the simulator to check for state changes in its connection endpoints.

## ns-3 implementation

The *ns-3* implementation makes use of the above NSC API, and is implemented as follows.

The three main parts are:

- `ns3::NscTcpL4Protocol`: a subclass of `Ipv4L4Protocol` (and two nsc classes: `ISendCallback` and `InterruptCallback`)
- `ns3::NscTcpSocketImpl`: a subclass of `TcpSocket`
- `ns3::NscTcpSocketFactoryImpl`: a factory to create new NSC sockets

`src/internet/model/nsc-tcp-l4-protocol` is the main class. Upon Initialization, it loads an nsc network stack to use (via `dlopen()`). Each instance of this class may use a different stack. The stack (=shared library) to use is set using the `SetNscLibrary()` method (at this time its called indirectly via the internet stack helper). The nsc stack is then set up accordingly (timers etc). The `NscTcpL4Protocol::Receive()` function hands the packet it receives (must be a complete tcp/ip packet) to the nsc stack for further processing. To be able to send packets, this class implements the `nsc send_callback` method. This method is called by nsc whenever the nsc stack wishes to send a packet out to the network. Its arguments are a raw buffer, containing a complete TCP/IP packet, and a length value. This method therefore has to convert the raw data to a `Ptr<Packet>` usable by *ns-3*. In order to avoid various ipv4 header issues, the nsc ip header is not included. Instead, the tcp header and the actual payload are put into the `Ptr<Packet>`, after this the

Packet is passed down to layer 3 for sending the packet out (no further special treatment is needed in the send code path).

This class calls `ns3::NscTcpSocketImpl` both from the `nsc wakeup()` callback and from the Receive path (to ensure that possibly queued data is scheduled for sending).

`src/internet/model/nsc-tcp-socket-impl` implements the `nsc` socket interface. Each instance has its own `nscTcpSocket`. Data that is `Send()` will be handed to the `nsc` stack via `m_nscTcpSocket->send_data()`. (and not to `nsc-tcp-l4`, this is the major difference compared to *ns-3* TCP). The class also queues up data that is `Send()` before the underlying descriptor has entered an ESTABLISHED state. This class is called from the `nsc-tcp-l4` class, when the `nsc-tcp-l4 wakeup()` callback is invoked by `nsc`. `nsc-tcp-socket-impl` then checks the current connection state (SYN\_SENT, ESTABLISHED, LISTEN...) and schedules appropriate callbacks as needed, e.g. a LISTEN socket will schedule `Accept` to see if a new connection must be accepted, an ESTABLISHED socket schedules any pending data for writing, schedule a read callback, etc.

Note that `ns3::NscTcpSocketImpl` does not interact with `nsc-tcp` directly: instead, data is redirected to `nsc`. `nsc-tcp` calls the `nsc-tcp-sockets` of a node when its `wakeup` callback is invoked by `nsc`.

## Limitations

- NSC only works on single-interface nodes; attempting to run it on a multi-interface node will cause a program error.
- Cygwin and OS X PPC are not supported
- The non-Linux stacks of NSC are not supported in *ns-3*
- Not all socket API callbacks are supported

For more information, see [this wiki page](#).





# LTE MODULE

## 16.1 Design Documentation

### 16.1.1 Overall Architecture

The overall architecture of the LENA simulation model is depicted in the figure *Overall architecture of the LTE-EPC simulation model*. There are two main components:

- the LTE Model. This model includes the LTE Radio Protocol stack (RRC, PDCP, RLC, MAC, PHY). These entities reside entirely within the UE and the eNB nodes.
- the EPC Model. This models includes core network interfaces, protocols and entities. These entities and protocols reside within the SGW, PGW and MME nodes, and partially within the eNB nodes.

Each component of the overall architecture is explained in detail in the following subsections.

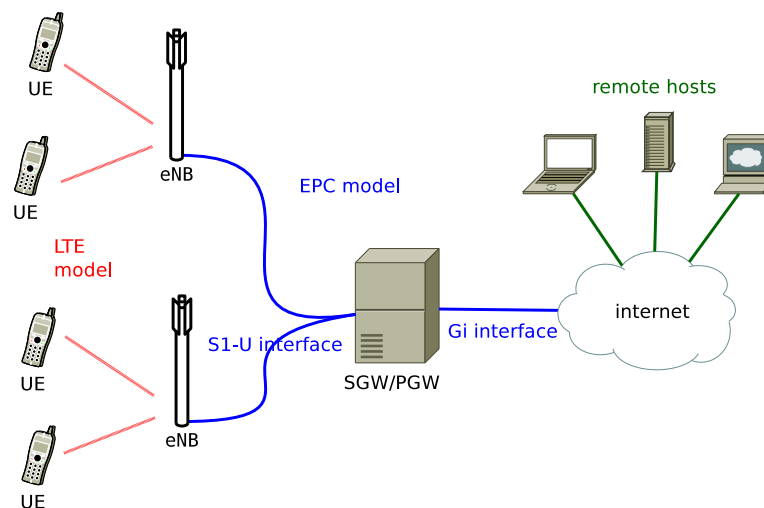

Figure 16.1: Overall architecture of the LTE-EPC simulation model

## 16.1.2 LTE Model

### Design Criteria

The LTE model has been designed to support the evaluation of the following aspects of LTE systems:

- Radio Resource Management
- QoS-aware Packet Scheduling
- Inter-cell Interference Coordination
- Dynamic Spectrum Access

In order to model LTE systems to a level of detail that is sufficient to allow a correct evaluation of the above mentioned aspects, the following requirements have been considered:

1. At the radio level, the granularity of the model should be at least that of the Resource Block (RB). In fact, this is the fundamental unit being used for resource allocation. Without this minimum level of granularity, it is not possible to model accurately packet scheduling and inter-cell-interference. The reason is that, since packet scheduling is done on a per-RB basis, an eNB might transmit on a subset only of all the available RBs, hence interfering with other eNBs only on those RBs where it is transmitting. Note that this requirement rules out the adoption of a system level simulation approach, which evaluates resource allocation only at the granularity of call/bearer establishment.
2. The simulator should scale up to tens of eNBs and hundreds of User Equipments (UEs). This rules out the use of a link level simulator, i.e., a simulator whose radio interface is modeled with a granularity up to the symbol level. This is because to have a symbol level model it is necessary to implement all the PHY layer signal processing, whose huge computational complexity severely limits simulation. In fact, link-level simulators are normally limited to a single eNB and one or a few UEs.
3. It should be possible within the simulation to configure different cells so that they use different carrier frequencies and system bandwidths. The bandwidth used by different cells should be allowed to overlap, in order to support dynamic spectrum licensing solutions such as those described in [Ofcom2600MHz] and [RealWireless]. The calculation of interference should handle appropriately this case.
4. To be more representative of the LTE standard, as well as to be as close as possible to real-world implementations, the simulator should support the MAC Scheduler API published by the FemtoForum [FFAPI]. This interface is expected to be used by femtocell manufacturers for the implementation of scheduling and Radio Resource Management (RRM) algorithms. By introducing support for this interface in the simulator, we make it possible for LTE equipment vendors and operators to test in a simulative environment exactly the same algorithms that would be deployed in a real system.
5. The LTE simulation model should contain its own implementation of the API defined in [FFAPI]. Neither binary nor data structure compatibility with vendor-specific implementations of the same interface are expected; hence, a compatibility layer should be interposed whenever a vendor-specific MAC scheduler is to be used with the simulator. This requirement is necessary to allow the simulator to be independent from vendor-specific implementations of this interface specification. We note that [FFAPI] is a logical specification only, and its implementation (e.g., translation to some specific programming language) is left to the vendors.
6. The model is to be used to simulate the transmission of IP packets by the upper layers. With this respect, it shall be considered that in LTE the Scheduling and Radio Resource Management do not work with IP packets directly, but rather with RLC PDUs, which are obtained by segmentation and concatenation of IP packets done by the RLC entities. Hence, these functionalities of the RLC layer should be modeled accurately.

### Architecture

For the sake of an easier explanation, we further divide the LTE model in two separate parts, which are described in the following.

The overall architecture of the LTE module is represented in the following figures.

The first part is the lower LTE radio protocol stack, which is represented in the figures *Lower LTE radio protocol stack architecture for the eNB* and *Lower LTE radio protocol stack architecture for the UE*, which deal respectively with the eNB and the UE.

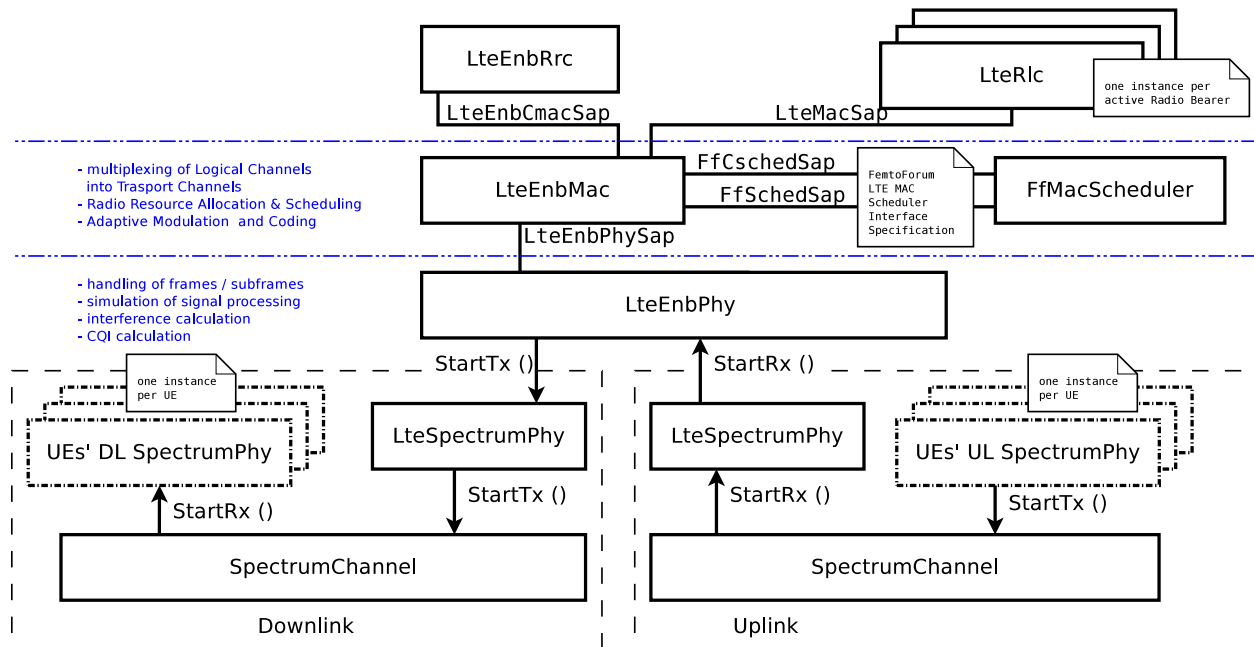

Figure 16.2: Lower LTE radio protocol stack architecture for the eNB

The LTE lower radio stack model includes in particular the PHY and the MAC layers; additionally, also the Scheduler is included (which is commonly associated with the MAC layer). The most important difference between the eNB and the UE is the presence of the Scheduler in the eNB, which is in charge of assigning radio resources to all UEs and Radio Bearers both in uplink and downlink. This component is not present within the UE.

The second part is the upper LTE radio stack, which is represented in the figure *Architecture of the upper LTE radio stack*.

This part includes the RRC, PDCP and RLC protocols. The architecture is very similar between the eNB and the UE: in fact, in both cases there is a single MAC instance and a single RRC instance, that work together with pairs of RLC and PDCP instances (one RLC and one PDCP instance per radio bearer).

We note that in the current version of the simulator the data plane of the upper LTE radio protocol stack is modeled accurately; in particular, the RLC and PDCP protocol are implemented with actual protocol headers that match those specified by the 3GPP standard. On the other hand, the functionality of the control plane (which for the upper LTE radio protocol stack involves mainly the RRC) is modeled in a significantly simplified fashion.

### 16.1.3 EPC Model

The EPC model provides means for the simulation of end-to-end IP connectivity over the LTE model. In particular, it supports for the interconnection of multiple UEs to the internet, via a radio access network of multiple eNBs connected to a single SGW/PGW node. This network topology is depicted in Figure *Overall architecture of the LTE-EPC simulation model*.

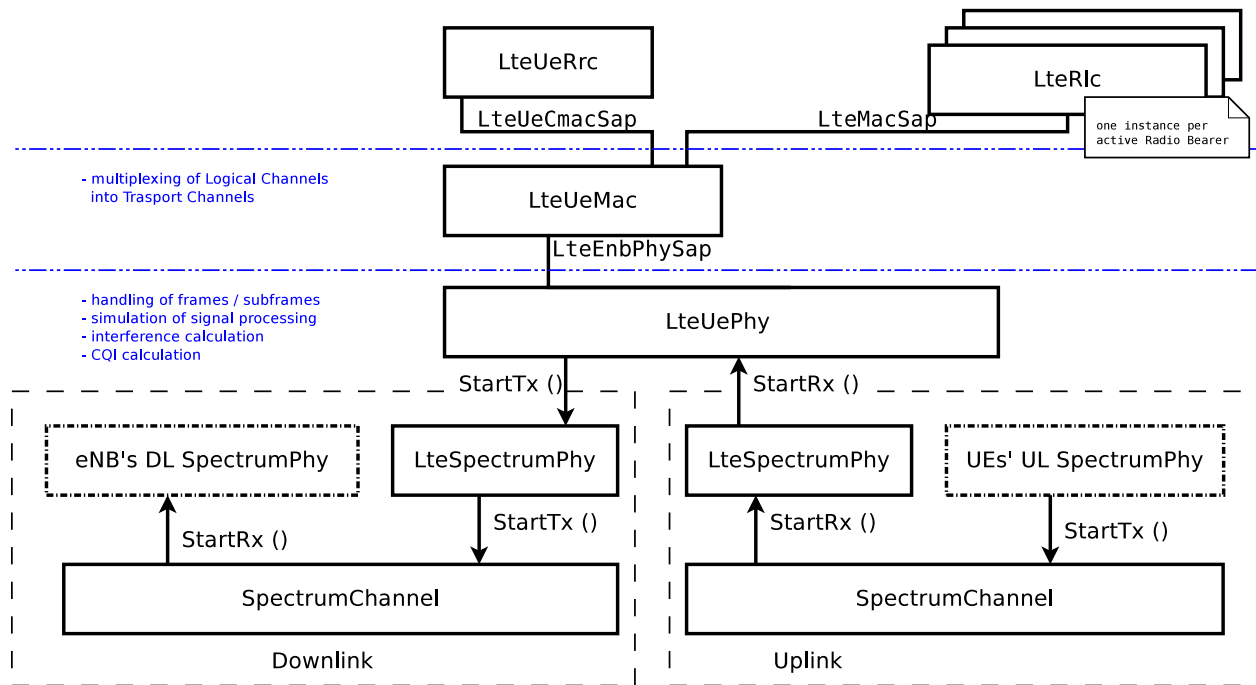

Figure 16.3: Lower LTE radio protocol stack architecture for the UE

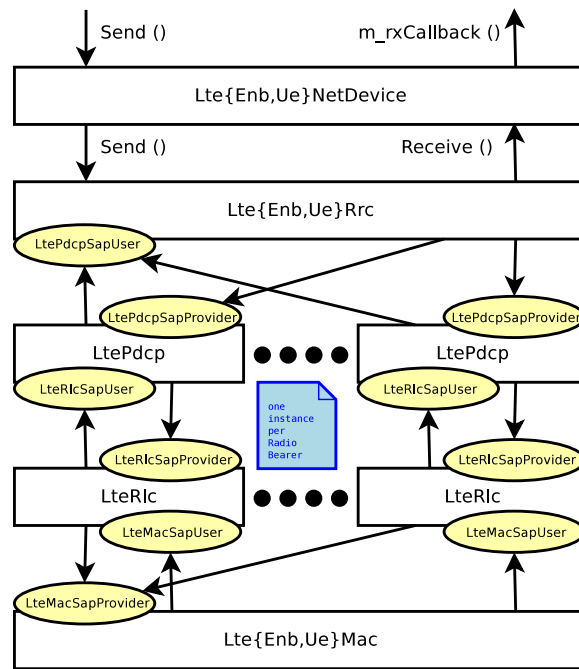

Figure 16.4: Architecture of the upper LTE radio stack

## Design Criteria

The following design choices have been made for the EPC model:

1. The only Packet Data Network (PDN) type supported is IPv4.
2. The SGW and PGW functional entities are implemented within a single node, which is hence referred to as the SGW/PGW node.
3. The scenarios with inter-SGW mobility are not of interests. Hence, a single SGW/PGW node will be present in all simulations scenarios
4. A requirement for the EPC model is that it can be used to simulate the end-to-end performance of realistic applications. Hence, it should be possible to use with the EPC model any regular ns-3 application working on top of TCP or UDP.
5. Another requirement is the possibility of simulating network topologies with the presence of multiple eNBs, some of which might be equipped with a backhaul connection with limited capabilities. In order to simulate such scenarios, the user data plane protocols being used between the eNBs and the SGW/PGW should be modeled accurately.
6. It should be possible for a single UE to use different applications with different QoS profiles. Hence, multiple EPS bearers should be supported for each UE. This includes the necessary classification of TCP/UDP traffic over IP done at the UE in the uplink and at the PGW in the downlink.
7. The focus of the EPC model is mainly on the EPC data plane. The accurate modeling of the EPC control plane is, for the time being, not a requirement; hence, the necessary control plane interactions can be modeled in a simplified way by leveraging on direct interaction among the different simulation objects via the provided helper objects.
8. The focus of the EPC model is on simulations of active users in ECM connected mode. Hence, all the functionality that is only relevant for ECM idle mode (in particular, tracking area update and paging) are not modeled at all.
9. While handover support is not a current requirement, it is planned to be considered in the near future. Hence, the management of EPS bearers by the eNBs and the SGW/PGW should be implemented in such a way that it can be re-used when handover support is eventually added.

## Architecture

The focus of the EPC model is currently on the EPC data plane. To understand the architecture of this model, we first look at Figure *LTE-EPC data plane protocol stack*, where we represent the end-to-end LTE-EPC protocol stack as it is implemented in the simulator. From the figure, it is evident that the biggest simplification introduced in the EPC model for the data plane is the inclusion of the SGW and PGW functionality within a single SGW/PGW node, which removes the need for the S5 or S8 interfaces specified by 3GPP. On the other hand, for both the S1-U protocol stack and the LTE radio protocol stack all the protocol layers specified by 3GPP are present.

As shown in the figure, there are two different layers of IP networking. The first one is the end-to-end layer, which provides end-to-end connectivity to the users; this layer involves the UEs, the PGW and the remote host (including eventual internet routers and hosts in between), but does not involve the eNB. By default, UEs are assigned a public IPv4 address in the 7.0.0.0/8 network, and the PGW gets the address 7.0.0.1, which is used by all UEs as the gateway to reach the internet.

The second layer of IP networking is the EPC local area network. This involves all eNB nodes and the SGW/PGW node. This network is implemented as a set of point-to-point links which connect each eNB with the SGW/PGW node; thus, the SGW/PGW has a set of point-to-point devices, each providing connectivity to a different eNB. By default, a 10.x.y.z/30 subnet is assigned to each point-to-point link (a /30 subnet is the smallest subnet that allows for two distinct host addresses).

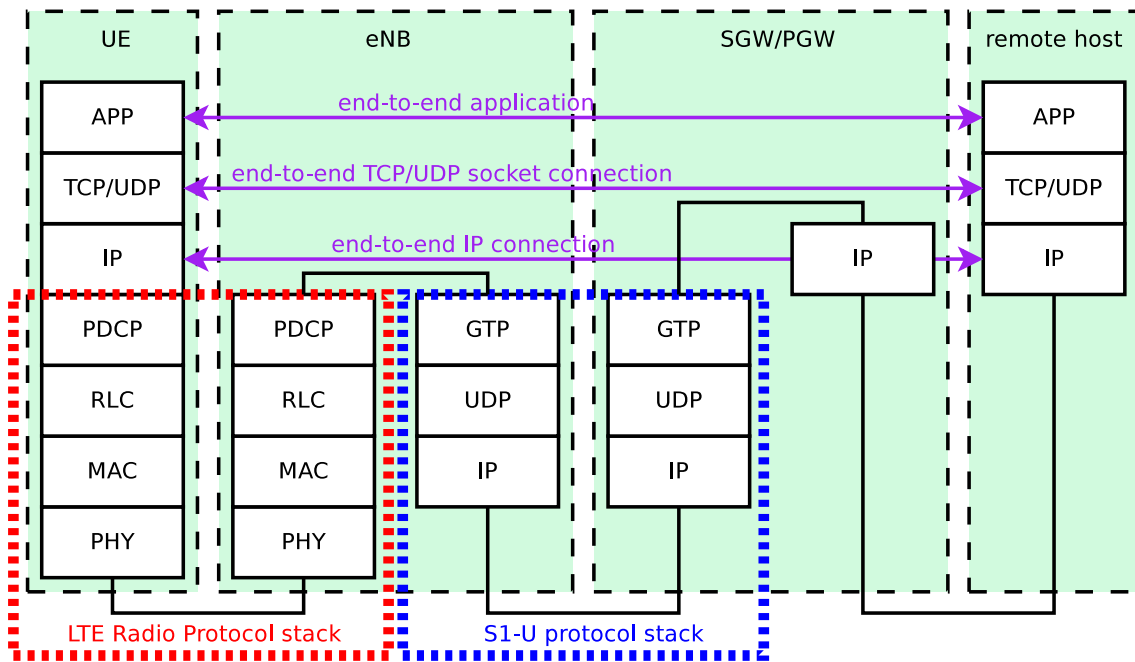

Figure 16.5: LTE-EPC data plane protocol stack

As specified by 3GPP, the end-to-end IP communications is tunneled over the local EPC IP network using GTP/UDP/IP. In the following, we explain how this tunneling is implemented in the EPC model. The explanation is done by discussing the end-to-end flow of data packets.

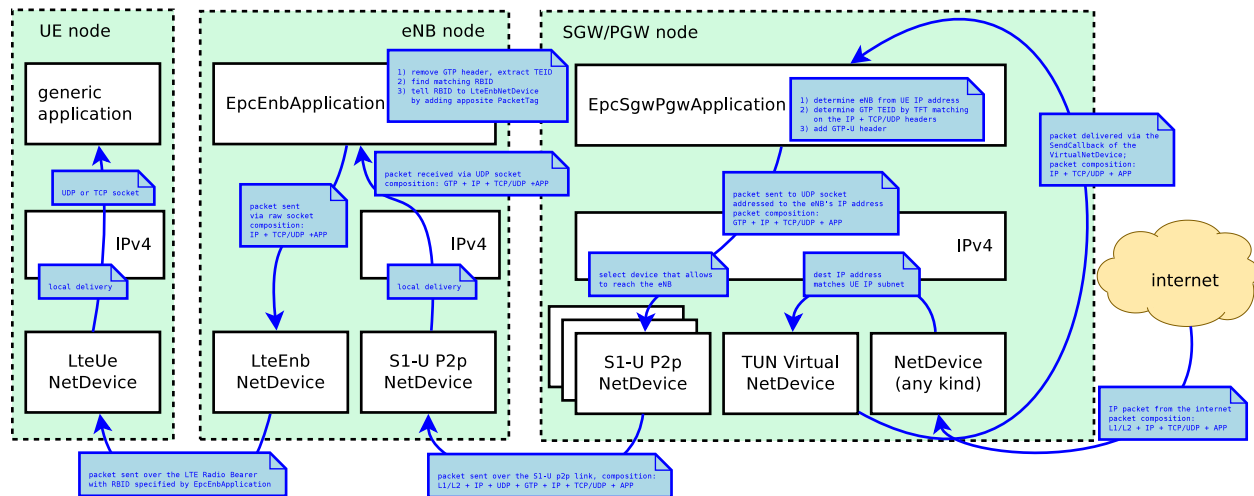

Figure 16.6: Data flow in the downlink between the internet and the UE

To begin with, we consider the case of the downlink, which is depicted in Figure *Data flow in the downlink between the internet and the UE*. Downlink IPv4 packets are generated from a generic remote host, and addressed to one of the UE device. Internet routing will take care of forwarding the packet to the generic NetDevice of the SGW/PGW node which is connected to the internet (this is the Gi interface according to 3GPP terminology). The SGW/PGW has a VirtualNetDevice which is assigned the gateway IP address of the UE subnet; hence, static routing rules will cause the incoming packet from the internet to be routed through this VirtualNetDevice. Such device starts the GTP/UDP/IP tunneling procedure, by forwarding the packet to a dedicated application in the SGW/PGW node which is called

EpcSgwPgwApplication. This application does the following operations:

1. it determines the eNB node to which the UE is attached, by looking at the IP destination address (which is the address of the UE);
2. it classifies the packet using Traffic Flow Templates (TFTs) to identify to which EPS Bearer it belongs. EPS bearers have a one-to-one mapping to S1-U Bearers, so this operation returns the GTP-U Tunnel Endpoint Identifier (TEID) to which the packet belongs;
3. it adds the corresponding GTP-U protocol header to the packet;
4. finally, it sends the packet over an UDP socket to the S1-U point-to-point NetDevice, addressed to the eNB to which the UE is attached.

As a consequence, the end-to-end IP packet with newly added IP, UDP and GTP headers is sent through one of the S1 links to the eNB, where it is received and delivered locally (as the destination address of the outmost IP header matches the eNB IP address). The local delivery process will forward the packet, via an UDP socket, to a dedicated application called EpcEnbApplication. This application then performs the following operations:

1. it removes the GTP header and retrieves the TEID which is contained in it;
2. leveraging on the one-to-one mapping between S1-U bearers and Radio Bearers (which is a 3GPP requirement), it determines the Radio Bearer ID (RBID) to which the packet belongs;
3. it records the RBID in a dedicated tag called LteRadioBearerTag, which is added to the packet;
4. it forwards the packet to the LteEnbNetDevice of the eNB node via a raw packet socket

Note that, at this point, the outmost header of the packet is the end-to-end IP header, since the IP/UDP/GTP headers of the S1 protocol stack have already been stripped. Upon reception of the packet from the EpcEnbApplication, the LteEnbNetDevice will retrieve the RBID from the LteRadioBearerTag, and based on the RBID will determine the Radio Bearer instance (and the corresponding PDCP and RLC protocol instances) which are then used to forward the packet to the UE over the LTE radio interface. Finally, the LteUeNetDevice of the UE will receive the packet, and delivery it locally to the IP protocol stack, which will in turn delivery it to the application of the UE, which is the end point of the downlink communication.

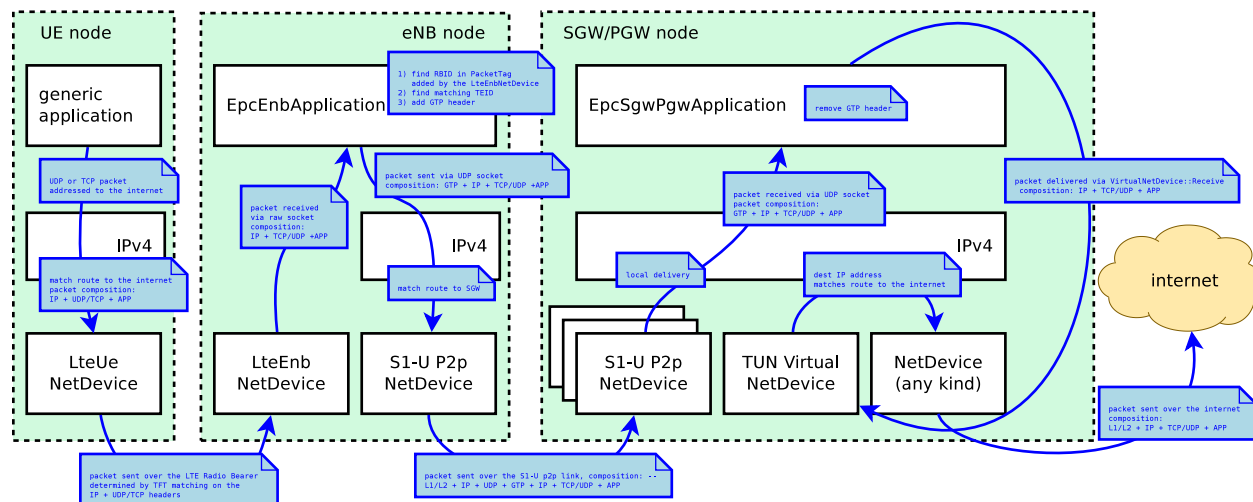

Figure 16.7: Data flow in the uplink between the UE and the internet

The case of the uplink is depicted in Figure *Data flow in the uplink between the UE and the internet*. Uplink IP packets are generated by a generic application inside the UE, and forwarded by the local TCP/IP stack to the LteUeNetDevice of the UE. The LteUeNetDevice then performs the following operations:

1. it classifies the packet using TFTs and determines the Radio Bearer to which the packet belongs (and the corresponding RBID);
2. it identifies the corresponding PDCP protocol instance, which is the entry point of the LTE Radio Protocol stack for this packet;
3. it sends the packet to the eNB over the LTE Radio Protocol stack.

The eNB receives the packet via its `LteEnbNetDevice`. Since there is a single PDCP and RLC protocol instance for each Radio Bearer, the `LteEnbNetDevice` is able to determine the RBID of the packet. This RBID is then recorded onto an `LteRadioBearerTag`, which is added to the packet. The `LteEnbNetDevice` then forwards the packet to the `EpcEnbApplication` via a raw packet socket.

Upon receiving the packet, the `EpcEnbApplication` performs the following operations:

1. it retrieves the RBID from the `LteRadioBearerTag` in the packet;
2. it determines the corresponding EPS Bearer instance and GTP-U TEID by leveraging on the one-to-one mapping between S1-U bearers and Radio Bearers;
3. it adds a GTP-U header on the packet, including the TEID determined previously;
4. it sends the packet to the SGW/PGW node via the UDP socket connected to the S1-U point-to-point net device.

At this point, the packet contains the S1-U IP, UDP and GTP headers in addition to the original end-to-end IP header. When the packet is received by the corresponding S1-U point-to-point `NetDevice` of the SGW/PGW node, it is delivered locally (as the destination address of the outmost IP header matches the address of the point-to-point net device). The local delivery process will forward the packet to the `EpcSgwPgwApplication` via the corresponding UDP socket. The `EpcSgwPgwApplication` then removes the GTP header and forwards the packet to the `VirtualNetDevice`. At this point, the outmost header of the packet is the end-to-end IP header. Hence, if the destination address within this header is a remote host on the internet, the packet is sent to the internet via the corresponding `NetDevice` of the SGW/PGW. In the event that the packet is addressed to another UE, the IP stack of the SGW/PGW will redirect the packet again to the `VirtualNetDevice`, and the packet will go through the downlink delivery process in order to reach its destination UE.

## 16.1.4 Detailed description of protocol elements

### MAC

#### The FemtoForum MAC Scheduler Interface

This section describes the ns-3 specific version of the LTE MAC Scheduler Interface Specification published by the FemtoForum [FFAPI].

We implemented the ns-3 specific version of the FemtoForum MAC Scheduler Interface [FFAPI] as a set of C++ abstract classes; in particular, each primitive is translated to a C++ method of a given class. The term *implemented* here is used with the same meaning adopted in [FFAPI], and hence refers to the process of translating the logical interface specification to a particular programming language. The primitives in [FFAPI] are grouped in two groups: the CSCHED primitives, which deal with scheduler configuration, and the SCHED primitives, which deal with the execution of the scheduler. Furthermore, [FFAPI] defines primitives of two different kinds: those of type REQ go from the MAC to the Scheduler, and those of type IND/CNF go from the scheduler to the MAC. To translate these characteristics into C++, we define the following abstract classes that implement Service Access Points (SAPs) to be used to issue the primitives:

- the `FfMacSchedSapProvider` class defines all the C++ methods that correspond to SCHED primitives of type REQ;
- the `FfMacSchedSapUser` class defines all the C++ methods that correspond to SCHED primitives of type CNF/IND;



- the `FfMacCschedSapProvider` class defines all the C++ methods that correspond to CSCHED primitives of type REQ;
- the `FfMacCschedSapUser` class defines all the C++ methods that correspond to CSCHED primitives of type CNF/IND;

There are 3 blocks involved in the MAC Scheduler interface: Control block, Subframe block and Scheduler block. Each of these blocks provide one part of the MAC Scheduler interface. The figure below shows the relationship between the blocks and the SAPs defined in our implementation of the MAC Scheduler Interface.

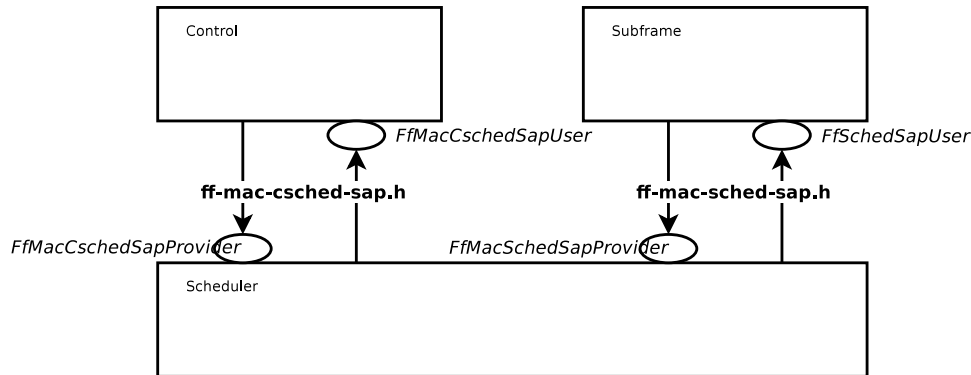

In addition to the above principles, the following design choices have been taken:

- The definition of the MAC Scheduler interface classes follows the naming conventions of the *ns-3* Coding Style. In particular, we follow the CamelCase convention for the primitive names. For example, the primitive `CSCHED_CELL_CONFIG_REQ` is translated to `CschedCellConfigReq` in the *ns-3* code.
- The same naming conventions are followed for the primitive parameters. As the primitive parameters are member variables of classes, they are also prefixed with a `m_`.
- regarding the use of vectors and lists in data structures, we note that [FFAPI] is a pretty much C-oriented API. However, considered that C++ is used in *ns-3*, and that the use of C arrays is discouraged, we used STL vectors (`std::vector`) for the implementation of the MAC Scheduler Interface, instead of using C arrays as implicitly suggested by the way [FFAPI] is written.
- In C++, members with constructors and destructors are not allow in unions. Hence all those data structures that are said to be unions in [FFAPI] have been defined as structs in our code.

The figure below shows how the MAC Scheduler Interface is used within the eNB.

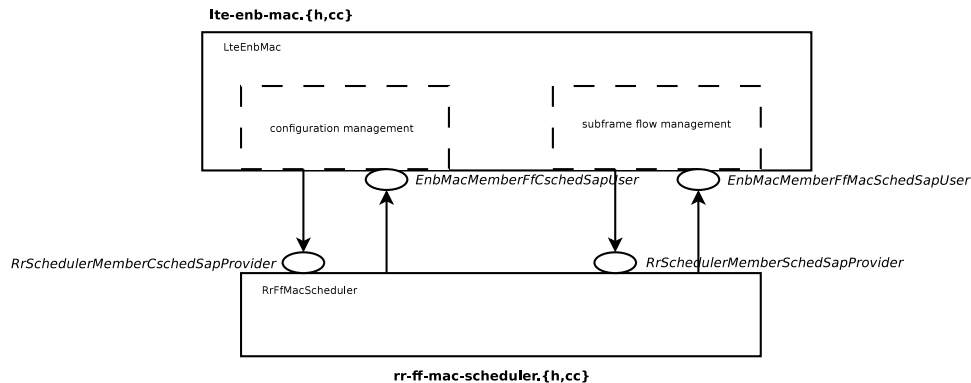

The User side of both the CSCHED SAP and the SCHED SAP are implemented within the eNB MAC, i.e., in the file `lte-enb-mac.cc`. The eNB MAC can be used with different scheduler implementations without modifications.

The same figure also shows, as an example, how the Round Robin Scheduler is implemented: to interact with the MAC of the eNB, the Round Robin scheduler implements the Provider side of the SCHED SAP and CSCHED SAP interfaces. A similar approach can be used to implement other schedulers as well. A description of all the scheduler implementations that we provide as part of our LTE simulation module will be given in the following.

### Resource Allocation Model

We now briefly describe how resource allocation is handled in LTE, clarifying how it is implemented in the simulator. The scheduler is in charge of generating specific structures called Data Control Indication (DCI) which are then transmitted by the PHY of the eNB to the connected UEs, in order to inform them of the resource allocation on a per subframe basis. In doing this in the downlink direction, the scheduler has to fill some specific fields of the DCI structure with all the information, such as: the Modulation and Coding Scheme (MCS) to be used, the MAC Transport Block (TB) size, and the allocation bitmap which identifies which RBs will contain the data transmitted by the eNB to each user.

For the mapping of resources to physical RBs, we adopt a *localized mapping* approach (see [Sesia2009], Section 9.2.2.1); hence in a given subframe each RB is always allocated to the same user in both slots. The allocation bitmap can be coded in different formats; in this implementation, we considered the *Allocation Type 0* defined in [TS36213], according to which the RBs are grouped in Resource Block Groups (RBG) of different size determined as a function of the Transmission Bandwidth Configuration in use.

For certain bandwidth values not all the RBs are usable, since the group size is not a common divisor of the group. This is for instance the case when the bandwidth is equal to 25 RBs, which results in a RBG size of 2 RBs, and therefore 1 RB will result not addressable. In uplink the format of the DCIs is different, since only adjacent RBs can be used because of the SC-FDMA modulation. As a consequence, all RBs can be allocated by the eNB regardless of the bandwidth configuration.

### Adaptive Modulation and Coding

The simulator provides two Adaptive Modulation and Coding (AMC) models: one based on the GSoC model [Piro2011] and one based on the physical error model (described in the following sections).

The former model is a modified version of the model described in [Piro2011], which in turn is inspired from [Seo2004]. Our version is described in the following. Let  $i$  denote the generic user, and let  $\gamma_i$  be its SINR. We get the spectral efficiency  $\eta_i$  of user  $i$  using the following equations:

$$\begin{aligned} \text{BER} &= 0.00005 \\ \Gamma &= \frac{-\ln(5 * \text{BER})}{1.5} \\ \eta_i &= \log_2 \left( 1 + \frac{\gamma_i}{\Gamma} \right) \end{aligned}$$

The procedure described in [R1-081483] is used to get the corresponding MCS scheme. The spectral efficiency is quantized based on the channel quality indicator (CQI), rounding to the lowest value, and is mapped to the corresponding MCS scheme.

Finally, we note that there are some discrepancies between the MCS index in [R1-081483] and that indicated by the standard: [TS36213] Table 7.1.7.1-1 says that the MCS index goes from 0 to 31, and 0 appears to be a valid MCS scheme (TB size is not 0) but in [R1-081483] the first useful MCS index is 1. Hence to get the value as intended by the standard we need to subtract 1 from the index reported in [R1-081483].

The alternative model is based on the physical error model developed for this simulator and explained in the following subsections. This scheme is able to adapt the MCS selection to the actual PHY layer performance according to the specific CQI report. According to their definition, a CQI index is assigned when a single PDSCH TB with the modulation coding scheme and code rate correspondent to that CQI index in table 7.2.3-1 of [TS36213] can be received

with an error probability less than 0.1. In case of wideband CQIs, the reference TB includes all the RBGs available in order to have a reference based on the whole available resources; while, for subband CQIs, the reference TB is sized as the RBGs.

### Round Robin (RR) Scheduler

The Round Robin (RR) scheduler is probably the simplest scheduler found in the literature. It works by dividing the available resources among the active flows, i.e., those logical channels which have a non-empty RLC queue. If the number of RBGs is greater than the number of active flows, all the flows can be allocated in the same subframe. Otherwise, if the number of active flows is greater than the number of RBGs, not all the flows can be scheduled in a given subframe; then, in the next subframe the allocation will start from the last flow that was not allocated. The MCS to be adopted for each user is done according to the received wideband CQIs.

### Proportional Fair (PF) Scheduler

The Proportional Fair (PF) scheduler [Sesia2009] works by scheduling a user when its instantaneous channel quality is high relative to its own average channel condition over time. Let  $i, j$  denote generic users; let  $t$  be the subframe index, and  $k$  be the resource block index; let  $M_{i,k}(t)$  be MCS usable by user  $i$  on resource block  $k$  according to what reported by the AMC model (see [Adaptive Modulation and Coding](#)); finally, let  $S(M, B)$  be the TB size in bits as defined in [TS36213] for the case where a number  $B$  of resource blocks is used. The achievable rate  $R_i(k, t)$  in bit/s for user  $i$  on resource block group  $k$  at subframe  $t$  is defined as

$$R_i(k, t) = \frac{S(M_{i,k}(t), 1)}{\tau}$$

where  $\tau$  is the TTI duration. At the start of each subframe  $t$ , each RBG is assigned to a certain user. In detail, the index  $\hat{i}_k(t)$  to which RBG  $k$  is assigned at time  $t$  is determined as

$$\hat{i}_k(t) = \operatorname{argmax}_{j=1, \dots, N} \left( \frac{R_j(k, t)}{T_j(t)} \right)$$

where  $T_j(t)$  is the past throughput performance perceived by the user  $j$ . According to the above scheduling algorithm, a user can be allocated to different RBGs, which can be either adjacent or not, depending on the current condition of the channel and the past throughput performance  $T_j(t)$ . The latter is determined at the end of the subframe  $t$  using the following exponential moving average approach:

$$T_j(t) = \left(1 - \frac{1}{\alpha}\right)T_j(t-1) + \frac{1}{\alpha}\hat{T}_j(t)$$

where  $\alpha$  is the time constant (in number of subframes) of the exponential moving average, and  $\hat{T}_j(t)$  is the actual throughput achieved by the user  $i$  in the subframe  $t$ .  $\hat{T}_j(t)$  is measured according to the following procedure. First we determine the MCS  $\widehat{M}_j(t)$  actually used by user  $j$ :

$$\widehat{M}_j(t) = \min_{k: \hat{i}_k(t)=j} M_{j,k}(t)$$

then we determine the total number  $\widehat{B}_j(t)$  of RBGs allocated to user  $j$ :

$$\widehat{B}_j(t) = \left| \{k : \hat{i}_k(t) = j\} \right|$$

where  $|\cdot|$  indicates the cardinality of the set; finally,

$$\widehat{T}_j(t) = \frac{S(\widehat{M}_j(t), \widehat{B}_j(t))}{\tau}$$

## Transport Blocks

The implementation of the MAC Transport Blocks (TBs) is simplified with respect to the 3GPP specifications. In particular, a simulator-specific class (PacketBurst) is used to aggregate MAC SDUs in order to achieve the simulator's equivalent of a TB, without the corresponding implementation complexity. The multiplexing of different logical channels to and from the RLC layer is performed using a dedicated packet tag (LteRadioBearerTag), which performs a functionality which is partially equivalent to that of the MAC headers specified by 3GPP.

## RLC and PDCP

### Overview

The RLC entity is specified in the 3GPP technical specification [TS36322], and comprises three different types of RLC: Transparent Mode (TM), Unacknowledge Mode (UM) and Acknowledged Mode (AM). We implement only the UM and the AM RLC entities.

The RLC entities provide the RLC service interface to the upper PDCP layer and the MAC service interface to the lower MAC layer. The RLC entities use the PDCP service interface from the upper PDCP layer and the MAC service interface from the lower MAC layer.

Figure *Implementation Model of PDCP, RLC and MAC entities and SAPs* shows the implementation model of the RLC entities and its relationship with all the other entities and services in the protocol stack.

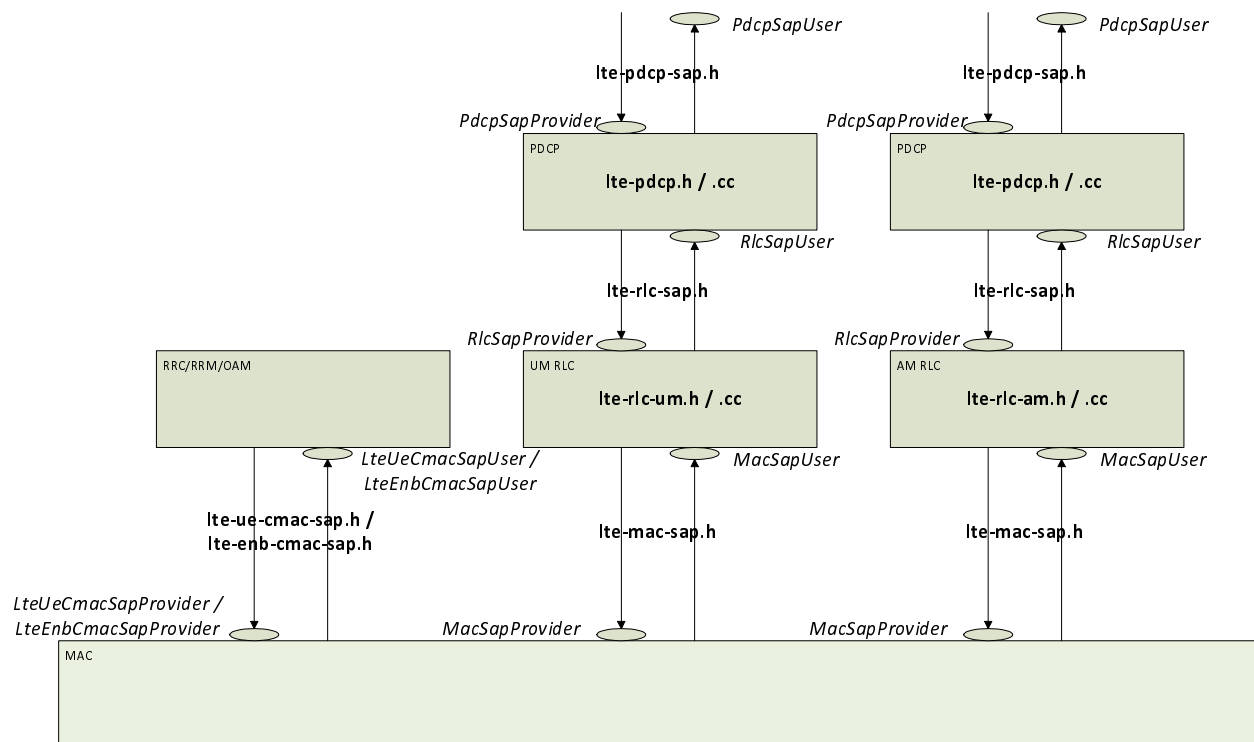

Figure 16.8: Implementation Model of PDCP, RLC and MAC entities and SAPs

### Service Interfaces

**PDCP Service Interface** The PDCP service interface is divided into two parts:

- the `PdcpSapProvider` part is provided by the PDCP layer and used by the upper layer and
- the `PdcpSapUser` part is provided by the upper layer and used by the PDCP layer.

**PDCP Service Primitives** The following list specifies which service primitives are provided by the PDCP service interfaces:

- `PdcpSapProvider::TransmitRrcPdu`
  - The RRC entity uses this primitive to send an RRC PDU to the lower PDCP entity in the transmitter peer
- `PdcpSapUser::ReceiveRrcPdu`
  - The PDCP entity uses this primitive to send an RRC PDU to the upper RRC entity in the receiver peer

**RLC Service Interface** The RLC service interface is divided into two parts:

- the `RlcSapProvider` part is provided by the RLC layer and used by the upper PDCP layer and
- the `RlcSapUser` part is provided by the upper PDCP layer and used by the RLC layer.

Both the UM and the AM RLC entities provide the same RLC service interface to the upper PDCP layer.

**RLC Service Primitives** The following list specifies which service primitives are provided by the RLC service interfaces:

- `RlcSapProvider::TransmitPdcPdu`
  - The PDCP entity uses this primitive to send a PDCP PDU to the lower RLC entity in the transmitter peer
- `RlcSapUser::ReceivePdcPdu`
  - The RLC entity uses this primitive to send a PDCP PDU to the upper PDCP entity in the receiver peer

**MAC Service Interface** The MAC service interface is divided into two parts:

- the `MacSapProvider` part is provided by the MAC layer and used by the upper RLC layer and
- the `MacSapUser` part is provided by the upper RLC layer and used by the MAC layer.

**MAC Service Primitives** The following list specifies which service primitives are provided by the MAC service interfaces:

- `MacSapProvider::TransmitPdu`
  - The RLC entity uses this primitive to send a RLC PDU to the lower MAC entity in the transmitter peer
- `MacSapProvider::ReportBufferStatus`
  - The RLC entity uses this primitive to report the MAC entity the size of pending buffers in the transmitter peer
- `MacSapUser::NotifyTxOpportunity`
  - The MAC entity uses this primitive to notify the RLC entity a transmission opportunity
- `MacSapUser::ReceivePdu`
  - The MAC entity uses this primitive to send an RLC PDU to the upper RLC entity in the receiver peer

## Interactions between entities and services

**Transmit operations in downlink** The following sequence diagram shows the interactions between the different entities (RRC, PDCP, AM RLC, MAC and MAC scheduler) of the eNB in the downlink to perform data communications.

Figure *Sequence diagram of data PDU transmission in downlink* shows how the upper layers send data PDUs and how the data flow is processed by the different entities/services of the LTE protocol stack. We will explain in detail only the processing related to the AM RLC entity, which is the most complex.

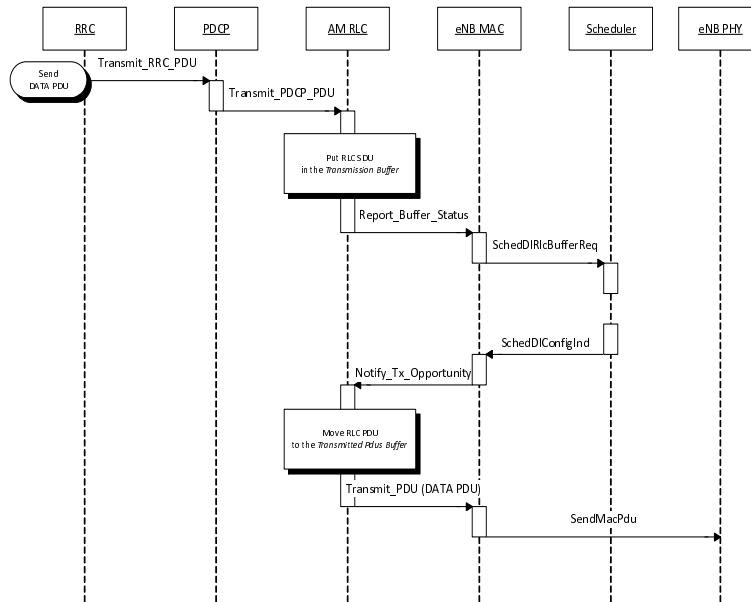

Figure 16.9: Sequence diagram of data PDU transmission in downlink

The PDCP entity calls the `Transmit_PDCP_PDU` service primitive in order to send a data PDU. The AM RLC entity processes this service primitive according to the AM data transfer procedures defined in section 5.1.3 of [TS36322].

When the `Transmit_PDCP_PDU` service primitive is called, the AM RLC entity performs the following operations:

- Put the data SDU in the Transmission Buffer.
- Compute the size of the buffers (how the size of buffers is computed will be explained afterwards).
- Call the `Report_Buffer_Status` service primitive of the eNB MAC entity in order to notify to the eNB MAC entity the sizes of the buffers of the AM RLC entity. Then, the eNB MAC entity updates the buffer status in the MAC scheduler using the `SchedDIRlcBufferReq` service primitive of the FF MAC Scheduler API.

Afterwards, when the MAC scheduler decides that some data can be sent, the MAC entity notifies it to the RLC entity, i.e. it calls the `Notify_Tx_Opportunity` service primitive, then the AM RLC entity does the following:

- Create a single data PDU by segmenting and/or concatenating the SDUs in the Transmission Buffer.
- Move the data PDU from the Transmission Buffer to the Transmitted PDUs Buffer.
- Update state variables according section 5.1.3.1.1 of [TS36322].
- Call the `Transmit_PDU` primitive in order to send the data PDU to the MAC entity.

**Retransmission in downlink** The sequence diagram of Figure *Sequence diagram of data PDU retransmission in downlink* shows the interactions between the different entities (AM RLC, MAC and MAC scheduler) of the eNB in downlink when data PDUs must be retransmitted by the AM RLC entity.

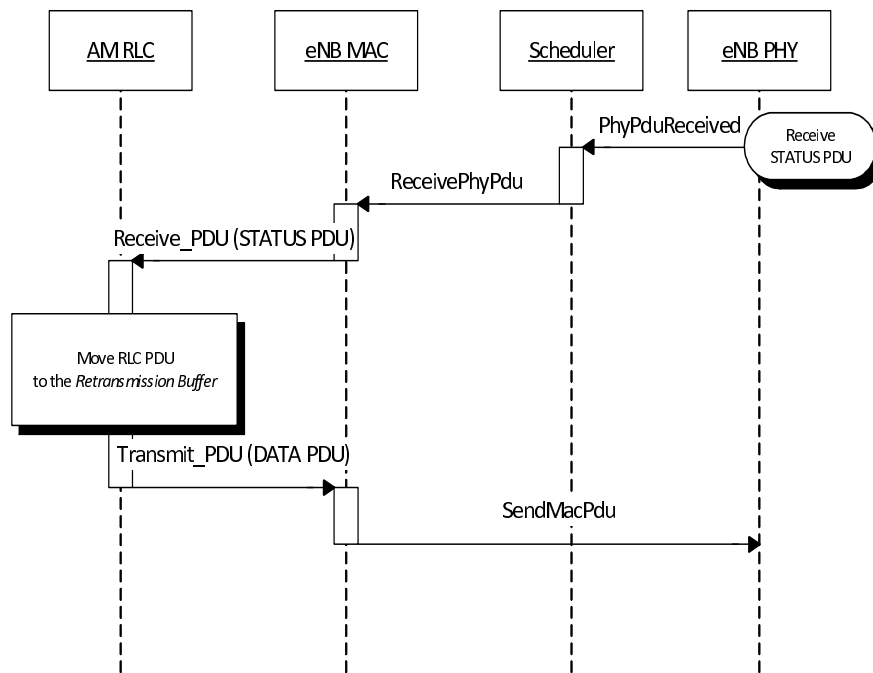

Figure 16.10: Sequence diagram of data PDU retransmission in downlink

The transmitting AM RLC entity can receive STATUS PDUs from the peer AM RLC entity. STATUS PDUs are sent according section 5.3.2 of [TS36322] and the processing of reception is made according section 5.2.1 of [TS36322].

When a data PDU is retransmitted from the Transmitted PDUs Buffer, it is also moved to the Retransmission Buffer.

**Transmit operations in uplink** The sequence diagram of Figure *Sequence diagram of data PDU transmission in uplink* shows the interactions between the different entities of the UE (RRC, PDCP, RLC and MAC) and the eNB (MAC and Scheduler) in uplink when data PDUs are sent by the upper layers.

It is similar to the sequence diagram in downlink; the main difference is that in this case the Report\_Buffer\_Status is sent from the UE MAC to the MAC Scheduler in the eNB over the air using the control channel.

**Retransmission in uplink** The sequence diagram of Figure *Sequence diagram of data PDU retransmission in uplink* shows the interactions between the different entities of the UE (AM RLC and MAC) and the eNB (MAC) in uplink when data PDUs must be retransmitted by the AM RLC entity.

### AM data transfer

The processing of the data transfer in the AM RLC entity is explained in section 5.1.3 of [TS36322]. In this section we describe some details of the implementation of the RLC entity.

**Management of buffers in transmit operations** The AM RLC entity manages 3 buffers:

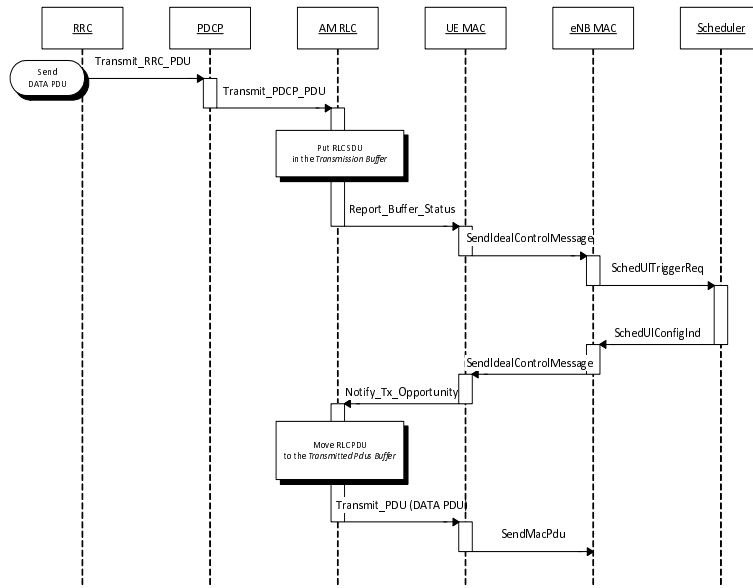

Figure 16.11: Sequence diagram of data PDU transmission in uplink

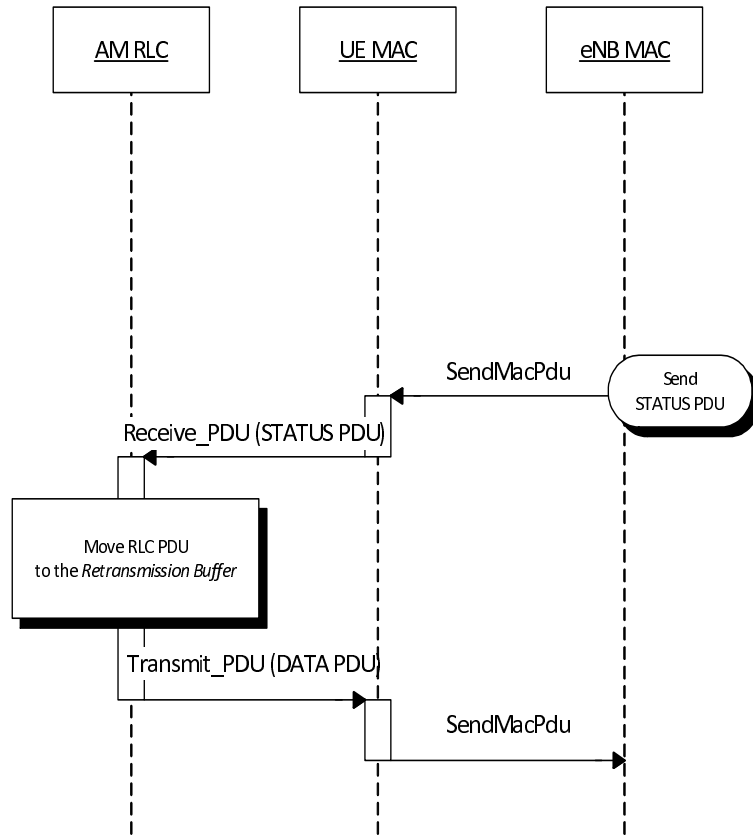

Figure 16.12: Sequence diagram of data PDU retransmission in uplink



- **Transmission Buffer:** it is the RLC SDU queue. When the AM RLC entity receives a SDU in the `TransmitPdcPdu` service primitive from the upper PDCP entity, it enqueues it in the Transmission Buffer. We put a limit on the RLC buffer size and just silently drop SDUs when the buffer is full.
- **Transmitted PDUs Buffer:** it is the queue of transmitted RLC PDUs for which an ACK/NACK has not been received yet. When the AM RLC entity sends a PDU to the MAC entity, it also puts a copy of the transmitted PDU in the Transmitted PDUs Buffer.
- **Retransmission Buffer:** it is the queue of RLC PDUs which are considered for retransmission (i.e., they have been NACKed). The AM RLC entity moves this PDU to the Retransmission Buffer, when it retransmits a PDU from the Transmitted Buffer.

**Calculation of the buffer size** The Transmission Buffer contains RLC SDUs. A RLC PDU is one or more SDU segments plus an RLC header. The size of the RLC header of one RLC PDU depends on the number of SDU segments the PDU contains.

The 3GPP standard (section 6.1.3.1 of [TS36321]) says clearly that, for the uplink, the RLC and MAC headers are not considered in the buffer size that is to be report as part of the Buffer Status Report. For the downlink, the behavior is not specified. Neither [FFAPI] specifies how to do it. Our RLC model works by assuming that the calculation of the buffer size in the downlink is done exactly as in the uplink, i.e., not considering the RLC and MAC header size.

We note that this choice affects the interoperation with the MAC scheduler, since, in response to the `NotifyTxOpportunity` service primitive, the RLC is expected to create a PDU of no more than the size requested by the MAC, including RLC overhead. Hence, unneeded fragmentation can occur if (for example) the MAC notifies a transmission exactly equal to the buffer size previously reported by the RLC. We assume that it is left to the Scheduler to implement smart strategies for the selection of the size of the transmission opportunity, in order to eventually avoid the inefficiency of unneeded fragmentation.

**Concatenation and Segmentation** The AM RLC entity generates and sends exactly one RLC PDU for each transmission opportunity even if it is smaller than the size reported by the transmission opportunity. So for instance, if a STATUS PDU is to be sent, then only this PDU will be sent in that transmission opportunity.

The segmentation and concatenation for the SDU queue of the AM RLC entity follows the same philosophy as the same procedures of the UM RLC entity but there are new state variables (see section 7.1) only present in the AM RLC entity.

It is noted that, according to the 3GPP specs, there is no concatenation for the Retransmission Buffer.

**Re-segmentation** The current model of the AM RLC entity does not support the re-segmentation of the retransmission buffer. Rather, the AM RLC entity just expects to receive a big enough transmission opportunity. An assertion fails if a too small transmission opportunity is received.

**Unsupported features** We do not support the following procedures of [TS36322] :

- “Send an indication of successful delivery of RLC SDU” (See section 5.1.3.1.1)
- “Indicate to upper layers that max retransmission has been reached” (See section 5.2.1)
- “SDU discard procedures” (See section 5.3)
- “Re-establishment procedure” (See section 5.4)

We do not support any of the additional primitives of RLC SAP for AM RLC entity. In particular:

- no SDU discard notified by PDCP
- no notification of successful / failed delivery by AM RLC entity to PDCP entity

## RLC/SM

In addition to the full-fledged RLC/UM and RLC/AM implementations, a simplified RLC model is provided, which is denoted RLC/SM. This RLC model does not accept PDUs from any above layer (such as PDCP); rather, RLC/SM takes care of the generation of RLC PDUs in response to the notification of transmission opportunities notified by the MAC. In other words, RLC/SM simulates saturation conditions, i.e., it assumes that the RLC buffer is always full and can generate a new PDU whenever notified by the scheduler. In fact, the “SM” in the name of the model stands for “Saturation Mode”.

RLC/SM is used for simplified simulation scenarios in which only the LTE Radio model is used, without the EPC and hence without any IP networking support. We note that, although RLC/SM is an unrealistic traffic model, it still allows for the correct simulation of scenarios with multiple flows belonging to different (non real-time) QoS classes, in order to test the QoS performance obtained by different schedulers. This can be done since it is the task of the Scheduler to assign transmission resources based on the characteristics of each Radio Bearer which are specified upon the creation of each Bearer at the start of the simulation.

As for schedulers designed to work with real-time QoS traffic that has delay constraints, RLC/SM is probably not an appropriate choice. This is because the absence of actual RLC SDUs (replaced by the artificial generation of Buffer Status Reports) makes it not possible to provide the Scheduler with meaningful head-of-line-delay information, which is normally the metric of choice for the implementation of scheduling policies for real-time traffic flows. For the simulation and testing of such schedulers, it is advisable to use one of the realistic RLC implementations (RLC/UM or RLC/AM).

## PDCP

The reference document for the specification of the PDCP entity is [TS36323]. With respect to this specification, the PDCP model implemented in the simulator supports only the following features:

- transfer of data (user plane or control plane);
- maintenance of PDCP SNs;

The following features are currently not supported:

- header compression and decompression of IP data flows using the ROHC protocol;
- in-sequence delivery of upper layer PDUs at re-establishment of lower layers;
- duplicate elimination of lower layer SDUs at re-establishment of lower layers for radio bearers mapped on RLC AM;
- ciphering and deciphering of user plane data and control plane data;
- integrity protection and integrity verification of control plane data;
- timer based discard;
- duplicate discarding.

## RRC

At the time of this writing, the RRC model implemented in the simulator is not comprehensive of all the functionalities defined by the 3GPP standard. In particular, RRC messaging over signaling radio bearer is not implemented; the corresponding control functionality is performed via direct function calls among the relevant eNB and UE protocol entities and the helper objects.

The RRC implements the procedures for managing the connection of the UEs to the eNBs, and to setup and release the Radio Bearers. The RRC entity also takes care of multiplexing data packets coming from the upper layers into

the appropriate radio bearer. In the UE, this is performed in the uplink by using the Traffic Flow Template classifier (TftClassifier). In the eNB, this is done for downlink traffic, by leveraging on the one-to-one mapping between S1-U bearers and Radio Bearers, which is required by the 3GPP specifications.

## PHY

### Overview

The physical layer model provided in this LTE simulator is based on the one described in [Piro2011], with the following modifications. The model now includes the inter cell interference calculation and the simulation of uplink traffic, including both packet transmission and CQI generation.

**MAC to Channel delay** To model the latency of real MAC and PHY implementations, the PHY model simulates a MAC-to-channel delay in multiples of TTIs (1ms). The transmission of both data and control packets are delayed by this amount.

**CQI feedback** The generation of CQI feedback is done accordingly to what specified in [FFAPI]. In detail, we considered the generation of periodic wideband CQI (i.e., a single value of channel state that is deemed representative of all RBs in use) and inband CQIs (i.e., a set of value representing the channel state for each RB).

The CQI feedbacks are currently evaluated according to the SINR perceived by data transmissions (i.e., PDSCH for downlink and PUSCH for uplink) instead of the one based on reference signals (i.e., RS for downlink and SRS for uplink) since that signals are not implemented in the current version of the PHY layer. This implies that a UE has to transmit some data in order to have CQI feedbacks. This assumption is based on the fact that the reference signals defined in LTE are usually multiplexed within the data transmissions resources.

**Interference Model** The PHY model is based on the well-known Gaussian interference models, according to which the powers of interfering signals (in linear units) are summed up together to determine the overall interference power.

The sequence diagram of Figure *Sequence diagram of the PHY interference calculation procedure* shows how interfering signals are processed to calculate the SINR, and how SINR is then used for the generation of CQI feedback.

**LTE Spectrum Model** The usage of the radio spectrum by eNBs and UEs in LTE is described in [TS36101]. In the simulator, radio spectrum usage is modeled as follows. Let  $f_c$  denote the LTE Absolute Radio Frequency Channel Number, which identifies the carrier frequency on a 100 kHz raster; furthermore, let  $B$  be the Transmission Bandwidth Configuration in number of Resource Blocks. For every pair  $(f_c, B)$  used in the simulation we define a corresponding spectrum model using the Spectrum framework described in [Baldo2009].  $f_c$  and  $B$  can be configured for every eNB instantiated in the simulation; hence, each eNB can use a different spectrum model. Every UE will automatically use the spectrum model of the eNB it is attached to. Using the MultiModelSpectrumChannel described in [Baldo2009], the interference among eNBs that use different spectrum models is properly accounted for. This allows to simulate dynamic spectrum access policies, such as for example the spectrum licensing policies that are discussed in [Ofcom2600MHz].

### PHY Error Model

The simulator includes an error model of the data plane (i.e., PDSCH) according to the standard link-to-system mapping (LSM) techniques. The choice is aligned with the standard system simulation methodology of OFDMA radio transmission technology. Thanks to LSM we are able to maintain a good level of accuracy and at the same time limiting the computational complexity increase. It is based on the mapping of single link layer performance obtained by

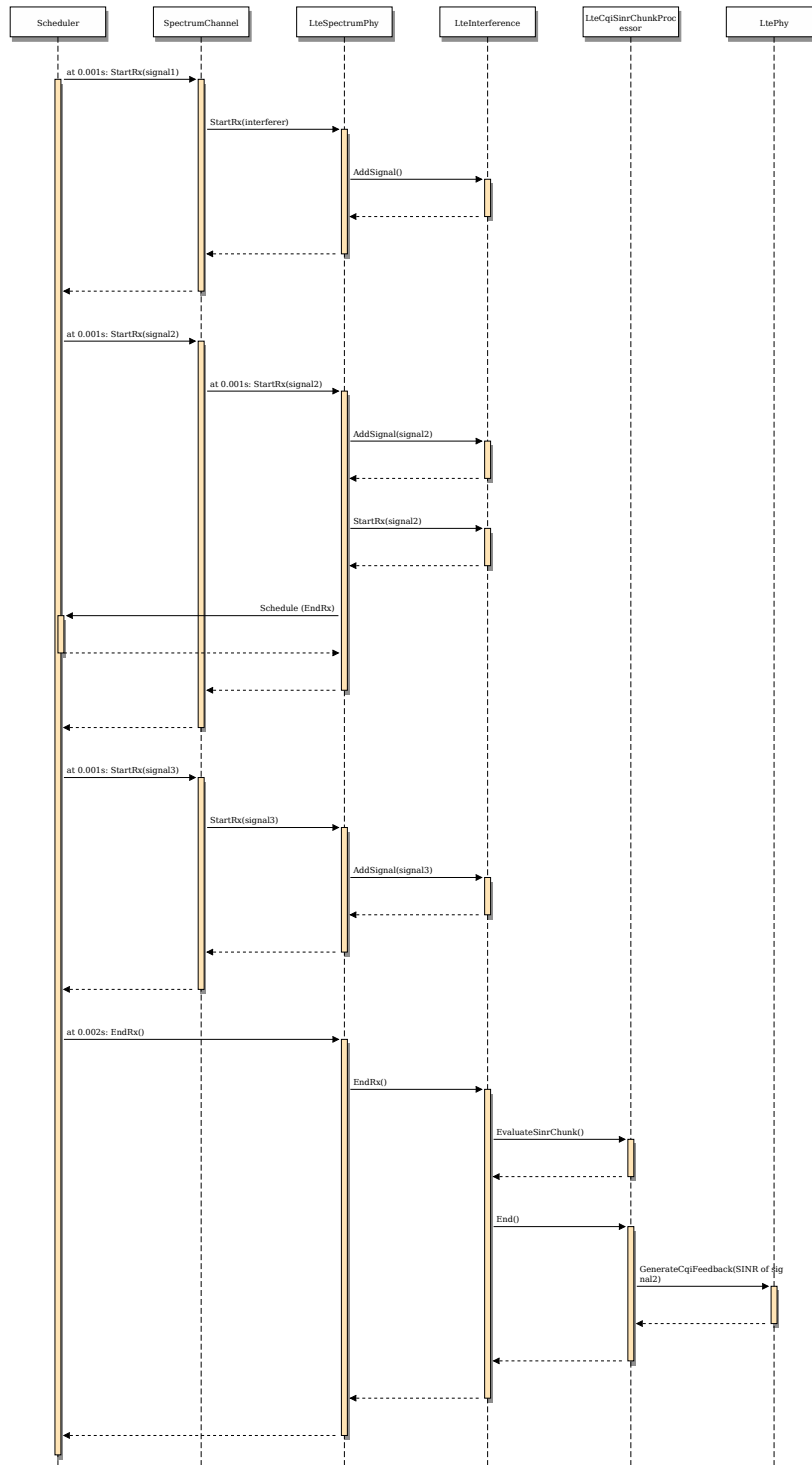

Figure 16.13: Sequence diagram of the PHY interference calculation procedure

means of link level simulators to system (in our case network) simulators. In particular link the layer simulator is used for generating the performance of a single link from a PHY layer perspective, usually in terms of code block error rate (BLER), under specific static conditions. LSM allows the usage of these parameters in more complex scenarios, typical of system/network simulators, where we have more links, interference and “colored” channel propagation phenomena (e.g., frequency selective fading).

To do this the Vienna LTE Simulator [ViennaLteSim] has been used for what concerns the extraction of link layer performance and the Mutual Information Based Effective SINR (MIESM) as LSM mapping function using part of the work recently published by the Signet Group of University of Padua [PaduaPEM].

**MIESM** The specific LSM method adopted is the one based on the usage of a mutual information metric, commonly referred to as the mutual information per per coded bit (MIB or MMIB when a mean of multiples MIBs is involved). Another option would be represented by the Exponential ESM (EESM); however, recent studies demonstrate that MIESM outperforms EESM in terms of accuracy [LozanoCost]. Moreover, from an HARQ perspective, the MIESM has more flexibility in managing the combinations of the HARQ blocks. In fact, by working in the MI field, the formulas for evaluating both the chase combining (CC) and the incremental redundancy (IR) schemes work in the MI field as well, where there is no dependency respect to the MCS. On the contrary, the HARQ model of EESM works in the effective SINR field, which is MCS dependent, and does not allow the combination of HARQ blocks using different MCSs [wimaxEmd].

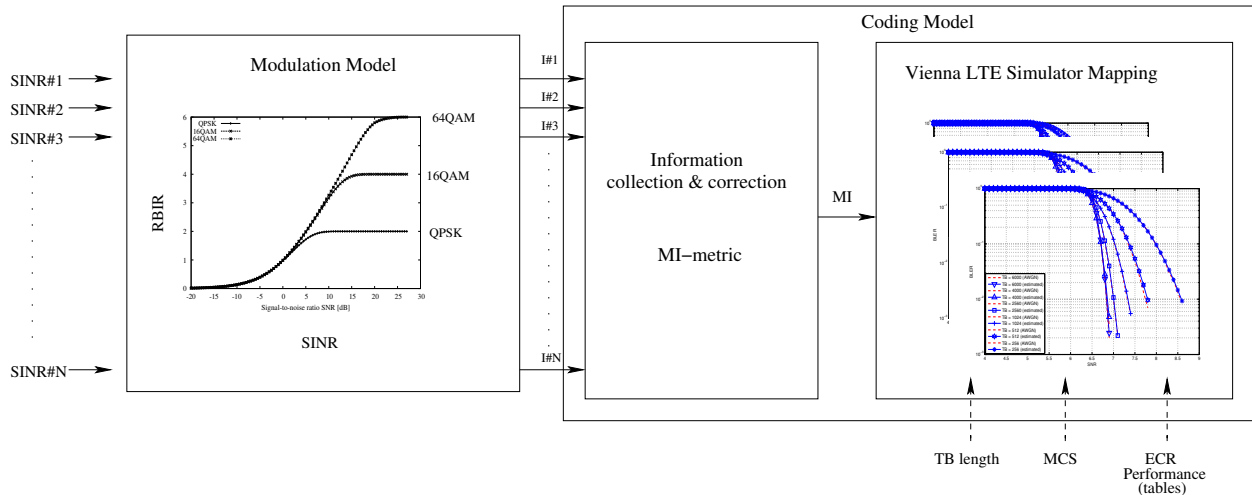

Figure 16.14: MIESM computational procedure diagram

The mutual information (MI) is dependent on the constellation mapping and can be calculated per transport block (TB) basis, by evaluating the MI over the symbols and the subcarrier. However, this would be too complex for a network simulator. Hence, in our implementation a flat channel response within the RB has been considered; therefore the overall MI of a TB is calculated averaging the MI evaluated per each RB used in the TB. In detail, the implemented scheme is depicted in Figure *MIESM computational procedure diagram*, where we see that the model starts by evaluating the MI value for each RB, represented in the figure by the SINR samples. Then the equivalent MI is evaluated per TB basis by averaging the MI values. Finally, a further step has to be done since the link level simulator returns the performance of the link in terms of block error rate (BLER) in a additive white gaussian noise (AWGN) channel, where the blocks are the code blocks (CBs) independently encoded/decoded by the turbo encoder. On this matter the standard 3GPP segmentation scheme has been used for estimating the actual CB size (described in section 5.1.2 of [TS36212]). This scheme divides the the TB in  $N_{K-}$  blocks of size  $K_-$  and  $N_{K+}$  blocks of size  $K_+$ . Therefore the overall TB BLER (TBLER) can be expressed as

$$TBLER = 1 - \prod_{i=1}^C (1 - CBLER_i)$$

where the  $CBLE R_i$  is the BLER of the CB  $i$  obtained according to the link level simulator CB BLER curves. For estimating the  $CBLE R_i$ , the MI evaluation has been implemented according to its numerical approximation defined in [wimaxEmd]. Moreover, for reducing the complexity of the computation, the approximation has been converted into lookup tables. In detail, Gaussian cumulative model has been used for approximating the AWGN BLER curves with three parameters which provides a close fit to the standard AWGN performances, in formula:

$$CBLE R_i = \frac{1}{2} \left[ 1 - \operatorname{erf} \left( \frac{x - b_{ECR}}{\sqrt{2}c_{ECR}} \right) \right]$$

where  $x$  is the MI of the TB,  $b_{ECR}$  represents the “transition center” and  $c_{ECR}$  is related to the “transition width” of the Gaussian cumulative distribution for each Effective Code Rate (ECR) which is the actual transmission rate according to the channel coding and MCS. For limiting the computational complexity of the model we considered only a subset of the possible ECRs in fact we would have potentially 5076 possible ECRs (i.e., 27 MCSs and 188 CB sizes). On this respect, we will limit the CB sizes to some representative values (i.e., 40, 140, 160, 256, 512, 1024, 2048, 4032, 6144), while for the others the worst one approximating the real one will be used (i.e., the smaller CB size value available respect to the real one). This choice is aligned to the typical performance of turbo codes, where the CB size is not strongly impacting on the BLER. However, it is to be notes that for CB sizes lower than 1000 bits the effect might be relevant (i.e., till 2 dB); therefore, we adopt this unbalanced sampling interval for having more precision where it is necessary. This behaviour is confirmed by the figures presented in the Annes Section.

**BLER Curves** On this respect, we reused part of the curves obtained within [PaduaPEM]. In detail, we introduced the CB size dependency to the CB BLER curves with the support of the developers of [PaduaPEM] and of the LTE Vienna Simulator. In fact, the module released provides the link layer performance only for what concerns the MCSs (i.e, with a given fixed ECR). In detail the new error rate curves for each has been evaluated with a simulation campaign with the link layer simulator for a single link with AWGN noise and for CB size of 104, 140, 256, 512, 1024, 2048, 4032 and 6144. These curves has been mapped with the Gaussian cumulative model formula presented above for obtaining the correspondents  $b_{ECR}$  and  $c_{ECR}$  parameters.

The BLER performance of all MCS obtained with the link level simulator are plotted in the following figures (blue lines) together with their correspondent mapping to the Gaussian cumulative distribution (red dashed lines).

**Integration of the BLER curves in the ns-3 LTE module** The model implemented uses the curves for the LSM of the recently LTE PHY Error Model released in the ns3 community by the Signet Group [PaduaPEM] and the new ones generated for different CB sizes. The `LteSpectrumPhy` class is in charge of evaluating the TB BLER thanks to the methods provided by the `LteMiErrorModel` class, which is in charge of evaluating the TB BLER according to the vector of the perceived SINR per RB, the MCS and the size in order to proper model the segmentation of the TB in CBs. In order to obtain the vector of the perceived SINR two instances of `LtePemSnrChunkProcessor` (child of `LteSnrChunkProcessor` dedicated to evaluate the SINR for obtaining physical error performance) have been attached to UE downlink and eNB uplink `LteSpectrumPhy` modules for evaluating the error model distribution respectively of PDSCH (UE side) and ULSCH (eNB side).

The model can be disabled for working with a zero-losses channel by setting the `PemEnabled` attribute of the `LteSpectrumPhy` class (by default is active). This can be done according to the standard ns3 attribute system procedure, that is:

```
Config::SetDefault ("ns3::LteSpectrumPhy::PemEnabled", BooleanValue (false));
```

## MIMO Model

The use of multiple antennas both at transmitter and receiver side, known as multiple-input and multiple-output (MIMO), is a problem well studied in literature during the past years. Most of the work concentrate on evaluating analytically the gain that the different MIMO schemes might have in term of capacity; however someones provide also information of the gain in terms of received power `_[CatreuxMIMO]`.

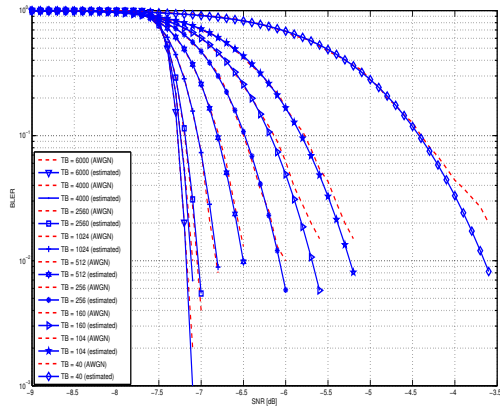

a) MCS 1

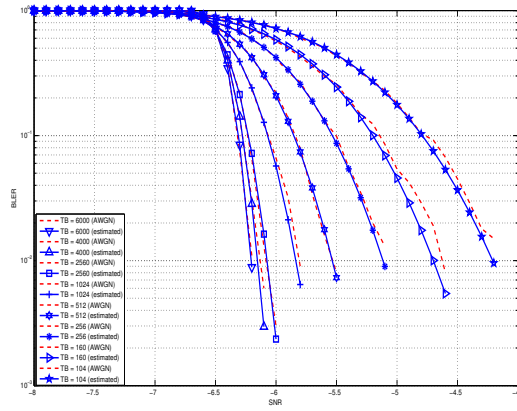

b) MCS 2

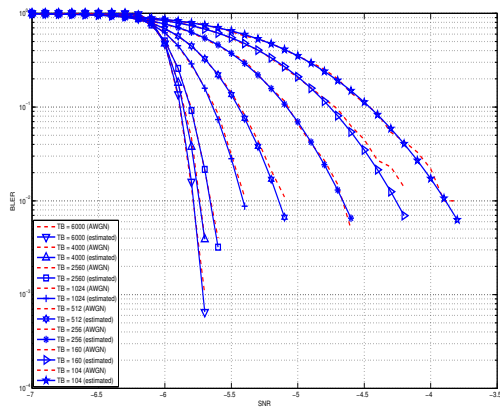

c) MCS 3

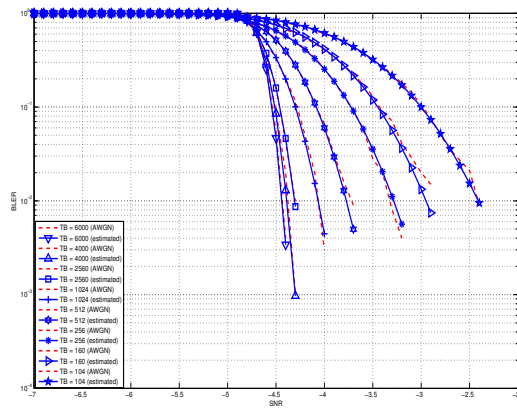

d) MCS 4

Figure 16.15: BLER for MCS 1, 2, 3 and 4.

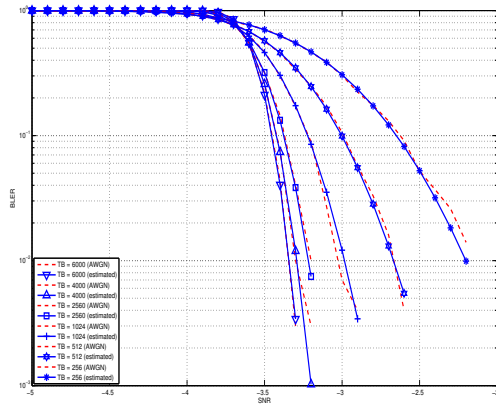

a) MCS 5

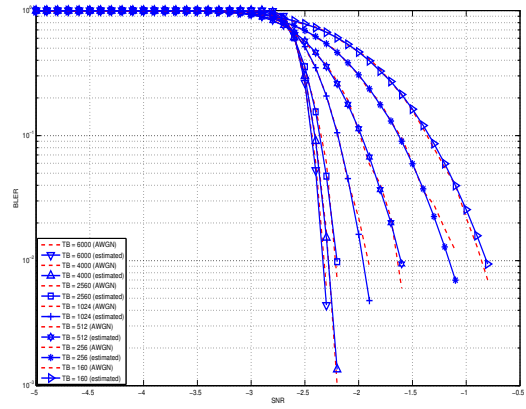

b) MCS 6

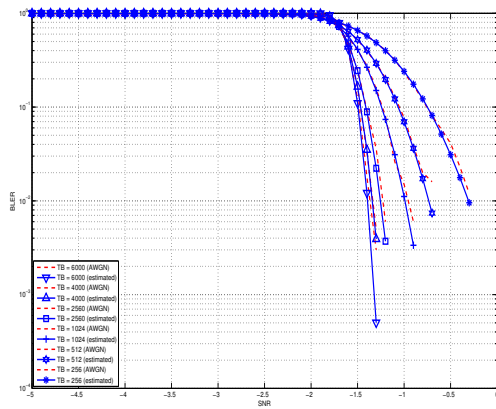

c) MCS 7

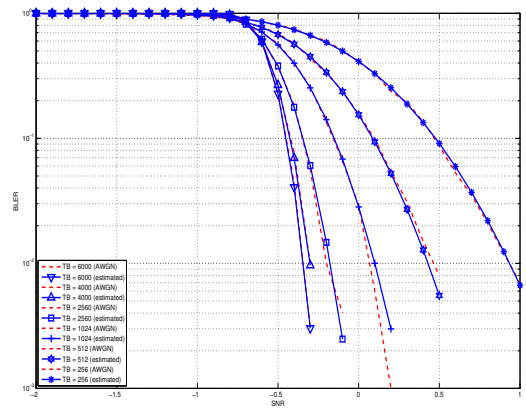

d) MCS 8

Figure 16.16: BLER for MCS 5, 6, 7 and 8.



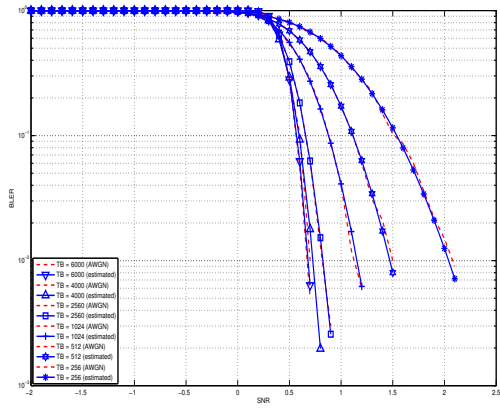

a) MCS 9

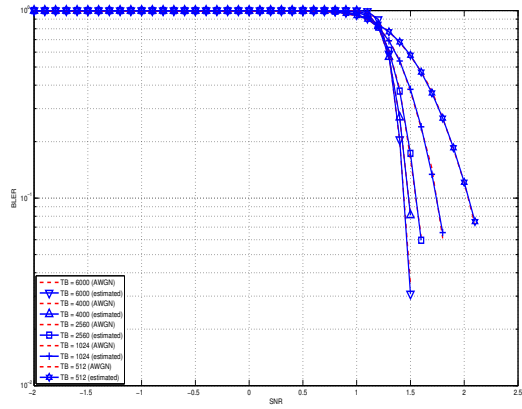

b) MCS 10

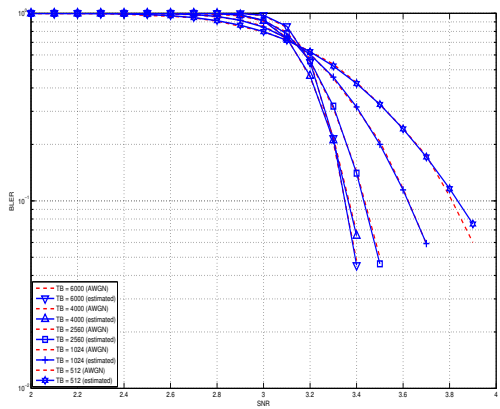

c) MCS 11

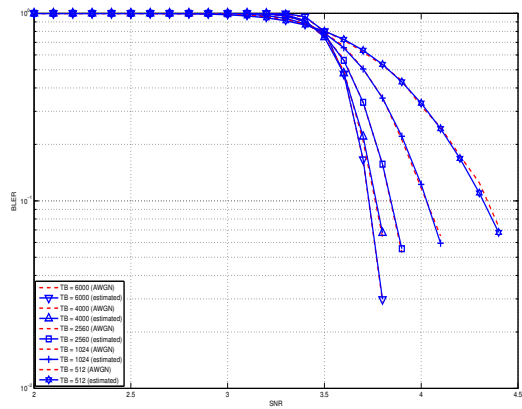

d) MCS 12

Figure 16.17: BLER for MCS 9, 10, 11 and 12.

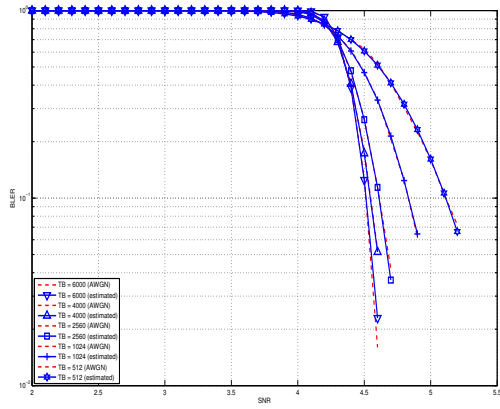

a) MCS 13

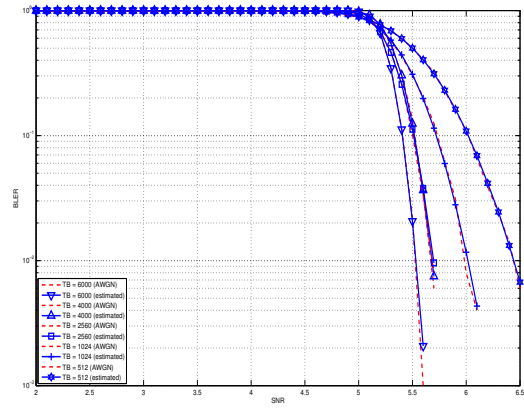

b) MCS 14

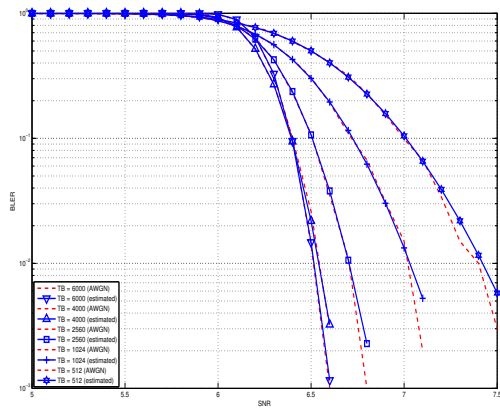

c) MCS 15

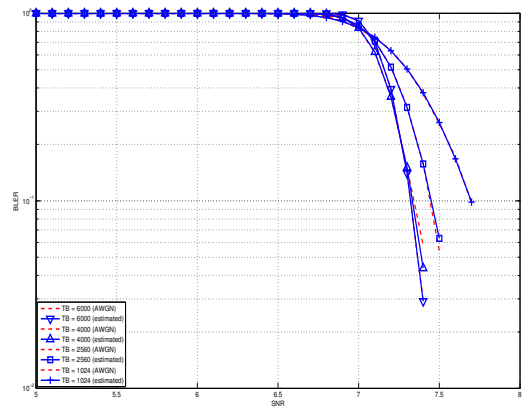

d) MCS 16

Figure 16.18: BLER for MCS 13, 14, 15 and 16.

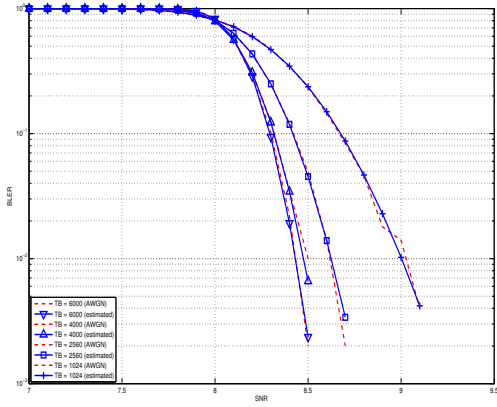

a) MCS 17

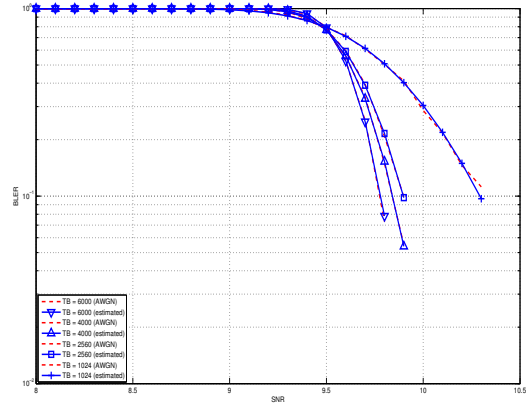

b) MCS 18

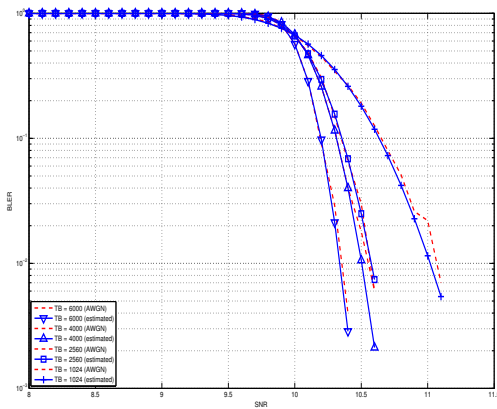

c) MCS 19

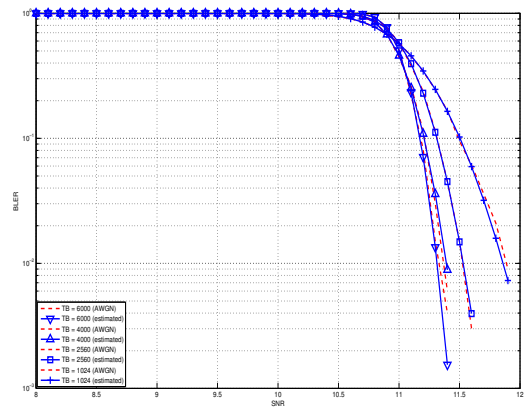

d) MCS 20

Figure 16.19: BLER for MCS 17, 17, 19 and 20.

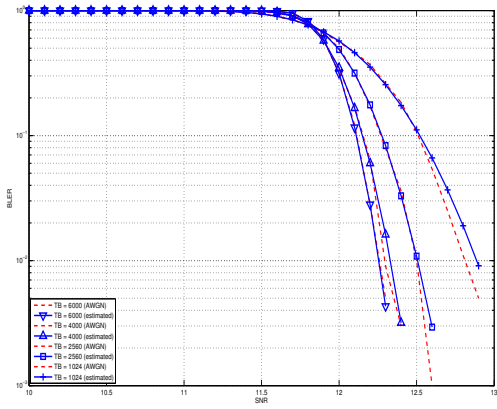

a) MCS 21

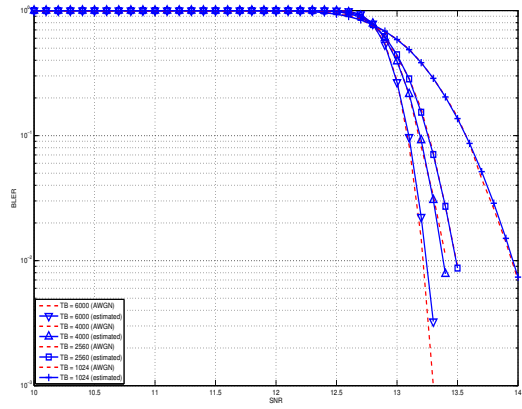

b) MCS 22

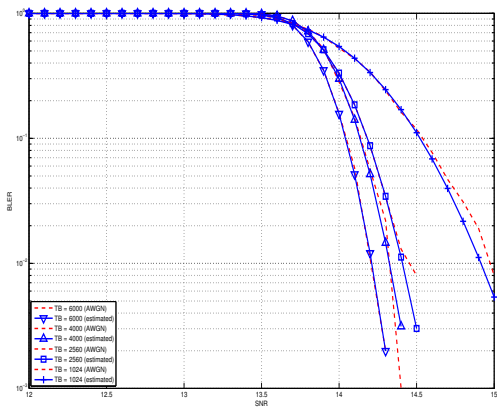

c) MCS 23

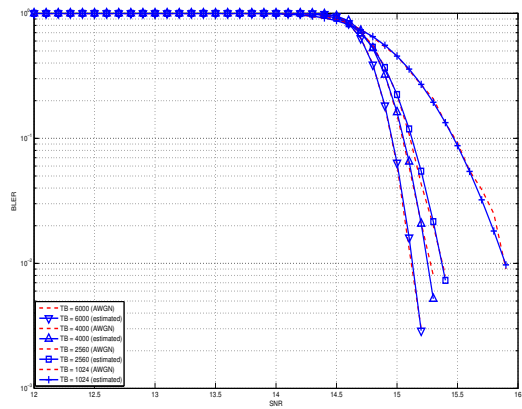

d) MCS 24

Figure 16.20: BLER for MCS 21, 22, 23 and 24.

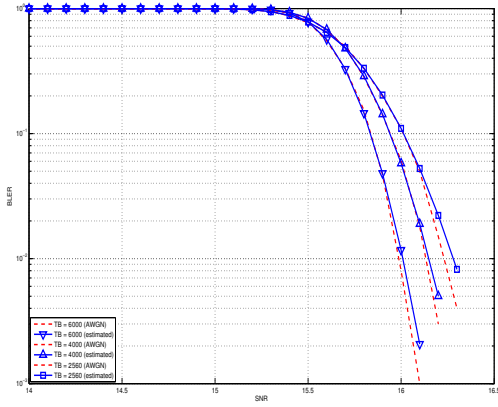

a) MCS 25

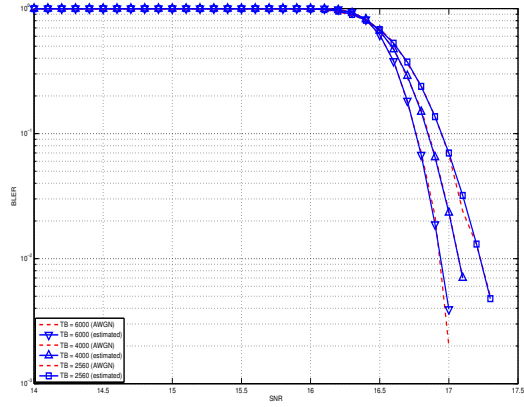

b) MCS 26

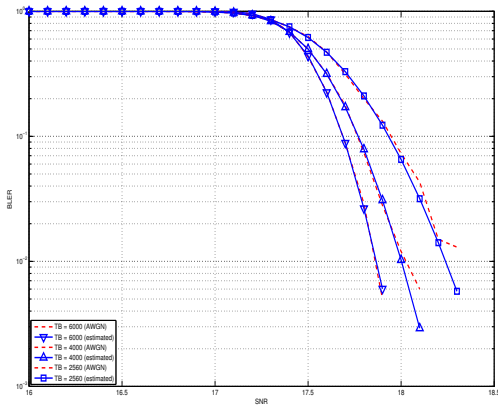

c) MCS 27

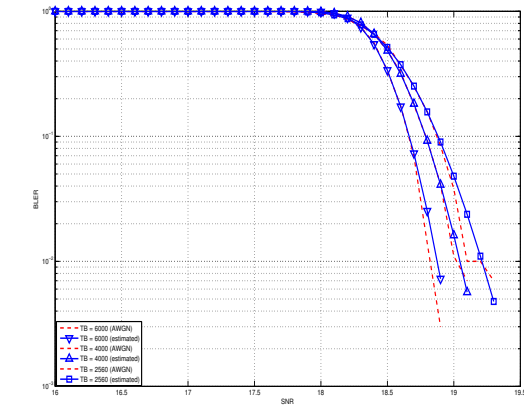

c) MCS 28

Figure 16.21: BLER for MCS 25, 26, 27 and 28.

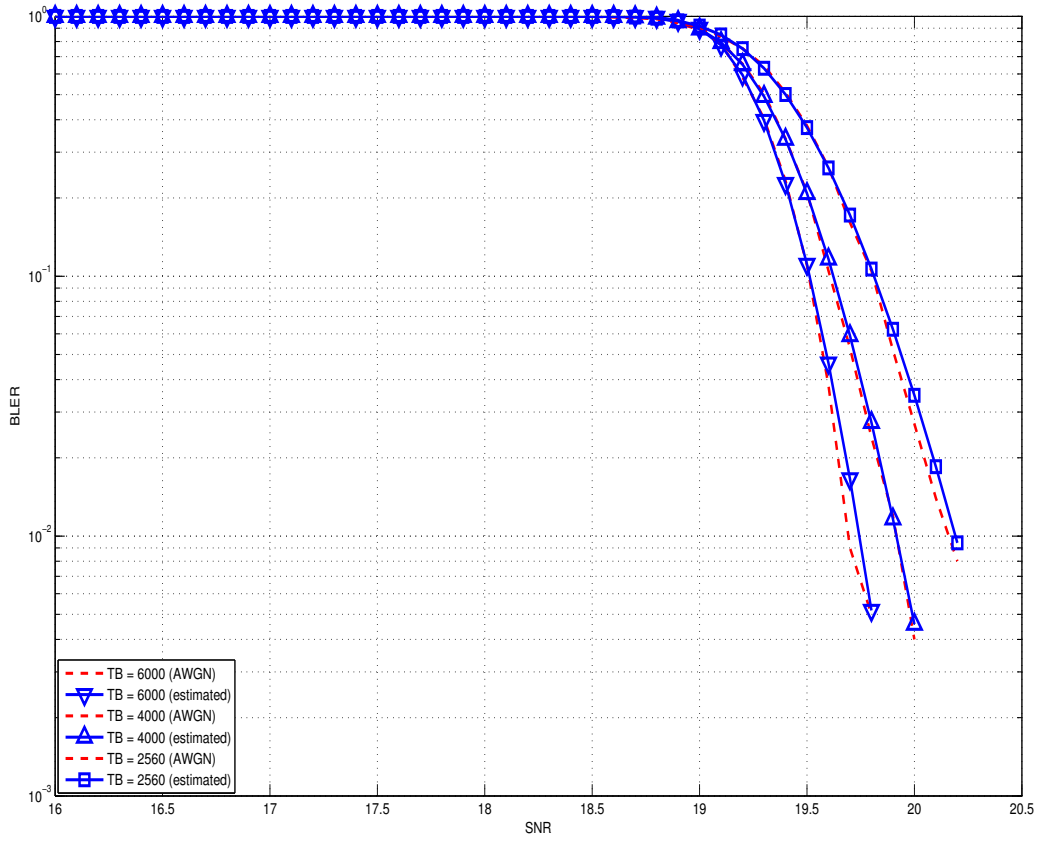

Figure 16.22: BLER for MCS 29.

According to the considerations above, a model more flexible can be obtained considering the gain that MIMO schemes bring in the system from a statistical point of view. As highlighted before, `_[CatreuxMIMO]` presents the statistical gain of several MIMO solutions respect to the SISO one in case of no correlation between the antennas. In the work the gain is presented as the cumulative distribution function (CDF) of the output SINR for what concern SISO, MIMO-Alamouti, MIMO-MMSE, MIMO-OSIC-MMSE and MIMO-ZF schemes. Elaborating the results, the output SINR distribution can be approximated with a log-normal one with different mean and variance as function of the scheme considered. However, the variances are not so different and they are approximatively equal to the one of the SISO mode already included in the shadowing component of the `BuildingsPropagationLossModel`, in detail:

- SISO:  $\mu = 13.5$  and  $\sigma = 20$  [dB].
- MIMO-Alamouti:  $\mu = 17.7$  and  $\sigma = 11.1$  [dB].
- MIMO-MMSE:  $\mu = 10.7$  and  $\sigma = 16.6$  [dB].
- MIMO-OSIC-MMSE:  $\mu = 12.6$  and  $\sigma = 15.5$  [dB].
- MIMO-ZF:  $\mu = 10.3$  and  $\sigma = 12.6$  [dB].

Therefore the PHY layer implements the MIMO model as the gain perceived by the receiver when using a MIMO scheme respect to the one obtained using SISO one. We note that, these gains referred to a case where there is no correlation between the antennas in MIMO scheme; therefore do not model degradation due to paths correlation.

## 16.1.5 Channel and Propagation

The LTE module works with the channel objects provided by the Spectrum module, i.e., either `SingleModelSpectrumChannel` or `MultiModelSpectrumChannel`. Because of these, all the propagation models supported by these objects can be used within the LTE module.

### Use of the Buildings model with LTE

The recommended propagation model to be used with the LTE module is the one provided by the Buildings module, which was in fact designed specifically with LTE (though it can be used with other wireless technologies as well). Please refer to the documentation of the Buildings module for generic information on the propagation model it provides.

In this section we will highlight some considerations that specifically apply when the Buildings module is used together with the LTE module.

The naming convention used in the following will be:

- User equipment: UE
- Macro Base Station: MBS
- Small cell Base Station (e.g., pico/femtocell): SC

The LTE module considers FDD only, and implements downlink and uplink propagation separately. As a consequence, the following pathloss computations are performed

- MBS <-> UE (indoor and outdoor)
- SC (indoor and outdoor) <-> UE (indoor and outdoor)

The LTE model does not provide the following pathloss computations:

- UE <-> UE
- MBS <-> MBS
- MBS <-> SC

- SC <-> SC

The Buildings model does not know the actual type of the node; i.e., it is not aware of whether a transmitter node is a UE, a MBS, or a SC. Rather, the Buildings model only cares about the position of the node: whether it is indoor and outdoor, and what is its z-axis respect to the rooftop level. As a consequence, for an eNB node that is placed outdoor and at a z-coordinate above the rooftop level, the propagation models typical of MBS will be used by the Buildings module. Conversely, for an eNB that is placed outdoor but below the rooftop, or indoor, the propagation models typical of pico and femtocells will be used.

For communications involving at least one indoor node, the corresponding wall penetration losses will be calculated by the Buildings model. This covers the following use cases:

- MBS <-> indoor UE
- outdoor SC <-> indoor UE
- indoor SC <-> indoor UE
- indoor SC <-> outdoor UE

Please refer to the documentation of the Buildings module for details on the actual models used in each case.

## Fading Model

The LTE module includes a trace-based fading model derived from the one developed during the GSoC 2010 [Piro2011]. The main characteristic of this model is the fact that the fading evaluation during simulation run-time is based on pre-calculated traces. This is done to limit the computational complexity of the simulator. On the other hand, it needs huge structures for storing the traces; therefore, a trade-off between the number of possible parameters and the memory occupancy has to be found. The most important ones are:

- users' speed: relative speed between users (affects the Doppler frequency, which in turns affects the time-variance property of the fading)
- number of taps (and relative power): number of multiple paths considered, which affects the frequency property of the fading.
- time granularity of the trace: sampling time of the trace.
- frequency granularity of the trace: number of values in frequency to be evaluated.
- length of trace: ideally large as the simulation time, might be reduced by windowing mechanism.
- number of users: number of independent traces to be used (ideally one trace per user).

With respect to the mathematical channel propagation model, we suggest the one provided by the `rayleighchan` function of Matlab, since it provides a well accepted channel modelization both in time and frequency domain. For more information, the reader is referred to [mathworks].

The simulator provides a matlab script (`/lte/model/JakesTraces/fading-trace-generator.m`) for generating traces based on the format used by the simulator. In detail, the channel object created with the `rayleighchan` function is used for filtering a discrete-time impulse signal in order to obtain the channel impulse response. The filtering is repeated for different TTI, thus yielding subsequent time-correlated channel responses (one per TTI). The channel response is then processed with the `pwelch` function for obtaining its power spectral density values, which are then saved in a file with the proper format compatible with the simulator model.

Since the number of variable it is pretty high, generate traces considering all of them might produce a high number of traces of huge size. On this matter, we considered the following assumptions of the parameters based on the 3GPP fading propagation conditions (see Annex B.2 of [TS36104]):

- users' speed: typically only a few discrete values are considered, i.e.:
  - 0 and 3 kmph for pedestrian scenarios



- 30 and 60 kmph for vehicular scenarios
- 0, 3, 30 and 60 for urban scenarios
- channel taps: only a limited number of sets of channel taps are normally considered, for example three models are mentioned in Annex B.2 of [TS36104].
- time granularity: we need one fading value per TTI, i.e., every 1 ms (as this is the granularity in time of the ns-3 LTE PHY model).
- frequency granularity: we need one fading value per RB (which is the frequency granularity of the spectrum model used by the ns-3 LTE model).
- length of the trace: the simulator includes the windowing mechanism implemented during the GSoC 2011, which consists of picking up a window of the trace each window length in a random fashion.
- per-user fading process: users share the same fading trace, but for each user a different starting point in the trace is randomly picked up. This choice was made to avoid the need to provide one fading trace per user.

According to the parameters we considered, the following formula express in detail the total size  $S_{traces}$  of the fading traces:

$$S_{traces} = S_{sample} \times N_{RB} \times \frac{T_{trace}}{T_{sample}} \times N_{scenarios} \text{ [bytes]}$$

where  $S_{sample}$  is the size in bytes of the sample (e.g., 8 in case of double precision, 4 in case of float precision),  $N_{RB}$  is the number of RB or set of RBs to be considered,  $T_{trace}$  is the total length of the trace,  $T_{sample}$  is the time resolution of the trace (1 ms), and  $N_{scenarios}$  is the number of fading scenarios that are desired (i.e., combinations of different sets of channel taps and user speed values). We provide traces for 3 different scenarios one for each taps configuration defined in Annex B.2 of [TS36104]:

- Pedestrian: with nodes' speed of 3 kmph.
- Vehicular: with nodes' speed of 60 kmph.
- Urban: with nodes' speed of 3 kmph.

hence  $N_{scenarios} = 3$ . All traces have  $T_{trace} = 10$  s and  $RB_{NUM} = 100$ . This results in a total 24 MB bytes of traces.

## Antennas

Being based on the SpectrumPhy, the LTE PHY model supports antenna modeling via the ns-3 AntennaModel class. Hence, any model based on this class can be associated with any eNB or UE instance. For instance, the use of the CosineAntennaModel associated with an eNB device allows to model one sector of a macro base station. By default, the IsotropicAntennaModel is used for both eNBs and UEs.

### 16.1.6 Helpers

Two helper objects are use to setup simulations and configure the various components. These objects are:

- LteHelper, which takes care of the configuration of the LTE radio access network, as well as of coordinating the setup and release of EPS bearers
- EpcHelper, which takes care of the configuratio of the Evolved Packet Core

It is possible to create a simple LTE-only simulations by using LteHelper alone, or to create complete LTE-EPC simulations by using both LteHelper and EpcHelper. When both helpers are used, they interact in a master-slave fashion, with LteHelper being the Master that interacts directly with the user program, and EpcHelper working “under

the hood” to configure the EPC upon explicit methods called by `LteHelper`. The exact interactions are displayed in the Figure *Sequence diagram of the interaction between `LteHelper` and `EpcHelper`*.

A few notes on the above diagram:

- the role of the MME is taken by the `EpcHelper`, since we don’t have an MME at the moment (the current code supports data plane only);
- in a real LTE/EPC system, the setup of the `RadioBearer` comes after the setup of the S1 bearer, but here due to the use of `Helpers` instead of S1-AP messages we do it the other way around (`RadioBearers` first, then S1 bearer) because of easier implementation. This is fine to do since the current code focuses on control plane only.

## 16.2 User Documentation

### 16.2.1 Background

We assume the reader is already familiar with how to use the ns-3 simulator to run generic simulation programs. If this is not the case, we strongly recommend the reader to consult [\[ns3tutorial\]](#).

### 16.2.2 Usage Overview

The ns-3 LTE model is a software library that allows the simulation of LTE networks, optionally including the Evolved Packet Core (EPC). The process of performing such simulations typically involves the following steps:

1. *Define the scenario* to be simulated
2. *Write a simulation program* that recreates the desired scenario topology/architecture. This is done accessing the ns-3 LTE model library using the `ns3::LteHelper` API defined in `src/lte/helper/lte-helper.h`.
3. *Specify configuration parameters* of the objects that are being used for the simulation. This can be done using input files (via the `ns3::ConfigStore`) or directly within the simulation program.
4. *Configure the desired output* to be produced by the simulator
5. *Run* the simulation.

All these aspects will be explained in the following sections by means of practical examples.

### 16.2.3 Basic simulation program

Here is the minimal simulation program that is needed to do an LTE-only simulation (without EPC).

1. Initial boilerplate:

```
#include "ns3/core-module.h"
#include "ns3/network-module.h"
#include "ns3/mobility-module.h"
#include "ns3/lte-module.h"

using namespace ns3;

int main (int argc, char *argv[])
{
    // the rest of the simulation program follows
```

2. Create a `LteHelper` object:

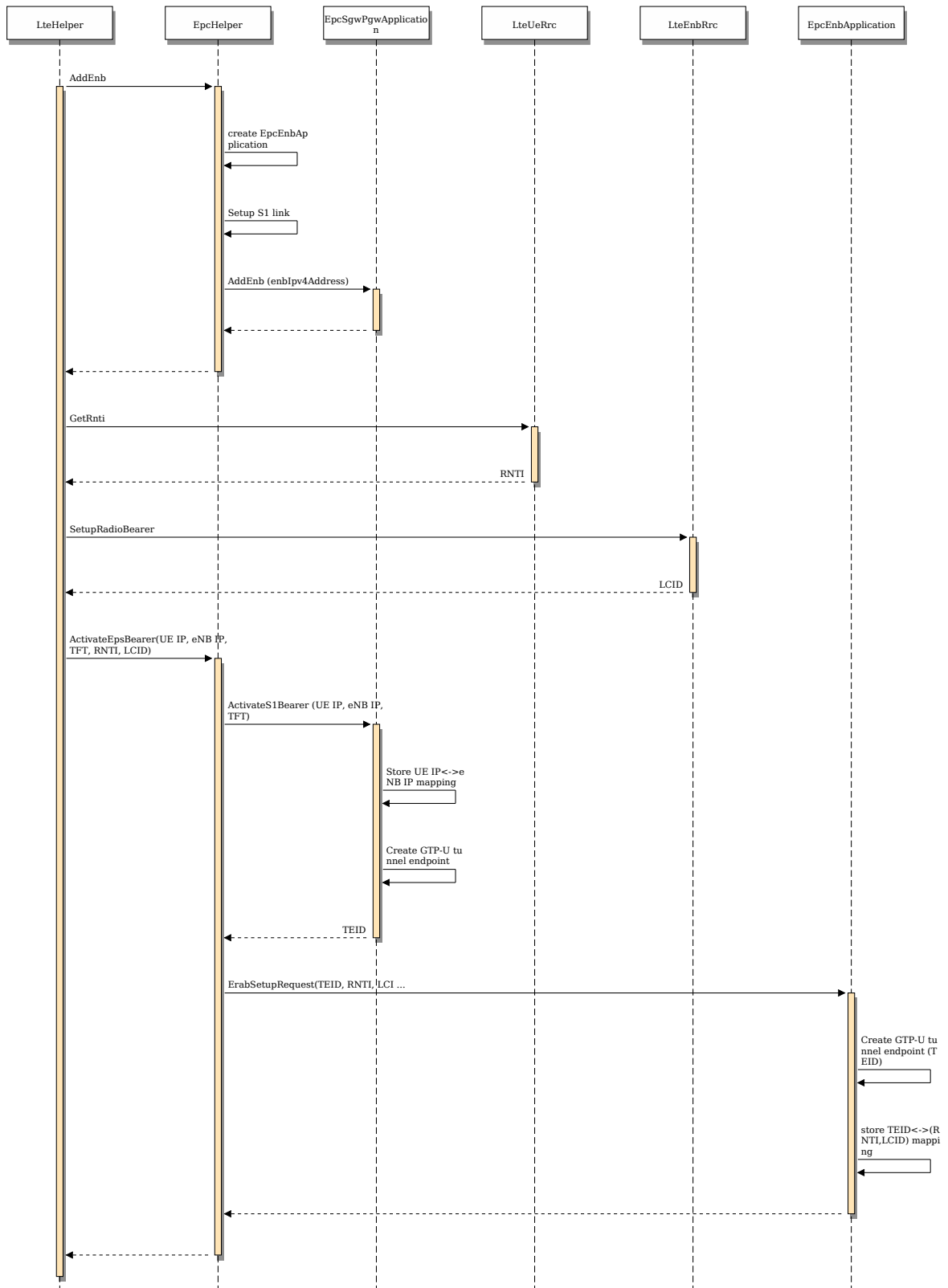

Figure 16.23: Sequence diagram of the interaction between LteHelper and EpcHelper

```
Ptr<LteHelper> lteHelper = CreateObject<LteHelper> ();
```

This will instantiate some common objects (e.g., the Channel object) and provide the methods to add eNBs and UEs and configure them.

3. Create Node objects for the eNB(s) and the UEs:

```
NodeContainer enbNodes;  
enbNodes.Create (1);  
NodeContainer ueNodes;  
ueNodes.Create (2);
```

Note that the above Node instances at this point still don't have an LTE protocol stack installed; they're just empty nodes.

4. Configure the Mobility model for all the nodes:

```
MobilityHelper mobility;  
mobility.SetMobilityModel ("ns3::ConstantPositionMobilityModel");  
mobility.Install (enbNodes);  
mobility.SetMobilityModel ("ns3::ConstantPositionMobilityModel");  
mobility.Install (ueNodes);
```

The above will place all nodes at the coordinates (0,0,0). Please refer to the documentation of the ns-3 mobility model for how to set your own position or configure node movement.

5. Install an LTE protocol stack on the eNB(s):

```
NetDeviceContainer enbDevs;  
enbDevs = lteHelper->InstallEnbDevice (enbNodes);
```

6. Install an LTE protocol stack on the UEs:

```
NetDeviceContainer ueDevs;  
ueDevs = lteHelper->InstallUeDevice (ueNodes);
```

7. Attach the UEs to an eNB. This will configure each UE according to the eNB configuration, and create an RRC connection between them:

```
lteHelper->Attach (ueDevs, enbDevs.Get (0));
```

8. Activate an EPS Bearer including the setup of the Radio Bearer between an eNB and its attached UE:

```
enum EpsBearer::Qci q = EpsBearer::GBR_CONV_VOICE;  
EpsBearer bearer (q);  
lteHelper->ActivateEpsBearer (ueDevs, bearer);
```

In the current version of the ns-3 LTE model, the activation of an EPS Bearer will also activate two saturation traffic generators for that bearer, one in uplink and one in downlink.

9. Set the stop time:

```
Simulator::Stop (Seconds (0.005));
```

This is needed otherwise the simulation will last forever, because (among others) the start-of-subframe event is scheduled repeatedly, and the ns-3 simulator scheduler will hence never run out of events.

10. Run the simulation:

```
Simulator::Run ();
```

11. Cleanup and exit:

```

    Simulator::Destroy ();
    return 0;
}

```

For how to compile and run simulation programs, please refer to [\[ns3tutorial\]](#).

## 16.2.4 Configuration of LTE model parameters

All the relevant LTE model parameters are managed through the ns-3 attribute system. Please refer to the [\[ns3tutorial\]](#) and [\[ns3manual\]](#) for detailed information on all the possible methods to do it (environmental variables, C++ API, GtkConfigStore...).

In the following, we just briefly summarize how to do it using input files together with the ns-3 ConfigStore. First of all, you need to put the following in your simulation program, right after `main ()` starts:

```

CommandLine cmd;
cmd.Parse (argc, argv);
ConfigStore inputConfig;
inputConfig.ConfigureDefaults ();
// parse again so you can override default values from the command line
cmd.Parse (argc, argv);

```

for the above to work, make sure you also `#include "ns3/config-store.h"`. Now create a text file named (for example) `input-defaults.txt` specifying the new default values that you want to use for some attributes:

```

default ns3::LteHelper::Scheduler "ns3::PffMacScheduler"
default ns3::LteHelper::PathlossModel "ns3::FriisSpectrumPropagationLossModel"
default ns3::LteEnbNetDevice::UlBandwidth "25"
default ns3::LteEnbNetDevice::DlBandwidth "25"
default ns3::LteEnbNetDevice::DlEarfcn "100"
default ns3::LteEnbNetDevice::UlEarfcn "18100"
default ns3::LteUePhy::TxPower "10"
default ns3::LteUePhy::NoiseFigure "9"
default ns3::LteEnbPhy::TxPower "30"
default ns3::LteEnbPhy::NoiseFigure "5"

```

Supposing your simulation program is called `src/lte/examples/lte-sim-with-input`, you can now pass these settings to the simulation program in the following way:

```
./waf --command-template="%s --ns3::ConfigStore::Filename=input-defaults.txt --ns3::ConfigStore::Mode
```

Furthermore, you can generate a template input file with the following command:

```
./waf --command-template="%s --ns3::ConfigStore::Filename=input-defaults.txt --ns3::ConfigStore::Mode
```

note that the above will put in the file `input-defaults.txt` *all* the default values that are registered in your particular build of the simulator, including lots of non-LTE attributes.

## 16.2.5 Simulation Output

The ns-3 LTE model currently supports the output to file of MAC, RLC and PDCP level Key Performance Indicators (KPIs). You can enable it in the following way:

```

Ptr<LteHelper> lteHelper = CreateObject<LteHelper> ();

// configure all the simulation scenario here...

```

```
lteHelper->EnableMacTraces ();  
lteHelper->EnableRlcTraces ();  
lteHelper->EnablePdcpcTraces ();  
  
Simulator::Run ();
```

RLC and PDCP KPIs are calculated over a time interval and stored on ASCII files, two for RLC KPIs and two for PDCP KPIs, in each case one for uplink and one for downlink. The time interval duration can be controlled using the attribute `ns3::RadioBearerStatsCalculator::EpochDuration`.

The columns of the RLC KPI files is the following (the same for uplink and downlink):

1. start time of measurement interval in seconds since the start of simulation
2. end time of measurement interval in seconds since the start of simulation
3. Cell ID
4. unique UE ID (IMSI)
5. cell-specific UE ID (RNTI)
6. Logical Channel ID
7. Number of transmitted RLC PDUs
8. Total bytes transmitted.
9. Number of received RLC PDUs
10. Total bytes received
11. Average RLC PDU delay in seconds
12. Standard deviation of the RLC PDU delay
13. Minimum value of the RLC PDU delay
14. Maximum value of the RLC PDU delay
15. Average RLC PDU size, in bytes
16. Standard deviation of the RLC PDU size
17. Minimum RLC PDU size
18. Maximum RLC PDU size

Similarly, the columns of the PDCP KPI files is the following (again, the same for uplink and downlink):

1. start time of measurement interval in seconds since the start of simulation
2. end time of measurement interval in seconds since the start of simulation
3. Cell ID
4. unique UE ID (IMSI)
5. cell-specific UE ID (RNTI)
6. Logical Channel ID
7. Number of transmitted PDCP PDUs
8. Total bytes transmitted.
9. Number of received PDCP PDUs
10. Total bytes received

11. Average PDCP PDU delay in seconds
12. Standard deviation of the PDCP PDU delay
13. Minimum value of the PDCP PDU delay
14. Maximum value of the PDCP PDU delay
15. Average PDCP PDU size, in bytes
16. Standard deviation of the PDCP PDU size
17. Minimum PDCP PDU size
18. Maximum PDCP PDU size

MAC KPIs are basically a trace of the resource allocation reported by the scheduler upon the start of every subframe. They are stored in ASCII files. For downlink MAC KPIs the format is the following:

1. Simulation time in seconds at which the allocation is indicated by the scheduler
2. Cell ID
3. unique UE ID (IMSI)
4. Frame number
5. Subframe number
6. cell-specific UE ID (RNTI)
7. MCS of TB 1
8. size of TB 1
9. MCS of TB 2 (0 if not present)
10. size of TB 2 (0 if not present)

while for uplink MAC KPIs the format is:

1. Simulation time in seconds at which the allocation is indicated by the scheduler
2. Cell ID
3. unique UE ID (IMSI)
4. Frame number
5. Subframe number
6. cell-specific UE ID (RNTI)
7. MCS of TB
8. size of TB

The names of the files used for MAC KPI output can be customized via the ns-3 attributes `ns3::MacStatsCalculator::DlOutputFilename` and `ns3::MacStatsCalculator::UlOutputFilename`.

## 16.2.6 Fading Trace Usage

In this section we will describe how to use fading traces within LTE simulations.

## Fading Traces Generation

It is possible to generate fading traces by using a dedicated matlab script provided with the code (`/lte/model/fading-traces/fading-trace-generator.m`). This script already includes the typical taps configurations for three 3GPP scenarios (i.e., pedestrian, vehicular and urban as defined in Annex B.2 of [TS36104]); however users can also introduce their specific configurations. The list of the configurable parameters is provided in the following:

- `fc` : the frequency in use (it affects the computation of the doppler speed).
- `v_km_h` : the speed of the users
- `traceDuration` : the duration in seconds of the total length of the trace.
- `numRBs` : the number of the resource block to be evaluated.
- `tag` : the tag to be applied to the file generated.

The file generated contains ASCII-formatted real values organized in a matrix fashion: every row corresponds to a different RB, and every column correspond to a different temporal fading trace sample.

It has to be noted that the ns-3 LTE module is able to work with any fading trace file that complies with the above described ASCII format. Hence, other external tools can be used to generate custom fading traces, such as for example other simulators or experimental devices.

## Fading Traces Usage

When using a fading trace, it is of paramount importance to specify correctly the trace parameters in the simulation, so that the fading model can load and use it correctly. The parameters to be configured are:

- `TraceFilename` : the name of the trace to be loaded (absolute path, or relative path w.r.t. the path from where the simulation program is executed);
- `TraceLength` : the trace duration in seconds;
- `SamplesNum` : the number of samples;
- `WindowSize` : the size of the fading sampling window in seconds;

It is important to highlight that the sampling interval of the fading trace has to be 1 ms or greater, and in the latter case it has to be an integer multiple of 1 ms in order to be correctly processed by the fading module.

The default configuration of the matlab script provides a trace 10 seconds long, made of 10,000 samples (i.e., 1 sample per TTI=1ms) and used with a windows size of 0.5 seconds amplitude. These are also the default values of the parameters above used in the simulator; therefore their settage can be avoided in case the fading trace respects them.

In order to activate the fading module (which is not active by default) the following code should be included in the simulation program:

```
Ptr<LteHelper> lteHelper = CreateObject<LteHelper> ();
lteHelper->SetFadingModel("ns3::TraceFadingLossModel");
```

And for setting the parameters:

```
lteHelper->SetFadingModelAttribute ("TraceFilename", StringValue ("src/lte/model/fading-traces/fading-trace-generator.m"));
lteHelper->SetFadingModelAttribute ("TraceLength", TimeValue (Seconds (10.0)));
lteHelper->SetFadingModelAttribute ("SamplesNum", UIntegerValue (10000));
lteHelper->SetFadingModelAttribute ("WindowSize", TimeValue (Seconds (0.5)));
lteHelper->SetFadingModelAttribute ("RbNum", UIntegerValue (100));
```



It has to be noted that, `TraceFilename` does not have a default value, therefore it has to be always set explicitly.

The simulator provides natively three fading traces generated according to the configurations defined in in Annex B.2 of [TS36104]. These traces are available in the folder `src/lte/model/fading-traces/`. An excerpt from these traces is represented in the following figures.

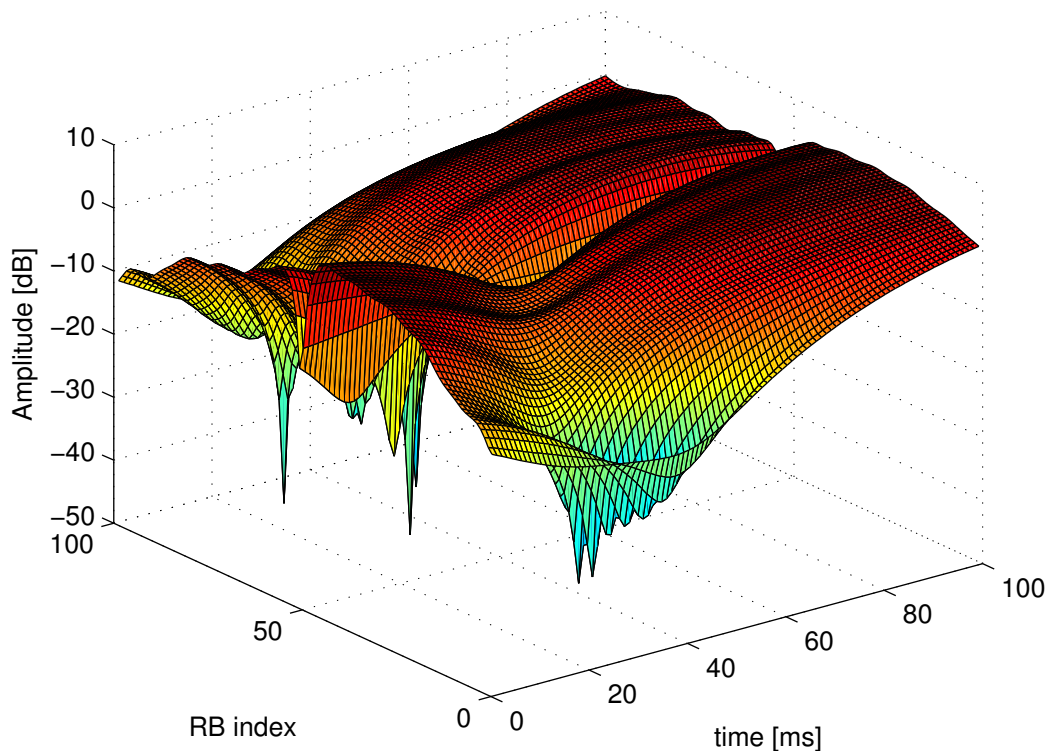

Figure 16.24: Excerpt of the fading trace included in the simulator for a pedestrian scenario (speed of 3 kmph).

## 16.2.7 Buildings Mobility Model

We now explain by examples how to use the buildings model (in particular, the `BuildingMobilityModel` and the `BuildingPropagationModel` classes) in an ns-3 simulation program to setup an LTE simulation scenario that includes buildings and indoor nodes.

1. Header files to be included:

```
#include <ns3/buildings-mobility-model.h>
#include <ns3/buildings-propagation-loss-model.h>
#include <ns3/building.h>
```

2. Pathloss model selection:

```
Ptr<LteHelper> lteHelper = CreateObject<LteHelper> ();

lteHelper->SetAttribute ("PathlossModel", StringValue ("ns3::BuildingsPropagationLossModel"));
```

3. EUTRA Band Selection

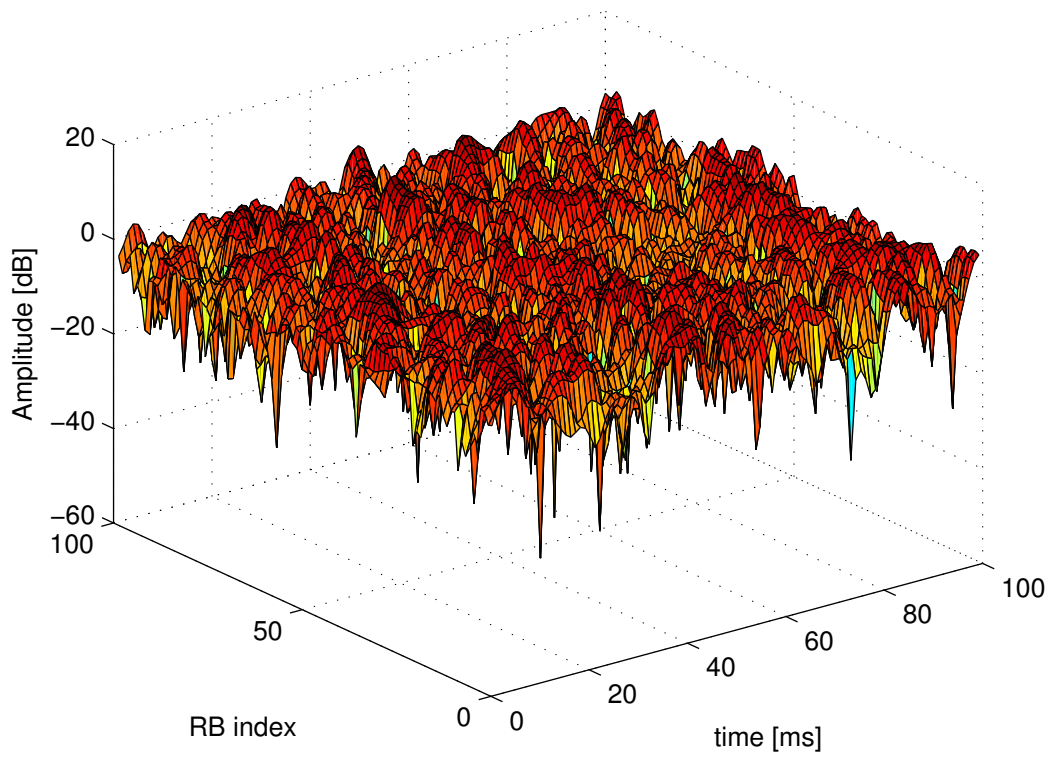

Figure 16.25: Excerpt of the fading trace included in the simulator for a vehicular scenario (speed of 60 kmph).

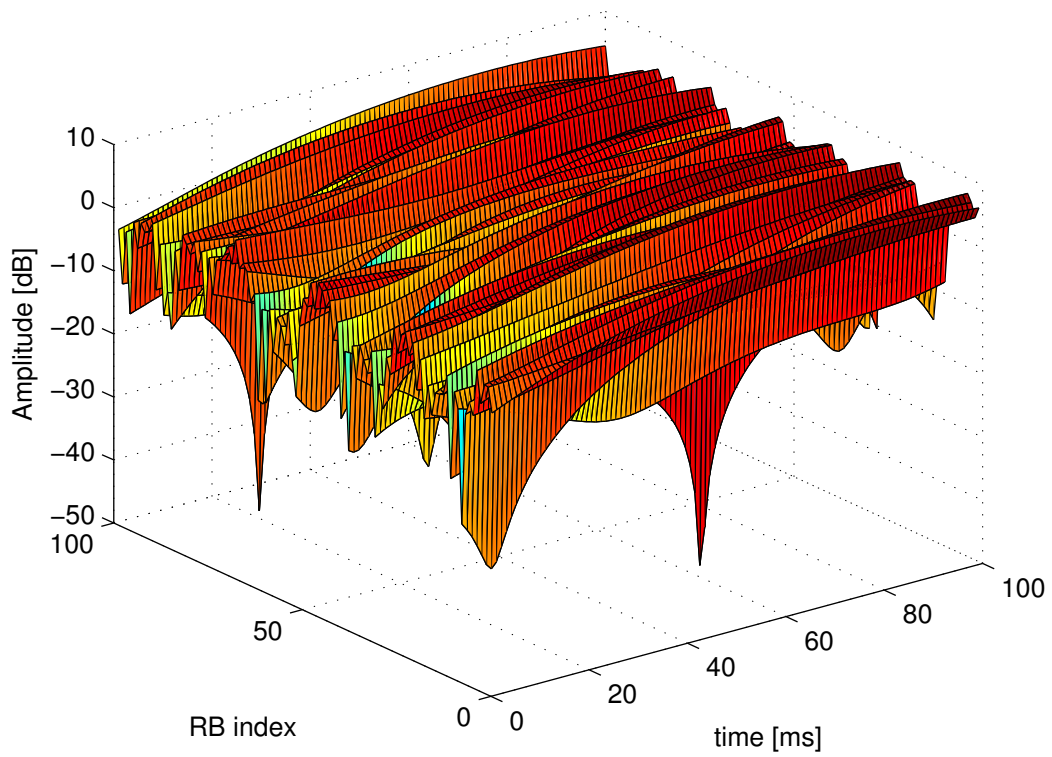

Figure 16.26: Excerpt of the fading trace included in the simulator for an urban scenario (speed of 3 kmph).

The selection of the working frequency of the propagation model has to be done with the standard ns-3 attribute system as described in the correspond section (“Configuration of LTE model parameters”) by means of the `DlEarfcn` and `UlEarfcn` parameters, for instance:

```
lteHelper->SetEnbDeviceAttribute ("DlEarfcn", UIntegerValue (100));
lteHelper->SetEnbDeviceAttribute ("UlEarfcn", UIntegerValue (18100));
```

It is to be noted that using other means to configure the frequency used by the propagation model (i.e., configuring the corresponding `BuildingsPropagationLossModel` attributes directly) might generates conflicts in the frequencies definition in the modules during the simulation, and is therefore not advised.

#### 1. Mobility model selection:

```
MobilityHelper mobility;
mobility.SetMobilityModel ("ns3::BuildingsMobilityModel");
```

#### 2. Building creation:

```
double x_min = 0.0;
double x_max = 10.0;
double y_min = 0.0;
double y_max = 20.0;
double z_min = 0.0;
double z_max = 10.0;
Ptr<Building> b = CreateObject <Building> ();
b->SetBoundaries (Box (x_min, x_max, y_min, y_max, z_min, z_max));
b->SetBuildingType (Building::Residential);
b->SetExtWallsType (Building::ConcreteWithWindows);
b->SetNFloors (3);
b->SetNRoomsX (3);
b->SetNRoomsY (2);
```

This will instantiate a residential building with base of 10 x 20 meters and height of 10 meters whose external walls are of concrete with windows; the building has three floors and has an internal 3 x 2 grid of rooms of equal size.

#### 3. Node creation and positioning:

```
ueNodes.Create (2);
mobility.Install (ueNodes);
NetDeviceContainer ueDevs;
ueDevs = lteHelper->InstallUeDevice (ueNodes);
Ptr<BuildingsMobilityModel> mm0 = enbNodes.Get (0)->GetObject<BuildingsMobilityModel> ();
Ptr<BuildingsMobilityModel> mm1 = enbNodes.Get (1)->GetObject<BuildingsMobilityModel> ();
mm0->SetPosition (Vector (5.0, 5.0, 1.5));
mm1->SetPosition (Vector (30.0, 40.0, 1.5));
```

This positions the node on the scenario. Note that, in this example, node 0 will be in the building, and node 1 will be out of the building. Note that this alone is not sufficient to setup the topology correctly. What is left to be done is to issue the following command after we have placed all nodes in the simulation:

```
BuildingsHelper::MakeMobilityModelConsistent ();
```

This command will go through the lists of all nodes and of all buildings, determine for each user if it is indoor or outdoor, and if indoor it will also determine the building in which the user is located and the corresponding floor and number inside the building.

## 16.2.8 MIMO Model

In this subsection we illustrate how to configure the MIMO parameters. LTE defines 7 types of transmission modes:

- Transmission Mode 1: SISO.
- Transmission Mode 2: MIMO Tx Diversity.
- Transmission Mode 3: MIMO Spatial Multiplexity Open Loop.
- Transmission Mode 4: MIMO Spatial Multiplexity Closed Loop.
- Transmission Mode 5: MIMO Multi-User.
- Transmission Mode 6: Closer loop single layer precoding.
- Transmission Mode 7: Single antenna port 5.

According to model implemented, the simulator includes the first three transmission modes types. The default one is the Transmission Mode 1 (SISO). In order to change the default Transmission Mode to be used, the attribute `DefaultTransmissionMode` of the `LteEnbRrc` can be used, as shown in the following:

```
Config::SetDefault ("ns3::LteEnbRrc::DefaultTransmissionMode", UintegerValue (0)); // SISO
Config::SetDefault ("ns3::LteEnbRrc::DefaultTransmissionMode", UintegerValue (1)); // MIMO Tx divers
Config::SetDefault ("ns3::LteEnbRrc::DefaultTransmissionMode", UintegerValue (2)); // MIMO Spatial M
```

For changing the transmission mode of a certain user during the simulation a specific interface has been implemented in both standard schedulers:

```
void TransmissionModeConfigurationUpdate (uint16_t rnti, uint8_t txMode);
```

This method can be used both for developing transmission mode decision engine (i.e., for optimizing the transmission mode according to channel condition and/or user's requirements) and for manual switching from simulation script. In the latter case, the switching can be done as shown in the following:

```
Ptr<LteEnbNetDevice> lteEnbDev = enbDevs.Get (0)->GetObject<LteEnbNetDevice> ();
PointerValue ptrval;
enbNetDev->GetAttribute ("FfMacScheduler", ptrval);
Ptr<RrFfMacScheduler> rrsched = ptrval.Get<RrFfMacScheduler> ();
Simulator::Schedule (Seconds (0.2), &RrFfMacScheduler::TransmissionModeConfigurationUpdate, rrsched,
```

Finally, the model implemented can be reconfigured according to different MIMO models by updating the gain values (the only constraints is that the gain has to be constant during simulation run-time and common for the layers). The gain of each Transmission Mode can be changed according to the standard ns3 attribute system, where the attributes are: `TxMode1Gain`, `TxMode2Gain`, `TxMode3Gain`, `TxMode4Gain`, `TxMode5Gain`, `TxMode6Gain` and `TxMode7Gain`. By default only `TxMode1Gain`, `TxMode2Gain` and `TxMode3Gain` have a meaningful value, that are the ones derived by `_[CatreuxMIMO]` (i.e., respectively 0.0, 4.2 and -2.8 dB).

## 16.2.9 Use of AntennaModel

We now show how associate a particular `AntennaModel` with an eNB device in order to model a sector of a macro eNB. For this purpose, it is convenient to use the `CosineAntennaModel` provided by the ns-3 antenna module. The configuration of the eNB is to be done via the `LteHelper` instance right before the creation of the `EnbNetDevice`, as shown in the following:

```
lteHelper->SetEnbAntennaModelType ("ns3::CosineAntennaModel");
lteHelper->SetEnbAntennaModelAttribute ("Orientation", DoubleValue (0));
lteHelper->SetEnbAntennaModelAttribute ("Beamwidth", DoubleValue (60));
lteHelper->SetEnbAntennaModelAttribute ("MaxGain", DoubleValue (0.0));
```

the above code will generate an antenna model with a 60 degrees beamwidth pointing along the X axis. The orientation is measured in degrees from the X axis, e.g., an orientation of 90 would point along the Y axis, and an orientation of -90 would point in the negative direction along the Y axis. The beamwidth is the -3 dB beamwidth, e.g, for a 60 degree beamwidth the antenna gain at an angle of  $\pm 30$  degrees from the direction of orientation is -3 dB.

To create a multi-sector site, you need to create different ns-3 nodes placed at the same position, and to configure separate `EnbNetDevice` with different antenna orientations to be installed on each node.

### 16.2.10 Radio Environment Maps

By using the class `RadioEnvironmentMapHelper` it is possible to output to a file a Radio Environment Map (REM), i.e., a uniform 2D grid of values that represent the Signal-to-noise ratio in the downlink with respect to the eNB that has the strongest signal at each point.

To do this, you just need to add the following code to your simulation program towards the end, right before the call to `Simulator::Run ()`:

```
Ptr<RadioEnvironmentMapHelper> remHelper = CreateObject<RadioEnvironmentMapHelper> ();
remHelper->SetAttribute ("ChannelPath", StringValue ("/ChannelList/0"));
remHelper->SetAttribute ("OutputFile", StringValue ("rem.out"));
remHelper->SetAttribute ("XMin", DoubleValue (-400.0));
remHelper->SetAttribute ("XMax", DoubleValue (400.0));
remHelper->SetAttribute ("XRes", UIntegerValue (100));
remHelper->SetAttribute ("YMin", DoubleValue (-300.0));
remHelper->SetAttribute ("YMax", DoubleValue (300.0));
remHelper->SetAttribute ("YRes", UIntegerValue (75));
remHelper->SetAttribute ("Z", DoubleValue (0.0));
remHelper->Install ();
```

By configuring the attributes of the `RadioEnvironmentMapHelper` object as shown above, you can tune the parameters of the REM to be generated. Note that each `RadioEnvironmentMapHelper` instance can generate only one REM; if you want to generate more REMs, you need to create one separate instance for each REM.

Note that the REM generation is very demanding, in particular:

- the run-time memory consumption is approximately 5KB per pixel. For example, a REM with a resolution of 500x500 needs about 1.25 GB of memory, and a resolution of 1000x1000 needs about 5 GB (too much for a regular PC at the time of this writing).
- if you generate a REM at the beginning of a simulation, it will slow down the execution of the rest of the simulation. If you want to generate a REM for a program and also use the same program to get simulation result, it is recommended to add a command-line switch that allows to either generate the REM or run the complete simulation. For this purpose, note that there is an attribute `RadioEnvironmentMapHelper::StopWhenDone` (default: true) that will force the simulation to stop right after the REM has been generated.

The REM is stored in an ASCII file in the following format:

- column 1 is the x coordinate
- column 2 is the y coordinate
- column 3 is the z coordinate
- column 4 is the SINR in linear units

A minimal gnuplot script that allows you to plot the REM is given below:

```
set view map;
set xlabel "X"
set ylabel "Y"
```

```

set clabel "SINR (dB)"
unset key
plot "rem.out" using ($1):($2):(10*log10($4)) with image

```

As an example, here is the REM that can be obtained with the example program `lena-dual-stripe`, which shows a three-sector LTE macrocell in a co-channel deployment with some residential femtocells randomly deployed in two blocks of apartments.

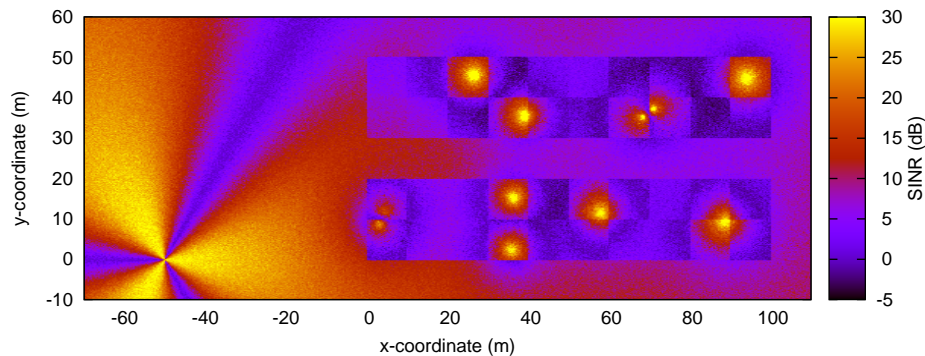

Figure 16.27: REM obtained from the lena-dual-stripe example

### 16.2.11 AMC Model and CQI Calculation

The simulator provides two possible schemes for what concerns the selection of the MCSs and correspondingly the generation of the CQIs. The first one is based on the GSoc module [Piro2011] and works per RB basis. This model can be activated with the ns3 attribute system, as presented in the following:

```
Config::SetDefault ("ns3::LteAmc::AmcModel", EnumValue (LteAmc::PiroEW2010));
```

While, the solution based on the physical error model can be controlled with:

```
Config::SetDefault ("ns3::LteAmc::AmcModel", EnumValue (LteAmc::MiErrorModel));
```

Finally, the required efficiency of the PiroEW2010 AMC module can be tuned thanks to the `Ber` attribute (), for instance:

```
Config::SetDefault ("ns3::LteAmc::Ber", DoubleValue (0.00005));
```

### 16.2.12 Evolved Packet Core (EPC)

We now explain how to write a simulation program that allows to simulate the EPC in addition to the LTE radio access network. The use of EPC allows to use IPv4 networking with LTE devices. In other words, you will be able to use

the regular ns-3 applications and sockets over IPv4 over LTE, and also to connect an LTE network to any other IPv4 network you might have in your simulation.

First of all, in your simulation program you need to create two helpers:

```
Ptr<LteHelper> lteHelper = CreateObject<LteHelper> ();
Ptr<EpcHelper> epcHelper = CreateObject<EpcHelper> ();
```

Then, you need to tell the LTE helper that the EPC will be used:

```
lteHelper->SetEpcHelper (epcHelper);
```

the above step is necessary so that the LTE helper will trigger the appropriate EPC configuration in correspondance with some important configuration, such as when a new eNB or UE is added to the simulation, or an EPS bearer is created. The EPC helper will automatically take care of the necessary setup, such as S1 link creation and S1 bearer setup. All this will be done without the intervention of the user.

It is to be noted that, upon construction, the EpcHelper will also create and configure the PGW node. Its configuration in particular is very complex, and hence is done automatically by the Helper. Still, it is allowed to access the PGW node in order to connect it to other IPv4 network (e.g., the internet). Here is a very simple example about how to connect a single remote host to the PGW via a point-to-point link:

```
Ptr<Node> pgw = epcHelper->GetPgwNode ();

// Create a single RemoteHost
NodeContainer remoteHostContainer;
remoteHostContainer.Create (1);
Ptr<Node> remoteHost = remoteHostContainer.Get (0);
InternetStackHelper internet;
internet.Install (remoteHostContainer);

// Create the internet
PointToPointHelper p2ph;
p2ph.SetDeviceAttribute ("DataRate", DataRateValue (DataRate ("100Gb/s")));
p2ph.SetDeviceAttribute ("Mtu", UintegerValue (1500));
p2ph.SetChannelAttribute ("Delay", TimeValue (Seconds (0.010)));
NetDeviceContainer internetDevices = p2ph.Install (pgw, remoteHost);
Ipv4AddressHelper ipv4h;
ipv4h.SetBase ("1.0.0.0", "255.0.0.0");
Ipv4InterfaceContainer internetIpIfaces = ipv4h.Assign (internetDevices);
// interface 0 is localhost, 1 is the p2p device
Ipv4Address remoteHostAddr = internetIpIfaces.GetAddress (1);
```

It's important to specify routes so that the remote host can reach LTE UEs. One way of doing this is by exploiting the fact that the EpcHelper will by default assign to LTE UEs an IP address in the 7.0.0.0 network. With this in mind, it suffices to do:

```
Ipv4StaticRoutingHelper ipv4RoutingHelper;
Ptr<Ipv4StaticRouting> remoteHostStaticRouting = ipv4RoutingHelper.GetStaticRouting (remoteHost->GetT
remoteHostStaticRouting->AddNetworkRouteTo (Ipv4Address ("7.0.0.0"), Ipv4Mask ("255.0.0.0"), 1);
```

Now, you should go on and create LTE eNBs and UEs as explained in the previous sections. You can of course configure other LTE aspects such as pathloss and fading models. Right after you created the UEs, you should also configure them for IP networking. This is done as follows. We assume you have a container for UE and eNodeB nodes like this:

```
NodeContainer ueNodes;
NodeContainer enbNodes;
```

to configure an LTE-only simulation, you would then normally do something like this:



```
NetDeviceContainer ueLteDevs = lteHelper->InstallUeDevice (ueNodes);
lteHelper->Attach (ueLteDevs, enbLteDevs.Get (0));
```

in order to configure the UEs for IP networking, you just need to additionally do like this:

```
// we install the IP stack on the UEs
InternetStackHelper internet;
internet.Install (ueNodes);

// assign IP address to UEs
for (uint32_t u = 0; u < ueNodes.GetN (); ++u)
{
    Ptr<Node> ue = ueNodes.Get (u);
    Ptr<NetDevice> ueLteDevice = ueLteDevs.Get (u);
    Ipv4InterfaceContainer ueIpIface = epcHelper->AssignUeIpv4Address (NetDeviceContainer (ueLteDevice));
    // set the default gateway for the UE
    Ptr<Ipv4StaticRouting> ueStaticRouting = ipv4RoutingHelper.GetStaticRouting (ue->GetObject<Ipv4StaticRouting> ());
    ueStaticRouting->SetDefaultRoute (epcHelper->GetUeDefaultGatewayAddress (), 1);
}
```

The activation of bearers is done exactly in the same way as for an LTE-only simulation. Here is how to activate a default bearer:

```
lteHelper->ActivateEpsBearer (ueLteDevs, EpsBearer (EpsBearer::NGBR_VIDEO_TCP_DEFAULT), EpcTft::Default);
```

you can of course use custom EpsBearer and EpcTft configurations, please refer to the doxygen documentation for how to do it.

Finally, you can install applications on the LTE UE nodes that communicate with remote applications over the internet. This is done following the usual ns-3 procedures. Following our simple example with a single remoteHost, here is how to setup downlink communication, with an UdpClient application on the remote host, and a PacketSink on the LTE UE (using the same variable names of the previous code snippets)

```
uint16_t dlPort = 1234;
PacketSinkHelper packetSinkHelper ("ns3::UdpSocketFactory", InetSocketAddress (Ipv4Address::GetAny (), dlPort));
ApplicationContainer serverApps = packetSinkHelper.Install (ue);
serverApps.Start (Seconds (0.01));
UdpClientHelper client (ueIpIface.GetAddress (0), dlPort);
ApplicationContainer clientApps = client.Install (remoteHost);
clientApps.Start (Seconds (0.01));
```

That's all! You can now start your simulation as usual:

```
Simulator::Stop (Seconds (10.0));
Simulator::Run ();
```

### 16.2.13 Examples Programs

The directory `src/lte/examples/` contains some example simulation programs that show how to simulate different LTE scenarios.

### 16.2.14 Reference scenarios

There is a vast amount of reference LTE simulation scenarios which can be found in the literature. Here we list some of them:

- The dual stripe model [R4-092042], which is partially implemented in the example program `src/lte/examples/lena-dual-stripe.cc`
- The system simulation scenarios mentioned in section A.2 of [TR36814]

## 16.3 Testing Documentation

### 16.3.1 Overview

To test and validate the ns-3 LTE module, several test suites are provided which are integrated with the ns-3 test framework. To run them, you need to have configured the build of the simulator in this way:

```
./waf configure --enable-tests --enable-modules=lte --enable-examples
./test.py
```

The above will run not only the test suites belonging to the LTE module, but also those belonging to all the other ns-3 modules on which the LTE module depends. See the ns-3 manual for generic information on the testing framework.

You can get a more detailed report in HTML format in this way:

```
./test.py -w results.html
```

After the above command has run, you can view the detailed result for each test by opening the file `results.html` with a web browser.

You can run each test suite separately using this command:

```
./test.py -s test-suite-name
```

For more details about `test.py` and the ns-3 testing framework, please refer to the ns-3 manual.

### 16.3.2 Description of the test suites

#### Unit Tests

##### SINR calculation in the Downlink

The test suite `lte-downlink-sinr` checks that the SINR calculation in downlink is performed correctly. The SINR in the downlink is calculated for each RB assigned to data transmissions by dividing the power of the intended signal from the considered eNB by the sum of the noise power plus all the transmissions on the same RB coming from other eNBs (the interference signals):

$$\gamma = \frac{P_{\text{signal}}}{P_{\text{noise}} + \sum P_{\text{interference}}}$$

In general, different signals can be active during different periods of time. We define a *chunk* as the time interval between any two events of type either start or end of a waveform. In other words, a chunk identifies a time interval during which the set of active waveforms does not change. Let  $i$  be the generic chunk,  $T_i$  its duration and  $\text{SINR}_i$  its SINR, calculated with the above equation. The calculation of the average SINR  $\bar{\gamma}$  to be used for CQI feedback reporting uses the following formula:

$$\bar{\gamma} = \frac{\sum_i \gamma_i T_i}{\sum_i T_i}$$

The test suite checks that the above calculation is performed correctly in the simulator. The test vectors are obtained offline by an Octave script that implements the above equation, and that recreates a number of random transmitted

signals and interference signals that mimic a scenario where an UE is trying to decode a signal from an eNB while facing interference from other eNBs. The test passes if the calculated values are equal to the test vector within a tolerance of  $10^{-7}$ . The tolerance is meant to account for the approximation errors typical of floating point arithmetic.

### SINR calculation in the Uplink

The test suite `lte-uplink-sinr` checks that the SINR calculation in uplink is performed correctly. This test suite is identical to `lte-downlink-sinr` described in the previous section, with the difference that both the signal and the interference now refer to transmissions by the UEs, and reception is performed by the eNB. This test suite recreates a number of random transmitted signals and interference signals to mimic a scenario where an eNB is trying to decode the signal from several UEs simultaneously (the ones in the cell of the eNB) while facing interference from other UEs (the ones belonging to other cells).

The test vectors are obtained by a dedicated Octave script. The test passes if the calculated values are equal to the test vector within a tolerance of  $10^{-7}$  which, as for the downlink SINR test, deals with floating point arithmetic approximation issues.

### E-UTRA Absolute Radio Frequency Channel Number (EARFCN)

The test suite `lte-earfcn` checks that the carrier frequency used by the `LteSpectrumValueHelper` class (which implements the LTE spectrum model) is done in compliance with [TS36101], where the E-UTRA Absolute Radio Frequency Channel Number (EARFCN) is defined. The test vector for this test suite comprises a set of EARFCN values and the corresponding carrier frequency calculated by hand following the specification of [TS36101]. The test passes if the carrier frequency returned by `LteSpectrumValueHelper` is the same as the known value for each element in the test vector.

## System Tests

### Adaptive Modulation and Coding Tests

The test suite `lte-link-adaptation` provides system tests recreating a scenario with a single eNB and a single UE. Different test cases are created corresponding to different SNR values perceived by the UE. The aim of the test is to check that in each test case the chosen MCS corresponds to some known reference values. These reference values are obtained by re-implementing in Octave (see `src/lte/test/reference/lte_amc.m`) the model described in Section *Adaptive Modulation and Coding* for the calculation of the spectral efficiency, and determining the corresponding MCS index by manually looking up the tables in [R1-081483]. The resulting test vector is represented in Figure *Test vector for Adaptive Modulation and Coding*.

The MCS which is used by the simulator is measured by obtaining the tracing output produced by the scheduler after 4ms (this is needed to account for the initial delay in CQI reporting). The SINR which is calculated by the simulator is also obtained using the `LteSinrChunkProcessor` interface. The test passes if both the following conditions are satisfied:

1. the SINR calculated by the simulator correspond to the SNR of the test vector within an absolute tolerance of  $10^{-7}$ ;
2. the MCS index used by the simulator exactly corresponds to the one in the test vector.

### Inter-cell Interference Tests

The test suite `lte-interference` provides system tests recreating an inter-cell interference scenario with two eNBs, each having a single UE attached to it and employing Adaptive Modulation and Coding both in the downlink and in

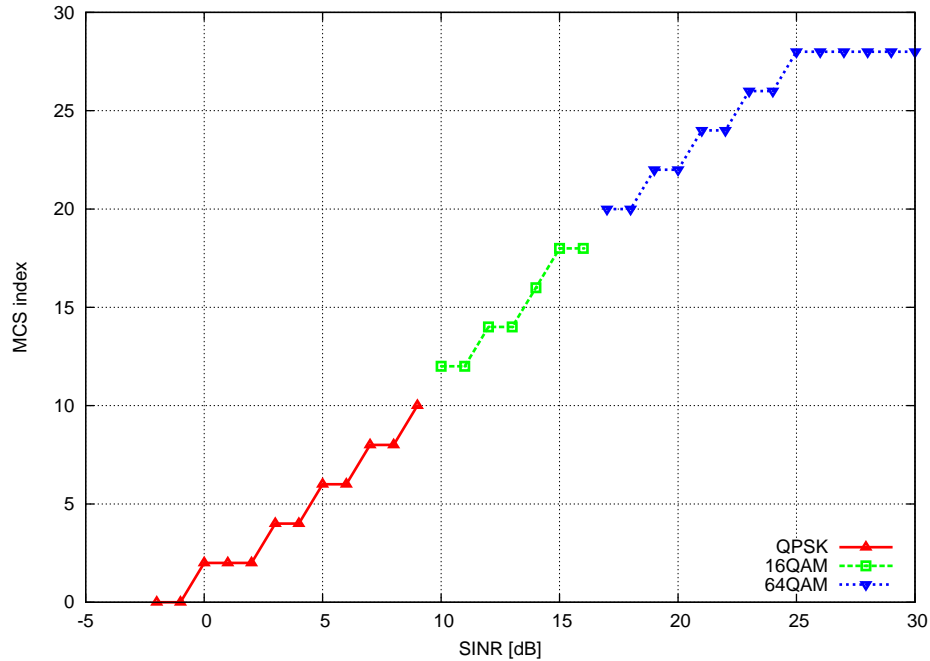

Figure 16.28: Test vector for Adaptive Modulation and Coding

the uplink. The topology of the scenario is depicted in Figure *Topology for the inter-cell interference test*. The  $d_1$  parameter represents the distance of each UE to the eNB it is attached to, whereas the  $d_2$  parameter represent the interferer distance. We note that the scenario topology is such that the interferer distance is the same for uplink and downlink; still, the actual interference power perceived will be different, because of the different propagation loss in the uplink and downlink bands. Different test cases are obtained by varying the  $d_1$  and  $d_2$  parameters.

The test vectors are obtained by use of a dedicated octave script (available in *src/lte/test/reference/lte\_link\_budget\_interference.m*), which does the link budget calculations (including interference) corresponding to the topology of each test case, and outputs the resulting SINR and spectral efficiency. The latter is then used to determine (using the same procedure adopted for *Adaptive Modulation and Coding Tests*). We note that the test vector contains separate values for uplink and downlink.

### Round Robin scheduler performance

The test suite `lte-rr-ff-mac-scheduler` creates different test cases with a single eNB and several UEs, all having the same Radio Bearer specification. In each test case, the UEs see the same SINR from the eNB; different test cases are implemented by using different distance among UEs and the eNB (i.e., therefore having different SINR values) and different numbers of UEs. The test consists on checking that the obtained throughput performance is equal among users and matches a reference throughput value obtained according to the SINR perceived within a given tolerance.

The test vector is obtained according to the values of transport block size reported in table 7.1.7.2.1-1 of [TS36213], considering an equal distribution of the physical resource block among the users using Resource Allocation Type 0 as defined in Section 7.1.6.1 of [TS36213]. Let  $\tau$  be the TTI duration,  $N$  be the number of UEs,  $B$  the transmission bandwidth configuration in number of RBs,  $G$  the RBG size,  $M$  the modulation and coding scheme in use at the given SINR and  $S(M, B)$  be the transport block size in bits as defined by 3GPP TS 36.213. We first calculate the number  $L$  of RBGs allocated to each user as

$$L = \left\lfloor \frac{B}{NG} \right\rfloor$$

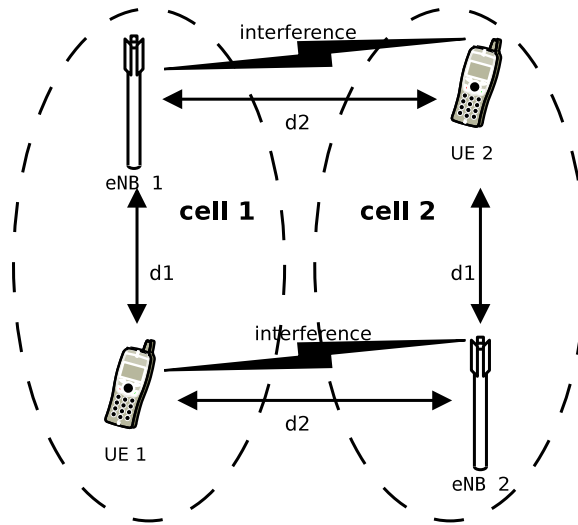

Figure 16.29: Topology for the inter-cell interference test

The reference throughput  $T$  in bit/s achieved by each UE is then calculated as

$$T = \frac{S(M, LG)}{8 \tau}$$

The test passes if the measured throughput matches with the reference throughput within a relative tolerance of 0.1. This tolerance is needed to account for the transient behavior at the beginning of the simulation (e.g., CQI feedback is only available after a few subframes) as well as for the accuracy of the estimator of the average throughput performance over the chosen simulation time (0.4s). This choice of the simulation time is justified by the need to follow the ns-3 guidelines of keeping the total execution time of the test suite low, in spite of the high number of test cases. In any case, we note that a lower value of the tolerance can be used when longer simulations are run.

In Figure [fig-lenaThrTestCase1](#), the curves labeled “RR” represent the test values calculated for the RR scheduler test, as a function of the number of UEs and of the MCS index being used in each test case.

### Proportional Fair scheduler performance

The test suite `lte-pf-ff-mac-scheduler` creates different test cases with a single eNB, using the Proportional Fair (PF) scheduler, and several UEs, all having the same Radio Bearer specification. The test cases are grouped in two categories in order to evaluate the performance both in terms of the adaptation to the channel condition and from a fairness perspective.

In the first category of test cases, the UEs are all placed at the same distance from the eNB, and hence all placed in order to have the same SINR. Different test cases are implemented by using a different SINR value and a different number of UEs. The test consists on checking that the obtained throughput performance matches with the known reference throughput up to a given tolerance. The expected behavior of the PF scheduler when all UEs have the same SNR is that each UE should get an equal fraction of the throughput obtainable by a single UE when using all the resources. We calculate the reference throughput value by dividing the throughput achievable by a single UE at the given SNR by the total number of UEs. Let  $\tau$  be the TTI duration,  $B$  the transmission bandwidth configuration in number of RBs,  $M$  the modulation and coding scheme in use at the given SINR and  $S(M, B)$  be the transport block size as defined in [TS36213]. The reference throughput  $T$  in bit/s achieved by each UE is calculated as

$$T = \frac{S(M, B)}{\tau N}$$

The curves labeled “PF” in Figure [fig-lenaThrTestCase1](#) represent the test values calculated for the PF scheduler tests of the first category, that we just described.

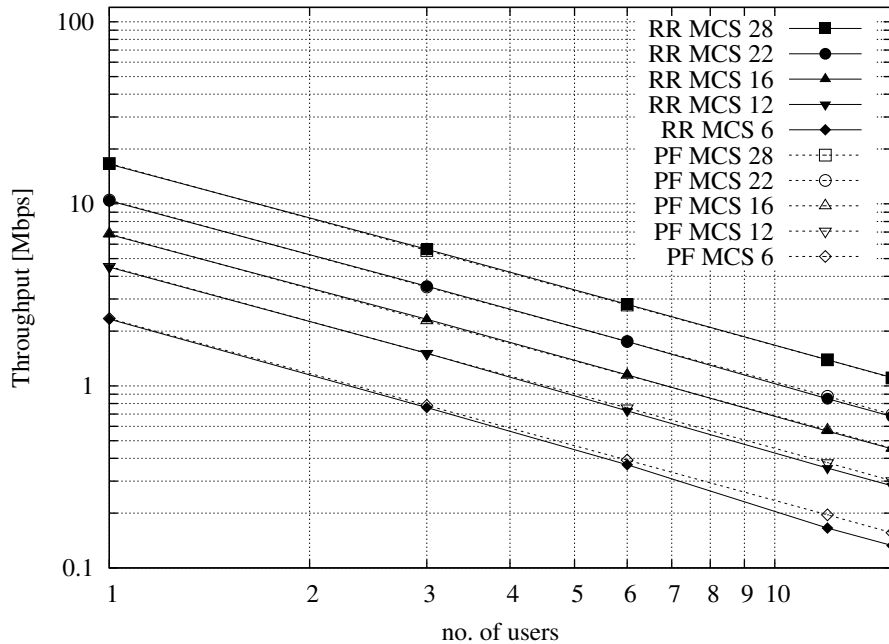

Figure 16.30: Test vectors for the RR and PF Scheduler in the downlink in a scenario where all UEs use the same MCS.

The second category of tests aims at verifying the fairness of the PF scheduler in a more realistic simulation scenario where the UEs have a different SINR (constant for the whole simulation). In these conditions, the PF scheduler will give to each user a share of the system bandwidth that is proportional to the capacity achievable by a single user alone considered its SINR. In detail, let  $M_i$  be the modulation and coding scheme being used by each UE (which is a deterministic function of the SINR of the UE, and is hence known in this scenario). Based on the MCS, we determine the achievable rate  $R_i$  for each user  $i$  using the procedure described in Section-ref{sec:pf}. We then define the achievable rate ratio  $\rho_{R,i}$  of each user  $i$  as

$$\rho_{R,i} = \frac{R_i}{\sum_{j=1}^N R_j}$$

Let now  $T_i$  be the throughput actually achieved by the UE  $i$ , which is obtained as part of the simulation output. We define the obtained throughput ratio  $\rho_{T,i}$  of UE  $i$  as

$$\rho_{T,i} = \frac{T_i}{\sum_{j=1}^N T_j}$$

The test consists of checking that the following condition is verified:

$$\rho_{R,i} = \rho_{T,i}$$

if so, it means that the throughput obtained by each UE over the whole simulation matches with the steady-state throughput expected by the PF scheduler according to the theory. This test can be derived from [Holtzman2000] as follows. From Section 3 of [Holtzman2000], we know that

$$\frac{T_i}{R_i} = c, \forall i$$

where  $c$  is a constant. By substituting the above into the definition of  $\rho_{T,i}$  given previously, we get

$$\begin{aligned} \frac{T_i}{\sum_{j=1}^N T_j} &= \frac{cR_i}{\sum_{j=1}^N cR_j} \\ &= \frac{cR_i}{c \sum_{j=1}^N R_j} \\ &= \frac{R_i}{\sum_{j=1}^N R_j} \end{aligned}$$

which is exactly the expression being used in the test.

Figure *Throughput ratio evaluation for the PF scheduler in a scenario where the UEs have MCS index* presents the results obtained in a test case with UEs  $i = 1, \dots, 5$  that are located at a distance from the base station such that they will use respectively the MCS index 28, 24, 16, 12, 6. From the figure, we note that, as expected, the obtained throughput is proportional to the achievable rate. In other words, the PF scheduler assign more resources to the users that use a higher MCS index.

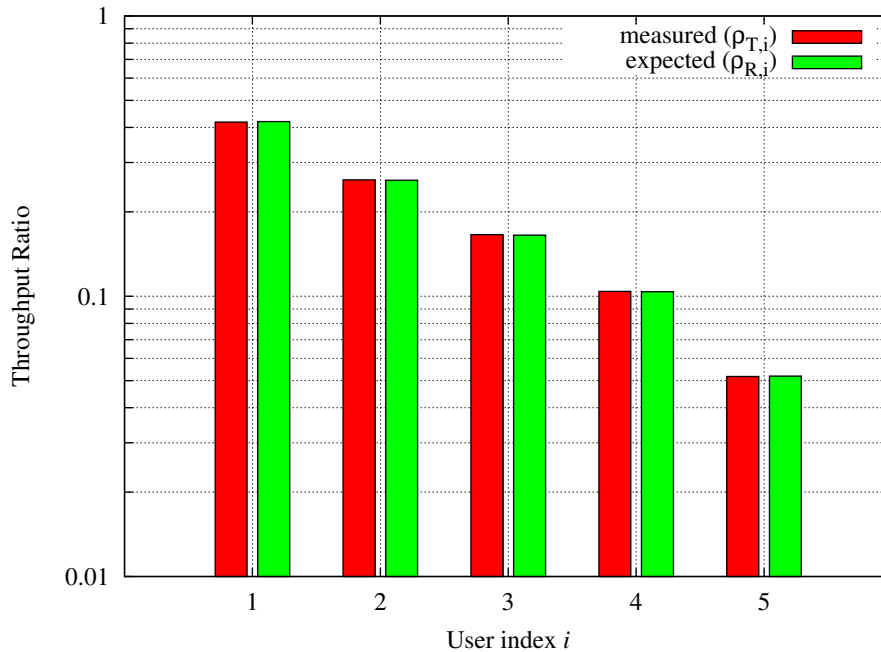

Figure 16.31: Throughput ratio evaluation for the PF scheduler in a scenario where the UEs have MCS index 28, 24, 16, 12, 6

### Building Propagation Loss Model

The aim of the system test is to verify the integration of the BuildingPathlossModel with the lte module. The test exploits a set of three pre calculated losses for generating the expected SINR at the receiver counting the transmission and the noise powers. These SINR values are compared with the results obtained from a LTE simulation that uses the BuildingPathlossModel. The reference loss values are calculated off-line with an Octave script (/test/reference/lte\_pathloss.m). Each test case passes if the reference loss value is equal to the value calculated by the simulator within a tolerance of 0.001 dB, which accounts for numerical errors in the calculations.

## Physical Error Model

The test suite `lte-test-phy-error-model` generates nine test cases with single eNB and a various number of UEs, all having the same Radio Bearer specification. Each test is designed for evaluating the error rate perceived by a specific TB size in order to verify that it corresponds to the expected values according to the BLER generated for CB size analog to the TB size. This means that, for instance, the test will check that the performance of a TB of  $N$  bits is analogous to the one of a CB size of  $N$  bits by collecting the performance of a user which has been forced the generation of a such TB size according to the distance to eNB. In order to significantly test the BER at MAC level, we modified the Adaptive Modulation and Coding (AMC) module, the `LteAmc` class, for making it less robust to channel conditions by adding a configurable BER parameter (called `Ber` in the ns3 attribute system) which enable the selection of the desired BER at MAC level when choosing the MCS to be used. In detail, the AMC module has been forced to select the AMC considering a BER of 0.01 (instead of the standard value equal to 0.00005). We note that, these values do not reflect actual BER since they come from an analytical bound which do not consider all the transmission chain aspects; therefore the resulted BER might be different.

The parameters of the nine test cases are reported in the following:

1. 4 UEs placed 1800 meters far from the eNB, which implies the use of MCS 2 (SINR of -5.51 dB) and a TB of 256 bits, that in turns produce a BER of 0.33 (see point A in figure *BLER for tests 1, 2, 3.*).
2. 2 UEs placed 1800 meters far from the eNB, which implies the use of MCS 2 (SINR of -5.51 dB) and a TB of 528 bits, that in turns produce a BER of 0.11 (see point B in figure *BLER for tests 1, 2, 3.*).
3. 1 UE placed 1800 meters far from the eNB, which implies the use of MCS 2 (SINR of -5.51 dB) and a TB of 1088 bits, that in turns produce a BER of 0.02 (see point C in figure *BLER for tests 1, 2, 3.*).
4. 1 UE placed 600 meters far from the eNB, which implies the use of MCS 12 (SINR of 4.43 dB) and a TB of 4800 bits, that in turns produce a BER of 0.3 (see point D in figure *BLER for tests 4, 5.*).
5. 3 UEs placed 600 meters far from the eNB, which implies the use of MCS 12 (SINR of 4.43 dB) and a TB of 1632 bits, that in turns produce a BER of 0.55 (see point E in figure *BLER for tests 4, 5.*).
6. 1 UE placed 470 meters far from the eNB, which implies the use of MCS 16 (SINR of 8.48 dB) and a TB of 7272 bits (segmented in 2 CBs of 3648 and 3584 bits), that in turns produce a BER of 0.14, since each CB has CBLER equal to 0.075 (see point F in figure *BLER for test 6.*).

The test verifies that in each case the obtained number of packets received correctly falls within the 99.9% confidence interval (CI) of a Binomial distribution where the parameter  $p$  is equal to  $1 - BER$ , the parameter  $n$  is the total number of packets sent and the parameter  $k$  is the number of packets correctly received. The value of the CI has been chosen for guaranteeing a sufficient margin on the errors due to the quantization of the MI values in the tables.

## MIMO Model

The test suite `lte-mimo` aims at verifying both the effect of the gain considered for each Transmission Mode on the system performance and the Transmission Mode switching through the scheduler interface. The test consists on checking whether the amount of bytes received during a certain window of time (0.1 seconds in our case) corresponds to the expected ones according to the values of transport block size reported in table 7.1.7.2.1-1 of [TS36213], similarly to what done for the tests of the schedulers.

The test is performed both for Round Robin and Proportional Fair schedulers. The test passes if the measured throughput matches with the reference throughput within a relative tolerance of 0.1. This tolerance is needed to account for the transient behavior at the beginning of the simulation and the transition phase between the Transmission Modes.



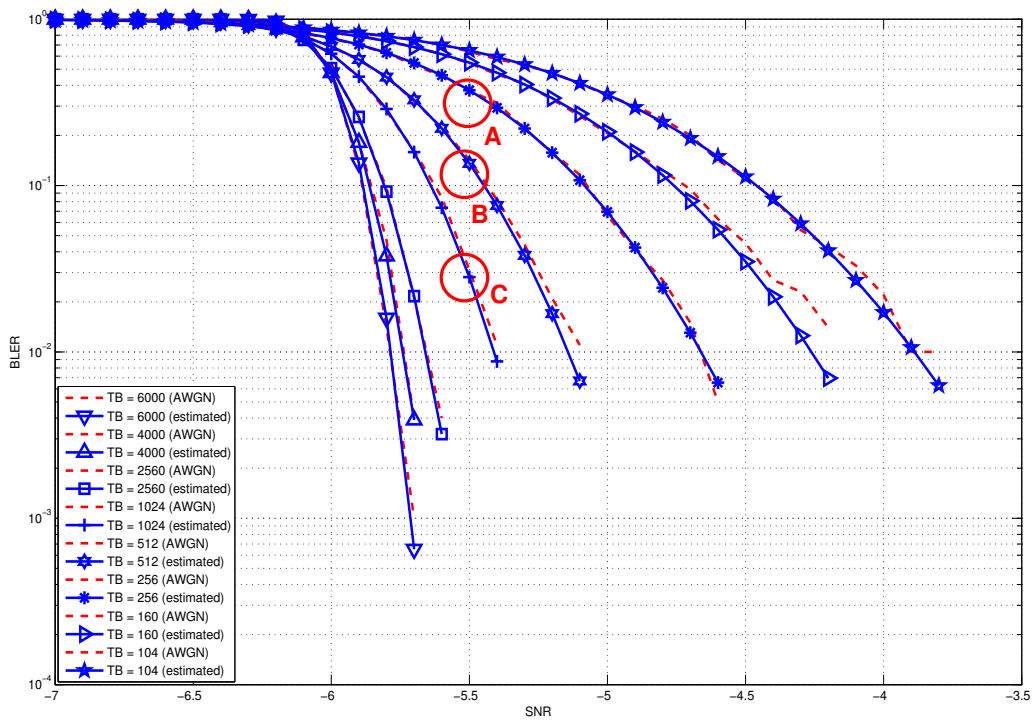

Figure 16.32: BLER for tests 1, 2, 3.

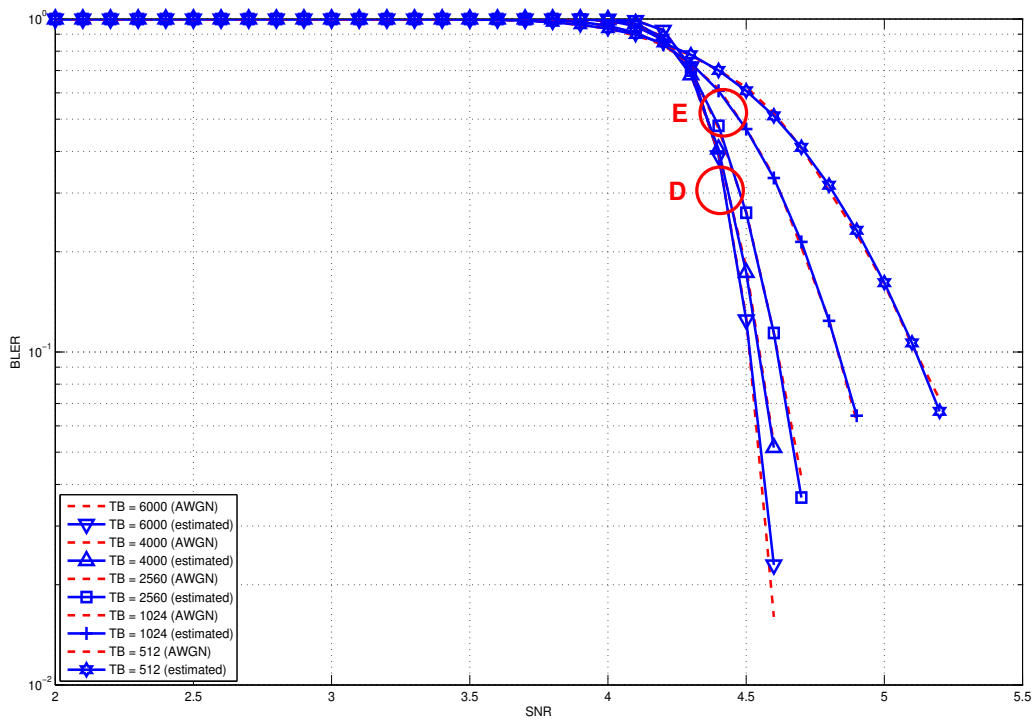

Figure 16.33: BLER for tests 4, 5.

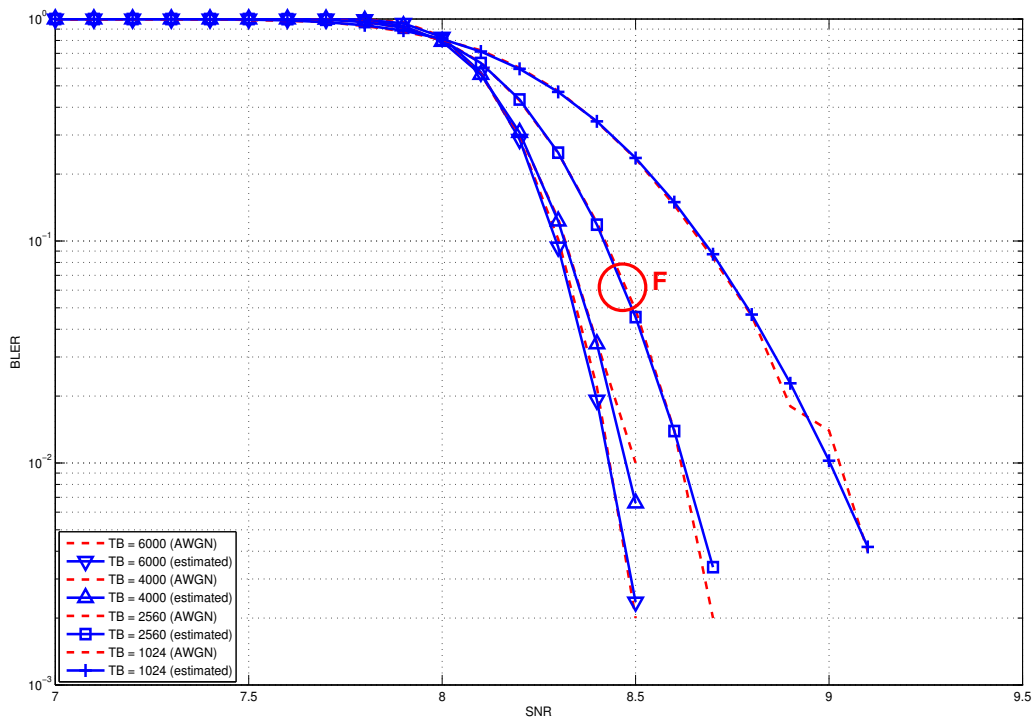

Figure 16.34: BLER for test 6.

### Antenna Model integration

The test suite *lte-antenna* checks that the AntennaModel integrated with the LTE model works correctly. This test suite recreates a simulation scenario with one eNB node at coordinates (0,0,0) and one UE node at coordinates (x,y,0). The eNB node is configured with an CosineAntennaModel having given orientation and beamwidth. The UE instead uses the default IsotropicAntennaModel. The test checks that the received power both in uplink and downlink account for the correct value of the antenna gain, which is determined offline; this is implemented by comparing the uplink and downlink SINR and checking that both match with the reference value up to a tolerance of  $10^{-6}$  which accounts for numerical errors. Different test cases are provided by varying the x and y coordinates of the UE, and the beamwidth and the orientation of the antenna of the eNB.

### RLC

Two test suites *lte-rlc-um-transmitter* and *lte-rlc-am-transmitter* check that the UM RLC and the AM RLC implementation work correctly. Both these suites work by testing RLC instances connected to special test entities that play the role of the MAC and of the PDCP, implementing respectively the *LteMacSapProvider* and *LteRlcSapUser* interfaces. Different test cases (i.e., input test vector consisting of series of primitive calls by the MAC and the PDCP) are provided that check the behavior in the following cases:

1. one SDU, one PDU: the MAC notifies a TX opportunity causes the creation of a PDU which exactly contains a whole SDU
2. segmentation: the MAC notifies multiple TX opportunities that are smaller than the SDU size stored in the transmission buffer, which is then to be fragmented and hence multiple PDUs are generated;
3. concatenation: the MAC notifies a TX opportunity that is bigger than the SDU, hence multiple SDUs are concatenated in the same PDU
4. buffer status report: a series of new SDUs notifications by the PDCP is interleaved with a series of TX opportunity notification in order to verify that the buffer status report procedure is correct.

In all these cases, an output test vector is determine manually from knowledge of the input test vector and knowledge of the expected behavior. These test vector are specialized for UM RLC and AM RLC due to their different behavior. Each test case passes if the sequence of primitives triggered by the RLC instance being tested is exactly equal to the output test vector. In particular, for each PDU transmitted by the RLC instance, both the size and the content of the PDU are verified to check for an exact match with the test vector.

### GTP-U protocol

The unit test suite *epc-gtpu* checks that the encoding and decoding of the GTP-U header is done correctly. The test fills in a header with a set of known values, adds the header to a packet, and then removes the header from the packet. The test fails if, upon removing, any of the fields in the GTP-U header is not decoded correctly. This is detected by comparing the decoded value from the known value.

### S1-U interface

Two test suites (*epc-slu-uplink* and *epc-slu-downlink*) make sure that the S1-U interface implementation works correctly in isolation. This is achieved by creating a set of simulation scenarios where the EPC model alone is used, without the LTE model (i.e., without the LTE radio protocol stack, which is replaced by simple CSMA devices). This checks that the interoperation between multiple *EpcEnbApplication* instances in multiple eNBs and the *EpcSgwPgwApplication* instance in the SGW/PGW node works correctly in a variety of scenarios, with varying numbers of end users (nodes with a CSMA device installed), eNBs, and different traffic patterns (packet sizes and number of total packets). Each test case works by injecting the chosen traffic pattern in the network (at the considered

UE or at the remote host for in the uplink or the downlink test suite respectively) and checking that at the receiver (the remote host or each considered UE, respectively) that exactly the same traffic patterns is received. If any mismatch in the transmitted and received traffic pattern is detected for any UE, the test fails.

### TFT classifier

The test suite `epc-tft-classifier` checks in isolation that the behavior of the `EpcTftClassifier` class is correct. This is performed by creating different classifier instances where different TFT instances are activated, and testing for each classifier that an heterogeneous set of packets (including IP and TCP/UDP headers) is classified correctly. Several test cases are provided that check the different matching aspects of a TFT (e.g. local/remote IP address, local/remote port) both for uplink and downlink traffic. Each test case corresponds to a specific packet and a specific classifier instance with a given set of TFTs. The test case passes if the bearer identifier returned by the classifier exactly matches with the one that is expected for the considered packet.

### End-to-end LTE-EPC data plane functionality

The test suite `lte-epc-e2e-data` ensures the correct end-to-end functionality of the LTE-EPC data plane. For each test case in this suite, a complete LTE-EPC simulation scenario is created with the following characteristics:

- a given number of eNBs
- for each eNB, a given number of UEs
- for each UE, a given number of active EPS bearers
- for each active EPS bearer, a given traffic pattern (number of UDP packets to be transmitted and packet size)

Each test is executed by transmitting the given traffic pattern both in the uplink and in the downlink, at subsequent time intervals. The test passes if all the following conditions are satisfied:

- for each active EPS bearer, the transmitted and received traffic pattern (respectively at the UE and the remote host for uplink, and vice versa for downlink) is exactly the same
- for each active EPS bearer and each direction (uplink or downlink), exactly the expected number of packet flows over the corresponding RadioBearer instance

## 16.4 Profiling Documentation

### 16.4.1 Overview and objectives

The main objective of the profiling carried out is to assess the simulator performance on a broad set of scenarios. This evaluation provides reference values for simulation running times and memory consumption figures. It also helps to identify potential performance improvements and to check for scalability problems when increasing the number of eNodeB and UEs attached to those.

In the following sections, a detailed description of the general profiling framework employed to perform the study is introduced. It also includes details on the main performed tests and its results evaluation.

## 16.4.2 Framework description

### Simulation scripts

The simulation script used for all the E-UTRAN results showed in this documentation is located at `src/lte/examples/lena-profiling.cc`. It uses the complete PHY and MAC UE/eNodeB implementation with a simplified RLC implementation on top. This script generates a squared grid topology, placing a eNodeB at the centre of each square. UEs attached to this node are scattered randomly across the square (using a random uniform distribution along X and Y axis). If *BuildingPropagationModel* is used, the squares are replaced by rooms. To generate the UL and DL traffic, the RLC implementation always report data to be transferred.

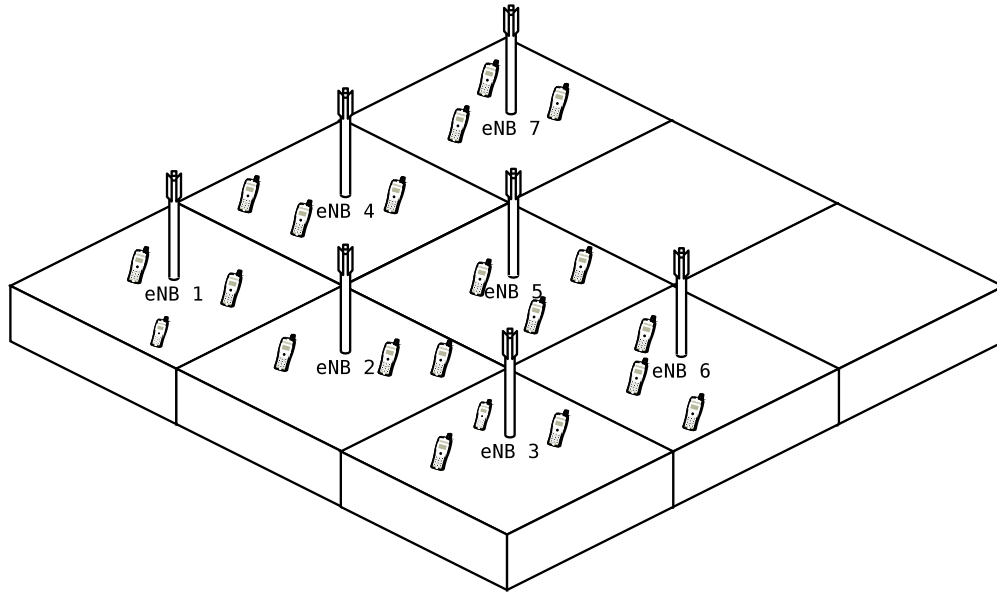

Figure 16.35: E-UTRAN

For the EPC results, the script is `src/lte/examples/lena-simple-epc.cc`. It uses a complete E-UTRAN implementation (PHY+MAC+RLC/UM+PDCP) and the most relevant EPC user plane entities the PGW and SGW, including GTP-U tunneling. This script generates a given number of eNodeBs, distributed across a line and attaches a single UE to every eNodeB. It also creates an EPC network and an external host connected to it through the Internet. Each UE sends and receives data to and from the remote host. In addition, each UE is also sending data to the UE camped in the adjacent eNodeB.

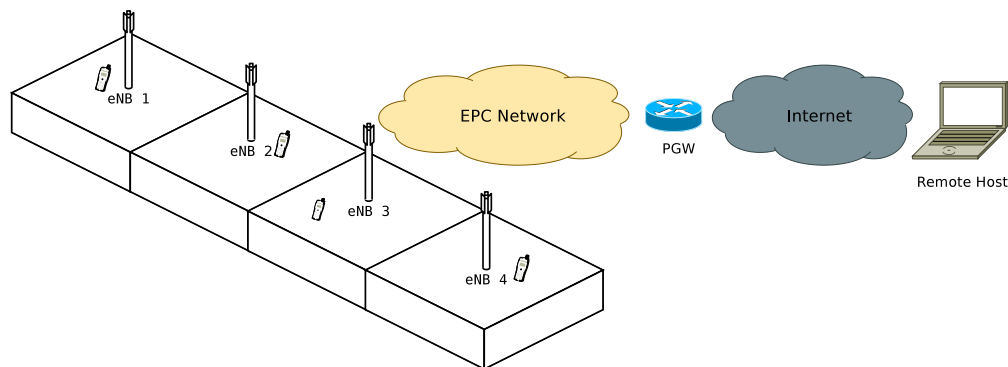

Figure 16.36: Propagation Model

RLC and MAC traces are enabled for all UEs and all eNodeBs and those traces are written to disk directly. The MAC scheduler used is *round robin*.

### Simulation input parameters

The *lena-profiling* simulation script accepts the following input parameters:

- `simTime`: time to simulate (in seconds)
- `nUe`: number of UEs attached to each eNodeB
- `nEnb`: number of eNodeB composing the grid per floor
- `nFloors`: number of floors, 0 for *Friis propagation model* (no walls), 1 or greater for *Building propagation model* generating a nFloors-storey building.
- `traceDirectory`: destination directory where simulation traces will be stored

The *lena-simple-epc* script accepts those other parameters:

- `simTime`: time to simulate (in seconds)
- `numberOfNodes`: number of eNodeB + UE pairs created

### Time measurement

Running time is measured using default Linux shell command `time`. This command counts how much user time the execution of a program takes.

### Perl script

To simplify the process of running the profiling script for a wide range of values and collecting its timing data, a simple Perl script to automate the complete process is provided. It is placed in `src/lte/test/lte-test-run-time.pl` for *lena-profiling* and in `src/lte/epc-test-run-time.pl` for *lena-simple-epc*. It simply runs a batch of simulations with a range of parameters and stores the timing results in a CSV file called *times.csv* and *epcTimes.csv* respectively. The range of values each parameter sweeps can be modified editing the corresponding script.

### Requirements

The following Perl modules are required to use the provided script, all of them available from CPAN: `* IO::CaptureOutput * Statistics::Descriptive * Cwd`

### Reference software and equipment

All timing tests had been run in a Intel Pentium IV 3.00 GHz machine with 512 Mb of RAM memory running Fedora Core 10 with a 2.6.27.41-170.2.117 kernel, storing the traces directly to the hard disk.

Also, as a reference configuration, the build has been configured static and optimized. The exact `waf` command issued is:

```
CXXFLAGS="-O3 -w" ./waf -d optimized configure --enable-static
--enable-examples --enable-modules=lte
```

## 16.4.3 Results

### E-UTRAN

The following results and figures had been obtained with LENA **changeset 2c5b0d697717**.

#### Running time

This scenario, evaluates the running time for a fixed simulation time (10s) and Friis propagation mode increasing the number of UEs attached to each eNodeB and the number of planted eNodeBs in the scenario.

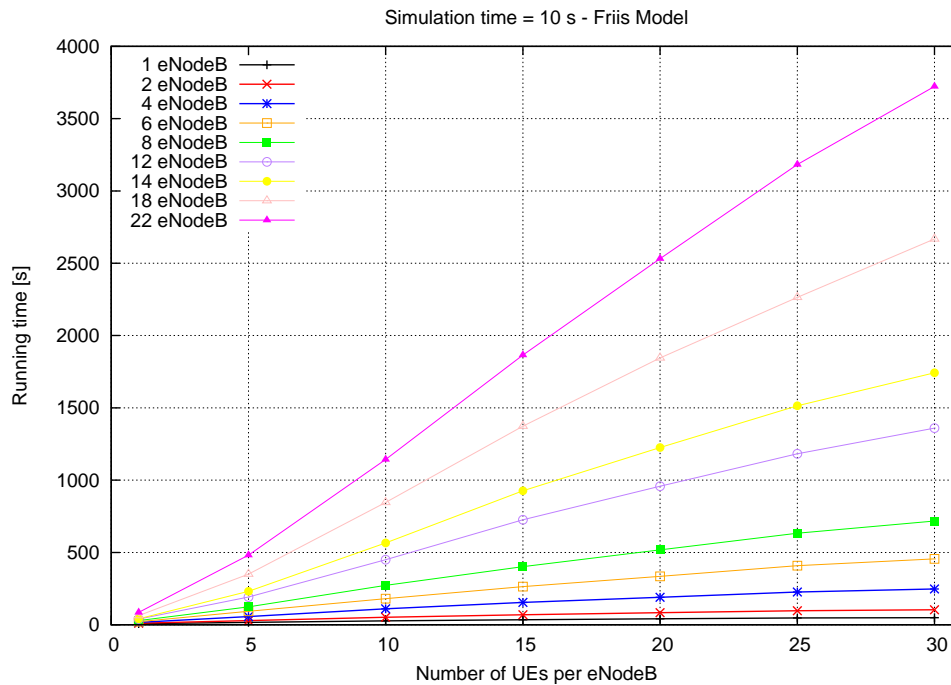

Figure 16.37: Running time

The figure shows the expected behaviour, since it increases linearly respect the number of UEs per eNodeB and quadratically respect the total number of eNodeBs.

#### Propagation model

The objective of this scenario is to evaluate the impact of the propagation model complexity in the overall run time figures. Therefore, the same scenario is simulated twice: once using the more simple Friis model, once with the more complex Building model. The rest of the parameters (e.g. number of eNodeB and of UE attached per eNodeB) were maintained. The timing results for both models are compared in the following figure.

In this situation, results are also coherent with what is expected. The more complex the model, the higher the running time. Moreover, as the number of computed path losses increases (i.e. more UEs per eNodeB or more eNodeBs) the extra complexity of the propagation model drives the running time figures further apart.



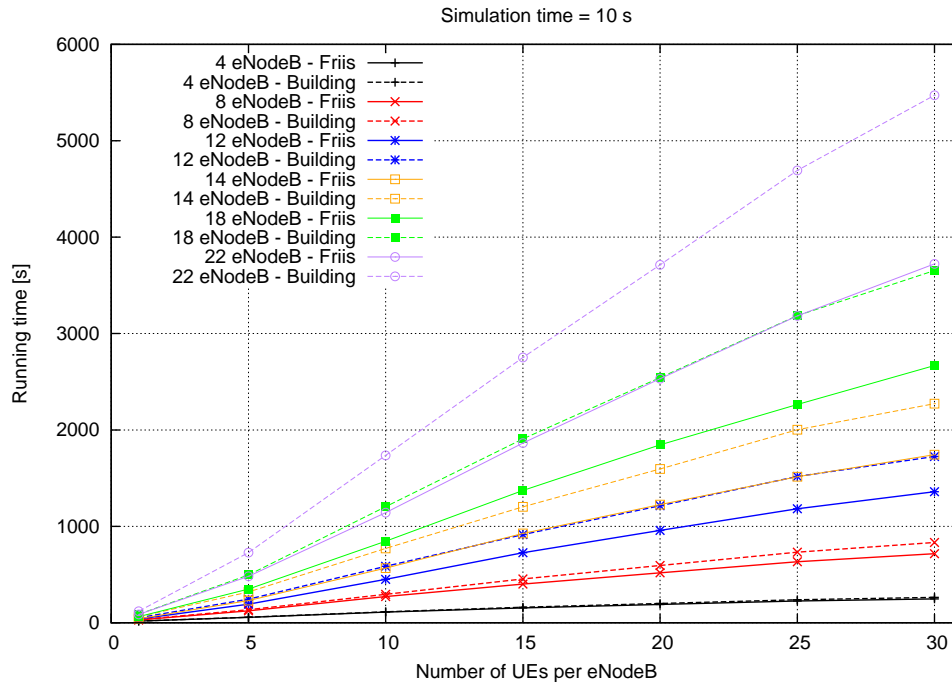

Figure 16.38: Propagation Model

### Simulation time

In this scenario, for a fixed set of UEs per eNodeB, different simulation times had been run. As the simulation time increases, running time should also increase linearly, i.e. for a given scenario, simulate four seconds should take twice times what it takes to simulate two seconds. The slope of this line is a function of the complexity of the scenario: the more eNodeB / UEs placed, the higher the slope of the line.

### Memory usage

Massif tool to profile memory consumption

### EPC

The following results and figures had been obtained with LENA **changeset e8b3ccdf6673**. The rationale behind the two scenarios profiled on this section is the same than for the E-UTRA part.

### Running time

Running time evolution is quadratic since we increase at the same time the number of eNodeB and the number of UEs.

To estimate the additional complexity of the upper LTE Radio Protocol Stack model and the EPC model, we compare two scenarios using the simplified E-UTRAN version (using only PHY, MAC and the simplified RLC/SM, with no EPC and no ns-3 applications) against the complete E-UTRAN + EPC (with UM RLC, PDCP, end-to-end IP networking and regular ns-3 applications). Both configuration have been tested with the same number of UEs per eNodeB, the

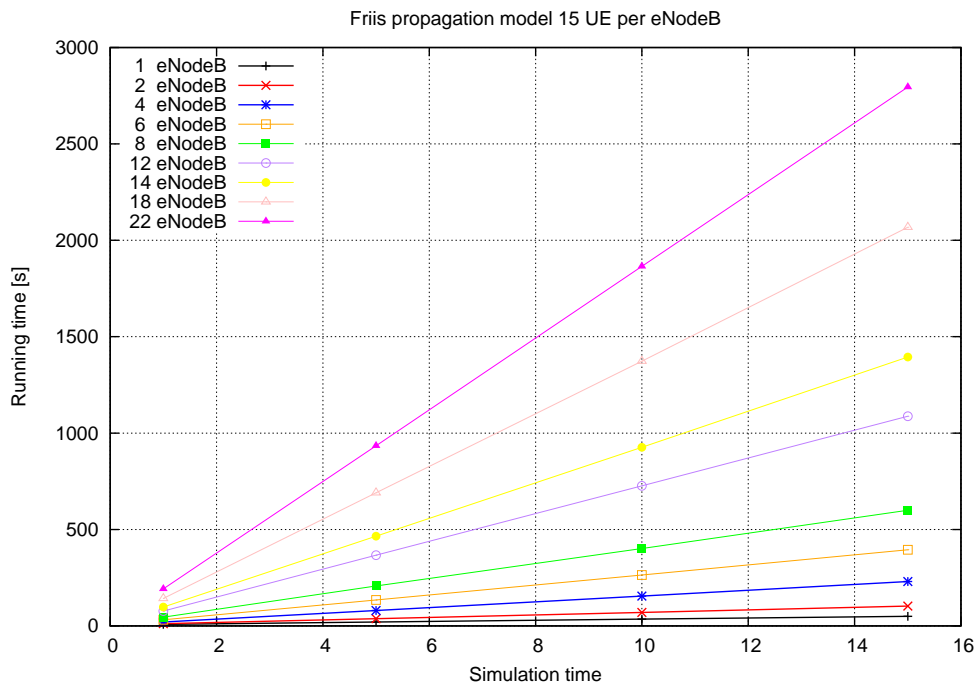

Figure 16.39: Simulation time

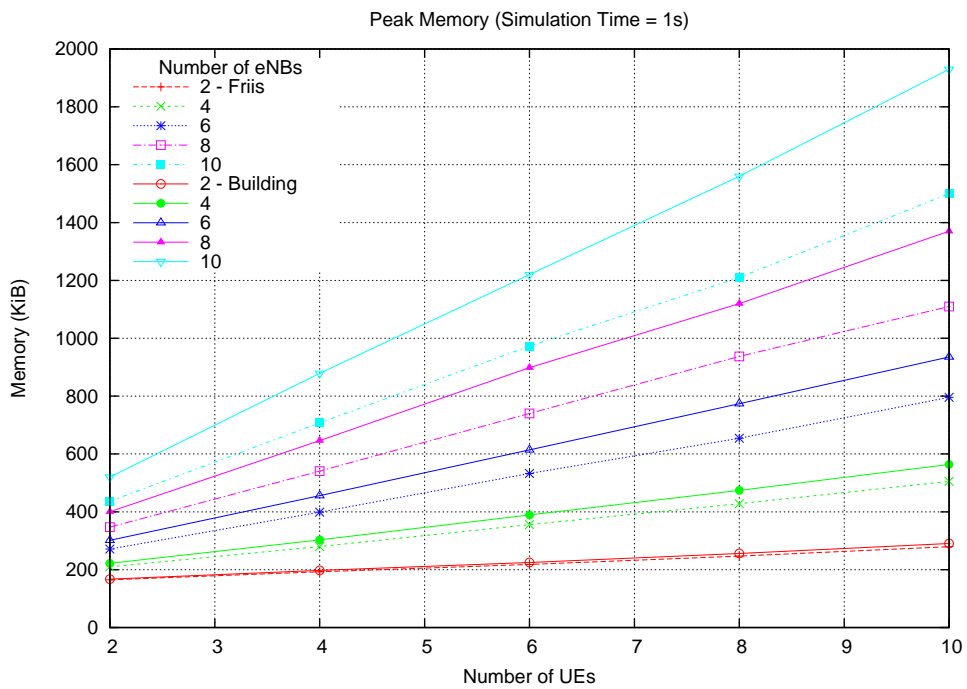

Figure 16.40: Memory profile

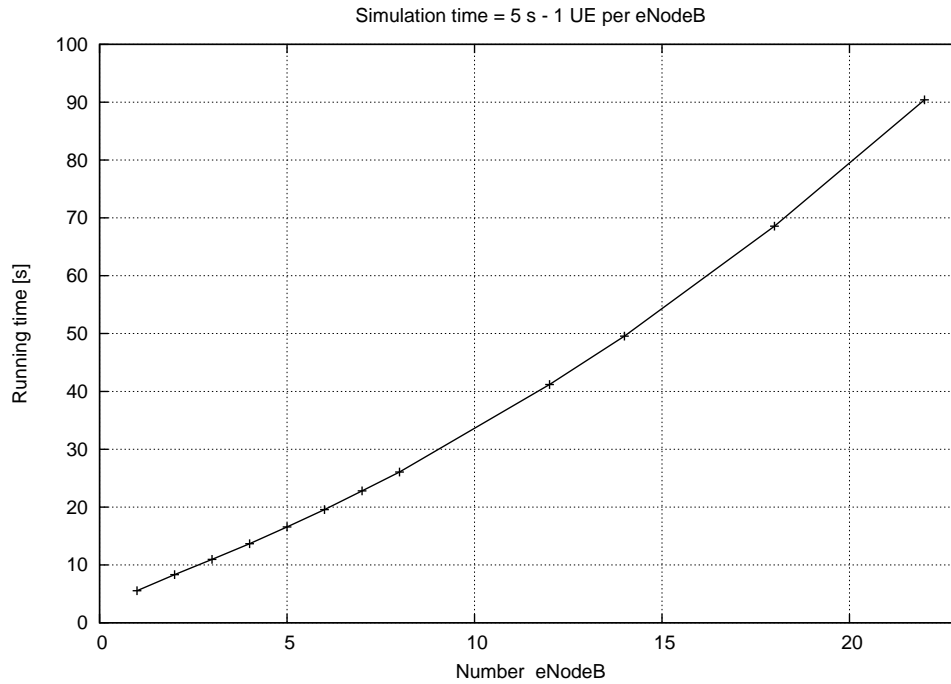

Figure 16.41: Running time

same number of eNodeBs, and approximately the same volume of transmitted data (an exact match was not possible due to the different ways in which packets are generated in the two configurations).

From the figure, it is evident that the additional complexity of using the upper LTE stack plus the EPC model translates approximately into a doubling of the execution time of the simulations. We believe that, considered all the new features that have been added, this figure is acceptable.

### Simulation time

Finally, again the linearity of the running time as the simulation time increases gets validated through a set of experiments, as the following figure shows.

## 16.5 References

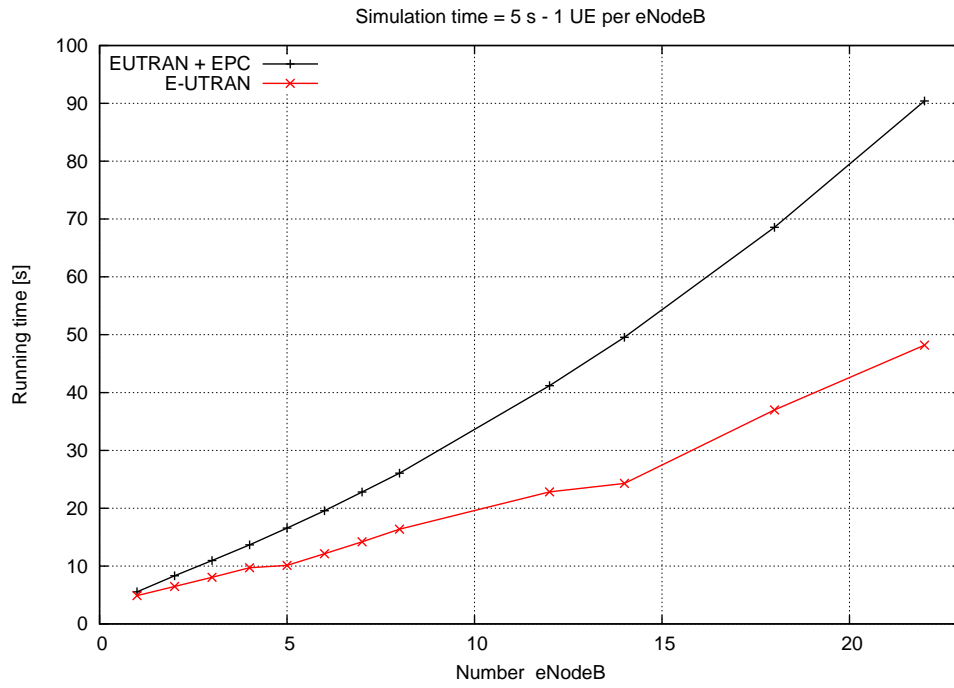

Figure 16.42: EPC E-UTRAN running time

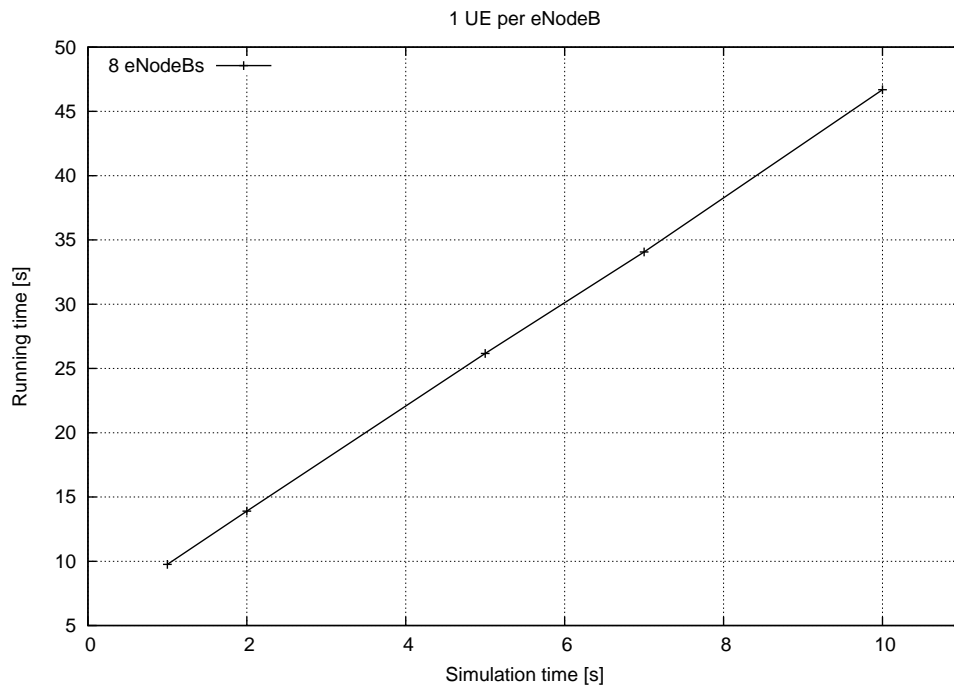

Figure 16.43: Simulation time

# MESH NETDEVICE

*Placeholder chapter*

The Mesh NetDevice based on 802.11s was added in *ns-3.6*. An overview presentation by Kirill Andreev was published at the wns-3 workshop in 2009: <http://www.nsnam.org/wiki/index.php/Wns3-2009>.



# MPI FOR DISTRIBUTED SIMULATION

Parallel and distributed discrete event simulation allows the execution of a single simulation program on multiple processors. By splitting up the simulation into logical processes, LPs, each LP can be executed by a different processor. This simulation methodology enables very large-scale simulations by leveraging increased processing power and memory availability. In order to ensure proper execution of a distributed simulation, message passing between LPs is required. To support distributed simulation in *ns-3*, the standard Message Passing Interface (MPI) is used, along with a new distributed simulator class. Currently, dividing a simulation for distributed purposes in *ns-3* can only occur across point-to-point links.

## 18.1 Current Implementation Details

During the course of a distributed simulation, many packets must cross simulator boundaries. In other words, a packet that originated on one LP is destined for a different LP, and in order to make this transition, a message containing the packet contents must be sent to the remote LP. Upon receiving this message, the remote LP can rebuild the packet and proceed as normal. The process of sending and receiving messages between LPs is handled easily by the new MPI interface in *ns-3*.

Along with simple message passing between LPs, a distributed simulator is used on each LP to determine which events to process. It is important to process events in time-stamped order to ensure proper simulation execution. If a LP receives a message containing an event from the past, clearly this is an issue, since this event could change other events which have already been executed. To address this problem, a conservative synchronization algorithm with lookahead is used in *ns-3*. For more information on different synchronization approaches and parallel and distributed simulation in general, please refer to “Parallel and Distributed Simulation Systems” by Richard Fujimoto.

### 18.1.1 Remote point-to-point links

As described in the introduction, dividing a simulation for distributed purposes in *ns-3* currently can only occur across point-to-point links; therefore, the idea of remote point-to-point links is very important for distributed simulation in *ns-3*. When a point-to-point link is installed, connecting two nodes, the point-to-point helper checks the system id, or rank, of both nodes. The rank should be assigned during node creation for distributed simulation and is intended to signify on which LP a node belongs. If the two nodes are on the same rank, a regular point-to-point link is created. If, however, the two nodes are on different ranks, then these nodes are intended for different LPs, and a remote point-to-point link is used. If a packet is to be sent across a remote point-to-point link, MPI is used to send the message to the remote LP.

## 18.1.2 Distributing the topology

Currently, the full topology is created on each rank, regardless of the individual node system ids. Only the applications are specific to a rank. For example, consider node 1 on LP 1 and node 2 on LP 2, with a traffic generator on node 1. Both node 1 and node 2 will be created on both LP1 and LP2; however, the traffic generator will only be installed on LP1. While this is not optimal for memory efficiency, it does simplify routing, since all current routing implementations in *ns-3* will work with distributed simulation.

## 18.2 Running Distributed Simulations

### 18.2.1 Prerequisites

Ensure that MPI is installed, as well as `mpic++`. In Ubuntu repositories, these are `openmpi-bin`, `openmpi-common`, `openmpi-doc`, `libopenmpi-dev`. In Fedora, these are `openmpi` and `openmpi-devel`.

Note:

There is a conflict on some Fedora systems between `libotf` and `openmpi`. A possible “quick-fix” is to `yum remove libotf` before installing `openmpi`. This will remove conflict, but it will also remove `emacs`. Alternatively, these steps could be followed to resolve the conflict::

1) Rename the tiny `otfdump` which `emacs` says it needs:

```
mv /usr/bin/otfdump /usr/bin/otfdump.emacs-version
```

2) Manually resolve `openmpi` dependencies:

```
sudo yum install libgfortran libtorque numactl
```

3) Download rpm packages:

```
openmpi-1.3.1-1.fc11.i586.rpm
openmpi-devel-1.3.1-1.fc11.i586.rpm
openmpi-libs-1.3.1-1.fc11.i586.rpm
openmpi-vt-1.3.1-1.fc11.i586.rpm
```

from

```
http://mirrors.kernel.org/fedora/releases/11/Everything/i386/os/Packages/
```

4) Force the packages in:

```
sudo rpm -ivh --force openmpi-1.3.1-1.fc11.i586.rpm
openmpi-libs-1.3.1-1.fc11.i586.rpm openmpi-devel-1.3.1-1.fc11.i586.rpm
openmpi-vt-1.3.1-1.fc11.i586.rpm
```

Also, it may be necessary to add the `openmpi bin` directory to `PATH` in order to execute `mpic++` and `mpirun` from the command line. Alternatively, the full path to these executables can be used. Finally, if `openmpi` complains about the inability to open shared libraries, such as `libmpi_cxx.so.0`, it may be necessary to add the `openmpi lib` directory to `LD_LIBRARY_PATH`.

Here is an example of setting up `PATH` and `LD_LIBRARY_PATH` using a bash shell::

For a 32-bit Linux distribution:

```
export PATH=$PATH:/usr/lib/openmpi/bin
```



```
export LD_LIBRARY_PATH=$LD_LIBRARY_PATH:/usr/lib/openmpi/lib
```

For a 64-bit Linux distribution:

```
export PATH=$PATH:/usr/lib64/openmpi/bin
export LD_LIBRARY_PATH=$LD_LIBRARY_PATH:/usr/lib64/openmpi/lib
```

These lines can be added into `~/.bash_profile` or `~/.bashrc` to avoid having to retype them when a new shell is opened.

## 18.2.2 Building and Running Examples

If you already built *ns-3* without MPI enabled, you must re-build::

```
./waf distclean
```

Configure *ns-3* with the `--enable-mpi` option::

```
./waf -d debug configure --enable-examples --enable-tests --enable-mpi
```

Ensure that MPI is enabled by checking the optional features shown from the output of configure.

Next, build *ns-3*::

```
./waf
```

After building *ns-3* with mpi enabled, the example programs are now ready to run with `mpirun`. Here are a few examples (from the root *ns-3* directory)::

```
mpirun -np 2 ./waf --run simple-distributed
mpirun -np 4 -machinefile mpihosts ./waf --run 'nms-udp-nix --LAN=2 --CN=4 --nix=1'
```

The `np` switch is the number of logical processors to use. The `machinefile` switch is which machines to use. In order to use `machinefile`, the target file must exist (in this case `mpihosts`). This can simply contain something like::

```
localhost
localhost
localhost
...
```

Or if you have a cluster of machines, you can name them.

NOTE: Some users have experienced issues using `mpirun` and `waf` together. An alternative way to run distributed examples is shown below::

```
./waf shell
cd build/debug
mpirun -np 2 src/mpi/examples/simple-distributed
```

## 18.2.3 Creating custom topologies

The example programs in `src/mpi/examples` give a good idea of how to create different topologies for distributed simulation. The main points are assigning system ids to individual nodes, creating point-to-point links where the simulation should be divided, and installing applications only on the LP associated with the target node.

Assigning system ids to nodes is simple and can be handled two different ways. First, a `NodeContainer` can be used to create the nodes and assign system ids::

```
NodeContainer nodes;
nodes.Create (5, 1); // Creates 5 nodes with system id 1.
```

Alternatively, nodes can be created individually, assigned system ids, and added to a NodeContainer. This is useful if a NodeContainer holds nodes with different system ids::

```
NodeContainer nodes;
Ptr<Node> node1 = CreateObject<Node> (0); // Create node1 with system id 0
Ptr<Node> node2 = CreateObject<Node> (1); // Create node2 with system id 1
nodes.Add (node1);
nodes.Add (node2);
```

Next, where the simulation is divided is determined by the placement of point-to-point links. If a point-to-point link is created between two nodes with different system ids, a remote point-to-point link is created, as described in *Current Implementation Details*.

Finally, installing applications only on the LP associated with the target node is very important. For example, if a traffic generator is to be placed on node 0, which is on LP0, only LP0 should install this application. This is easily accomplished by first checking the simulator system id, and ensuring that it matches the system id of the target node before installing the application.

## 18.3 Tracing During Distributed Simulations

Depending on the system id (rank) of the simulator, the information traced will be different, since traffic originating on one simulator is not seen by another simulator until it reaches nodes specific to that simulator. The easiest way to keep track of different traces is to just name the trace files or pcaps differently, based on the system id of the simulator. For example, something like this should work well, assuming all of these local variables were previously defined::

```
if (MpiInterface::GetSystemId () == 0)
{
    pointToPoint.EnablePcapAll ("distributed-rank0");
    phy.EnablePcap ("distributed-rank0", apDevices.Get (0));
    csma.EnablePcap ("distributed-rank0", csmaDevices.Get (0), true);
}
else if (MpiInterface::GetSystemId () == 1)
{
    pointToPoint.EnablePcapAll ("distributed-rank1");
    phy.EnablePcap ("distributed-rank1", apDevices.Get (0));
    csma.EnablePcap ("distributed-rank1", csmaDevices.Get (0), true);
}
```

# MOBILITY

The mobility support in ns-3 includes:

- a set of mobility models which are used to track and maintain the *current* cartesian position and speed of an object.
- a “course change notifier” trace source which can be used to register listeners to the course changes of a mobility model
- a number of helper classes which are used to place nodes and setup mobility models (including parsers for some mobility definition formats).

## 19.1 Model Description

The source code for mobility lives in the directory `src/mobility`.

### 19.1.1 Design

The design includes mobility models, position allocators, and helper functions.

In ns-3, special `MobilityModel` objects track the evolution of position with respect to a (cartesian) coordinate system. The mobility model is typically aggregated to an `ns3::Node` object and queried using `GetObject<MobilityModel> ()`. The base class `ns3::MobilityModel` is subclassed for different motion behaviors.

The initial position of objects is typically set with a `PositionAllocator`. These types of objects will lay out the position on a notional canvas. Once the simulation starts, the position allocator may no longer be used, or it may be used to pick future mobility “waypoints” for such mobility models.

Most users interact with the mobility system using mobility helper classes. The `MobilityHelper` combines a mobility model and position allocator, and can be used with a node container to install mobility capability on a set of nodes.

We first describe the coordinate system and issues surrounding multiple coordinate systems.

#### Coordinate system

There are many possible coordinate systems and possible translations between them. ns-3 uses the Cartesian coordinate system only, at present.

The question has arisen as to how to use the mobility models (supporting Cartesian coordinates) with different coordinate systems. This is possible if the user performs conversion between the ns-3 Cartesian and the other coordinate

system. One possible library to assist is the proj4 <http://trac.osgeo.org/proj/> library for projections and reverse projections.

If we support converting between coordinate systems, we must adopt a reference. It has been suggested to use the geocentric Cartesian coordinate system as a reference. Contributions are welcome in this regard.

The question has arisen about adding a new mobility model whose motion is natively implemented in a different coordinate system (such as an orbital mobility model implemented using spherical coordinate system). We advise to create a subclass with the APIs desired (such as `Get/SetSphericalPosition`), and new position allocators, and implement the motion however desired, but must also support the conversion to cartesian (by supporting the cartesian `Get/SetPosition`).

### Coordinates

The base class for a coordinate is called `ns3::Vector`. While positions are normally described as coordinates and not vectors in the literature, it is possible to reuse the same data structure to represent position (x,y,z) and velocity (magnitude and direction from the current position). ns-3 uses class `Vector` for both.

There are also some additional related structures used to support mobility models.

- Rectangle
- Box
- Waypoint

### MobilityModel

Describe base class

- `GetPosition ()`
- Position and Velocity attributes
- `GetDistanceFrom ()`
- `CourseChangeNotification`

### MobilityModel Subclasses

- `ConstantPosition`
- `ConstantVelocity`
- `ConstantAcceleration`
- `GaussMarkov`
- `Hierarchical`
- `RandomDirection2D`
- `RandomWalk2D`
- `RandomWaypoint`
- `SteadyStateRandomWaypoint`
- `Waypoint`

## PositionAllocator

Position allocators usually used only at beginning, to lay out the nodes initial position. However, some mobility models (e.g. RandomWaypoint) will use a position allocator to pick new waypoints.

- ListPositionAllocator
- GridPositionAllocator
- RandomRectanglePositionAllocator
- RandomBoxPositionAllocator
- RandomDiscPositionAllocator
- UniformDiscPositionAllocator

## Helper

A special mobility helper is provided that is mainly aimed at supporting the installation of mobility to a Node container (when using containers at the helper API level). The MobilityHelper class encapsulates a MobilityModel factory object and a PositionAllocator used for initial node layout.

## ns-2 MobilityHelper

The ns-2 mobility format is a widely used mobility trace format. The documentation is available at: <http://www.isi.edu/nsnam/ns/doc/node172.html>

Valid trace files use the following ns2 statements:

```
$node set X_ x1
$node set Y_ y1
$node set Z_ z1
$ns at $time $node setdest x2 y2 speed
$ns at $time $node set X_ x1
$ns at $time $node set Y_ Y1
$ns at $time $node set Z_ Z1
```

Some examples of external tools that can export in this format include:

- BonnMotion <http://net.cs.uni-bonn.de/wg/cs/applications/bonnmotion/>
- SUMO [http://sourceforge.net/apps/mediawiki/sumo/index.php?title=Main\\_Page](http://sourceforge.net/apps/mediawiki/sumo/index.php?title=Main_Page)
- TraNS <http://trans.epfl.ch/>

A special Ns2MobilityHelper object can be used to parse these files and convert the statements into ns-3 mobility events.

### 19.1.2 Scope and Limitations

- only cartesian coordinates are presently supported

### 19.1.3 References

TBD

## 19.2 Usage

Most ns-3 program authors typically interact with the mobility system only at configuration time. However, various ns-3 objects interact with mobility objects repeatedly during runtime, such as a propagation model trying to determine the path loss between two mobile nodes.

### 19.2.1 Helper

A typical usage pattern can be found in the `third.cc` program in the tutorial.

First, the user instantiates a `MobilityHelper` object and sets some `Attributes` controlling the “position allocator” functionality.

```
MobilityHelper mobility;

mobility.SetPositionAllocator ("ns3::GridPositionAllocator",
    "MinX", DoubleValue (0.0),
    "MinY", DoubleValue (0.0),
    "DeltaX", DoubleValue (5.0),
    "DeltaY", DoubleValue (10.0),
    "GridWidth", UIntegerValue (3),
    "LayoutType", StringValue ("RowFirst"));
```

This code tells the mobility helper to use a two-dimensional grid to initially place the nodes. The first argument is an ns-3 `TypeId` specifying the type of mobility model; the remaining attribute/value pairs configure this position allocator.

Next, the user typically sets the `MobilityModel` subclass; e.g.:

```
mobility.SetMobilityModel ("ns3::RandomWalk2dMobilityModel",
    "Bounds", RectangleValue (Rectangle (-50, 50, -50, 50)));
```

Once the helper is configured, it is typically passed a container, such as:

```
mobility.Install (wifiStaNodes);
```

A `MobilityHelper` object may be reconfigured and reused for different `NodeContainers` during the configuration of an ns-3 scenario.

### 19.2.2 Use of Random Variables

A typical use case is to evaluate protocols on a mobile topology that involves some randomness in the motion or initial position allocation. To obtain random motion and positioning that is not affected by the configuration of the rest of the scenario, it is recommended to use the “AssignStreams” facility of the random number system.

Class `MobilityModel` and class `PositionAllocator` both have public API to assign streams to underlying random variables:

```
/**
 * Assign a fixed random variable stream number to the random variables
 * used by this model. Return the number of streams (possibly zero) that
 * have been assigned.
 *
 * \param stream first stream index to use
 * \return the number of stream indices assigned by this model
 */
int64_t AssignStreams (int64_t stream);
```

The class `MobilityHelper` also provides this API. The typical usage pattern when using the helper is:

```
int64_t streamIndex = /*some positive integer */
MobilityHelper mobility;
... (configure mobility)
mobility.Install (wifiStaNodes);
int64_t streamsUsed = mobility.AssignStreams (wifiStaNodes, streamIndex);
```

If `AssignStreams` is called before `Install`, it will not have any effect.

### 19.2.3 Advanced Usage

A number of external tools can be used to generate traces read by the `Ns2MobilityHelper`.

#### ns-2 scengen

TBD

#### BonnMotion

<http://net.cs.uni-bonn.de/wg/cs/applications/bonnmotion/>

#### SUMO

[http://sourceforge.net/apps/mediawiki/sumo/index.php?title=Main\\_Page](http://sourceforge.net/apps/mediawiki/sumo/index.php?title=Main_Page)

#### TraNS

<http://trans.epfl.ch/>

### 19.2.4 Examples

- `main-random-topology.cc`
- `main-random-walk.cc`
- `main-grid-topology.cc`
- `ns2-mobility-trace.cc`

## 19.3 Validation

TBD





# NETWORK MODULE

## 20.1 Packets

The design of the Packet framework of *ns* was heavily guided by a few important use-cases:

- avoid changing the core of the simulator to introduce new types of packet headers or trailers
- maximize the ease of integration with real-world code and systems
- make it easy to support fragmentation, defragmentation, and, concatenation which are important, especially in wireless systems.
- make memory management of this object efficient
- allow actual application data or dummy application bytes for emulated applications

Each network packet contains a byte buffer, a set of byte tags, a set of packet tags, and metadata.

The byte buffer stores the serialized content of the headers and trailers added to a packet. The serialized representation of these headers is expected to match that of real network packets bit for bit (although nothing forces you to do this) which means that the content of a packet buffer is expected to be that of a real packet.

Fragmentation and defragmentation are quite natural to implement within this context: since we have a buffer of real bytes, we can split it in multiple fragments and re-assemble these fragments. We expect that this choice will make it really easy to wrap our Packet data structure within Linux-style *skb* or BSD-style *mbuf* to integrate real-world kernel code in the simulator. We also expect that performing a real-time plug of the simulator to a real-world network will be easy.

One problem that this design choice raises is that it is difficult to pretty-print the packet headers without context. The packet metadata describes the type of the headers and trailers which were serialized in the byte buffer. The maintenance of metadata is optional and disabled by default. To enable it, you must call `Packet::EnableMetadata()` and this will allow you to get non-empty output from `Packet::Print` and `Packet::Print`.

Also, developers often want to store data in packet objects that is not found in the real packets (such as timestamps or flow-ids). The Packet class deals with this requirement by storing a set of tags (class `Tag`). We have found two classes of use cases for these tags, which leads to two different types of tags. So-called ‘byte’ tags are used to tag a subset of the bytes in the packet byte buffer while ‘packet’ tags are used to tag the packet itself. The main difference between these two kinds of tags is what happens when packets are copied, fragmented, and reassembled: ‘byte’ tags follow bytes while ‘packet’ tags follow packets. Another important difference between these two kinds of tags is that byte tags cannot be removed and are expected to be written once, and read many times, while packet tags are expected to be written once, read many times, and removed exactly once. An example of a ‘byte’ tag is a `FlowIdTag` which contains a flow id and is set by the application generating traffic. An example of a ‘packet’ tag is a cross-layer QoS class id set by an application and processed by a lower-level MAC layer.

Memory management of Packet objects is entirely automatic and extremely efficient: memory for the application-level payload can be modeled by a virtual buffer of zero-filled bytes for which memory is never allocated unless explicitly

requested by the user or unless the packet is fragmented or serialized out to a real network device. Furthermore, copying, adding, and, removing headers or trailers to a packet has been optimized to be virtually free through a technique known as Copy On Write.

Packets (messages) are fundamental objects in the simulator and their design is important from a performance and resource management perspective. There are various ways to design the simulation packet, and tradeoffs among the different approaches. In particular, there is a tension between ease-of-use, performance, and safe interface design.

### 20.1.1 Packet design overview

Unlike *ns-2*, in which Packet objects contain a buffer of C++ structures corresponding to protocol headers, each network packet in *ns-3* contains a byte Buffer, a list of byte Tags, and a PacketMetadata object:

- The byte buffer stores the serialized content of the chunks added to a packet. The serialized representation of these chunks is expected to match that of real network packets bit for bit (although nothing forces you to do this) which means that the content of a packet buffer is expected to be that of a real packet. Packets can also be created with an arbitrary zero-filled payload for which no real memory is allocated.
- Each list of tags stores an arbitrarily large set of arbitrary user-provided data structures in the packet. Each Tag is uniquely identified by its type; only one instance of each type of data structure is allowed in a list of tags. These tags typically contain per-packet cross-layer information or flow identifiers (i.e., things that you wouldn't find in the bits on the wire).

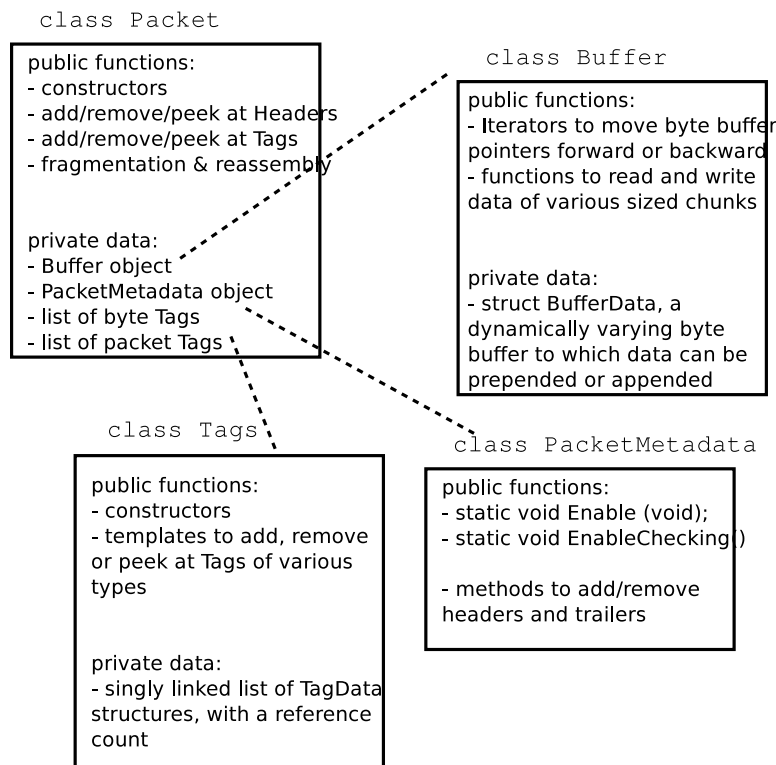

Figure 20.1: Implementation overview of Packet class.

Figure *Implementation overview of Packet class* is a high-level overview of the Packet implementation; more detail on the byte Buffer implementation is provided later in Figure *Implementation overview of a packet's byte Buffer*. In *ns-3*, the Packet byte buffer is analogous to a Linux skbuff or BSD mbuf; it is a serialized representation of the actual data in the packet. The tag lists are containers for extra items useful for simulation convenience; if a Packet is converted to

an emulated packet and put over an actual network, the tags are stripped off and the byte buffer is copied directly into a real packet.

Packets are reference counted objects. They are handled with smart pointer (Ptr) objects like many of the objects in the ns-3 system. One small difference you will see is that class Packet does not inherit from class Object or class RefCountBase, and implements the Ref() and Unref() methods directly. This was designed to avoid the overhead of a vtable in class Packet.

The Packet class is designed to be copied cheaply; the overall design is based on Copy on Write (COW). When there are multiple references to a packet object, and there is an operation on one of them, only so-called “dirty” operations will trigger a deep copy of the packet:

- ns3::Packet::AddHeader()
- ns3::Packet::AddTrailer()
- both versions of ns3::Packet::AddAtEnd()
- Packet::RemovePacketTag()

The fundamental classes for adding to and removing from the byte buffer are class Header and class Trailer. Headers are more common but the below discussion also largely applies to protocols using trailers. Every protocol header that needs to be inserted and removed from a Packet instance should derive from the abstract Header base class and implement the private pure virtual methods listed below:

- ns3::Header::SerializeTo()
- ns3::Header::DeserializeFrom()
- ns3::Header::GetSerializedSize()
- ns3::Header::PrintTo()

Basically, the first three functions are used to serialize and deserialize protocol control information to/from a Buffer. For example, one may define class TCPHeader : public Header. The TCPHeader object will typically consist of some private data (like a sequence number) and public interface access functions (such as checking the bounds of an input). But the underlying representation of the TCPHeader in a Packet Buffer is 20 serialized bytes (plus TCP options). The TCPHeader::SerializeTo() function would therefore be designed to write these 20 bytes properly into the packet, in network byte order. The last function is used to define how the Header object prints itself onto an output stream.

Similarly, user-defined Tags can be appended to the packet. Unlike Headers, Tags are not serialized into a contiguous buffer but are stored in lists. Tags can be flexibly defined to be any type, but there can only be one instance of any particular object type in the Tags buffer at any time.

## 20.1.2 Using the packet interface

This section describes how to create and use the ns3::Packet object.

### Creating a new packet

The following command will create a new packet with a new unique Id.:

```
Ptr<Packet> pkt = Create<Packet> ();
```

What is the Uid (unique Id)? It is an internal id that the system uses to identify packets. It can be fetched via the following method.:

```
uint32_t uid = pkt->GetUid ();
```

But please note the following. This uid is an internal uid and cannot be counted on to provide an accurate counter of how many “simulated packets” of a particular protocol are in the system. It is not trivial to make this uid into such a counter, because of questions such as what should the uid be when the packet is sent over broadcast media, or when fragmentation occurs. If a user wants to trace actual packet counts, he or she should look at e.g. the IP ID field or transport sequence numbers, or other packet or frame counters at other protocol layers.

We mentioned above that it is possible to create packets with zero-filled payloads that do not actually require a memory allocation (i.e., the packet may behave, when delays such as serialization or transmission delays are computed, to have a certain number of payload bytes, but the bytes will only be allocated on-demand when needed). The command to do this is, when the packet is created::

```
Ptr<Packet> pkt = Create<Packet> (N);
```

where N is a positive integer.

The packet now has a size of N bytes, which can be verified by the `GetSize()` method::

```
/**
 * \returns the size in bytes of the packet (including the zero-filled
 *       initial payload)
 */
uint32_t GetSize (void) const;
```

You can also initialize a packet with a character buffer. The input data is copied and the input buffer is untouched. The constructor applied is::

```
Packet (uint8_t const *buffer, uint32_t size);
```

Here is an example::

```
Ptr<Packet> pkt1 = Create<Packet> (reinterpret_cast<const uint8_t*> ("hello"), 5);
```

Packets are freed when there are no more references to them, as with all *ns-3* objects referenced by the `Ptr` class.

### **Adding and removing Buffer data**

After the initial packet creation (which may possibly create some fake initial bytes of payload), all subsequent buffer data is added by adding objects of class `Header` or class `Trailer`. Note that, even if you are in the application layer, handling packets, and want to write application data, you write it as an `ns3::Header` or `ns3::Trailer`. If you add a `Header`, it is prepended to the packet, and if you add a `Trailer`, it is added to the end of the packet. If you have no data in the packet, then it makes no difference whether you add a `Header` or `Trailer`. Since the APIs and classes for header and trailer are pretty much identical, we’ll just look at class `Header` here.

The first step is to create a new header class. All new `Header` classes must inherit from class `Header`, and implement the following methods:

- `Serialize ()`
- `Deserialize ()`
- `GetSerializedSize ()`
- `Print ()`

To see a simple example of how these are done, look at the `UdpHeader` class headers `src/internet/model/udp-header.cc`. There are many other examples within the source code.

Once you have a header (or you have a preexisting header), the following `Packet` API can be used to add or remove such headers.:

```

/**
 * Add header to this packet. This method invokes the
 * Header::GetSerializedSize and Header::Serialize
 * methods to reserve space in the buffer and request the
 * header to serialize itself in the packet buffer.
 *
 * \param header a reference to the header to add to this packet.
 */
void AddHeader (const Header & header);
/**
 * Deserialize and remove the header from the internal buffer.
 * This method invokes Header::Deserialize.
 *
 * \param header a reference to the header to remove from the internal buffer.
 * \returns the number of bytes removed from the packet.
 */
uint32_t RemoveHeader (Header &header);
/**
 * Deserialize but does not remove the header from the internal buffer.
 * This method invokes Header::Deserialize.
 *
 * \param header a reference to the header to read from the internal buffer.
 * \returns the number of bytes read from the packet.
 */
uint32_t PeekHeader (Header &header) const;

```

For instance, here are the typical operations to add and remove a UDP header:

```

// add header
Ptr<Packet> packet = Create<Packet> ();
UdpHeader udpHeader;
// Fill out udpHeader fields appropriately
packet->AddHeader (udpHeader);
...
// remove header
UdpHeader udpHeader;
packet->RemoveHeader (udpHeader);
// Read udpHeader fields as needed

```

## Adding and removing Tags

There is a single base class of Tag that all packet tags must derive from. They are used in two different tag lists in the packet; the lists have different semantics and different expected use cases.

As the names imply, ByteTags follow bytes and PacketTags follow packets. What this means is that when operations are done on packets, such as fragmentation, concatenation, and appending or removing headers, the byte tags keep track of which packet bytes they cover. For instance, if a user creates a TCP segment, and applies a ByteTag to the segment, each byte of the TCP segment will be tagged. However, if the next layer down inserts an IPv4 header, this ByteTag will not cover those bytes. The converse is true for the PacketTag; it covers a packet despite the operations on it.

PacketTags are limited in size to 20 bytes. This is a modifiable compile-time constant in `src/network/model/packet-tag-list.h`. ByteTags have no such restriction.

Each tag type must subclass `ns3::Tag`, and only one instance of each Tag type may be in each tag list. Here are a few differences in the behavior of packet tags and byte tags.

- **Fragmentation:** As mentioned above, when a packet is fragmented, each packet fragment (which is a new packet) will get a copy of all packet tags, and byte tags will follow the new packet boundaries (i.e. if the fragmented packets fragment across a buffer region covered by the byte tag, both packet fragments will still have the appropriate buffer regions byte tagged).
- **Concatenation:** When packets are combined, two different buffer regions will become one. For byte tags, the byte tags simply follow the respective buffer regions. For packet tags, only the tags on the first packet survive the merge.
- **Finding and Printing:** Both classes allow you to iterate over all of the tags and print them.
- **Removal:** Users can add and remove the same packet tag multiple times on a single packet (`AddPacketTag ()` and `RemovePacketTag ()`). The packet However, once a byte tag is added, it can only be removed by stripping all byte tags from the packet. Removing one of possibly multiple byte tags is not supported by the current API.

As of *ns-3.5* and later, Tags are not serialized and deserialized to a buffer when `Packet::Serialize ()` and `Packet::Deserialize ()` are called; this is an open bug.

If a user wants to take an existing packet object and reuse it as a new packet, he or she should remove all byte tags and packet tags before doing so. An example is the `UdpEchoServer` class, which takes the received packet and “turns it around” to send back to the echo client.

The Packet API for byte tags is given below.:

```
/**
 * \param tag the new tag to add to this packet
 *
 * Tag each byte included in this packet with the
 * new tag.
 *
 * Note that adding a tag is a const operation which is pretty
 * un-intuitive. The rationale is that the content and behavior of
 * a packet is not changed when a tag is added to a packet: any
 * code which was not aware of the new tag is going to work just
 * the same if the new tag is added. The real reason why adding a
 * tag was made a const operation is to allow a trace sink which gets
 * a packet to tag the packet, even if the packet is const (and most
 * trace sources should use const packets because it would be
 * totally evil to allow a trace sink to modify the content of a
 * packet).
 */
void AddByteTag (const Tag &tag) const;
/**
 * \returns an iterator over the set of byte tags included in this packet.
 */
ByteTagIterator GetByteTagIterator (void) const;
/**
 * \param tag the tag to search in this packet
 * \returns true if the requested tag type was found, false otherwise.
 *
 * If the requested tag type is found, it is copied in the user's
 * provided tag instance.
 */
bool FindFirstMatchingByteTag (Tag &tag) const;

/**
 * Remove all the tags stored in this packet.
 */
void RemoveAllByteTags (void);
```

```

/**
 * \param os output stream in which the data should be printed.
 *
 * Iterate over the tags present in this packet, and
 * invoke the Print method of each tag stored in the packet.
 */
void PrintByteTags (std::ostream &os) const;

```

The Packet API for packet tags is given below.:

```

/**
 * \param tag the tag to store in this packet
 *
 * Add a tag to this packet. This method calls the
 * Tag::GetSerializedSize and, then, Tag::Serialize.
 *
 * Note that this method is const, that is, it does not
 * modify the state of this packet, which is fairly
 * un-intuitive.
 */
void AddPacketTag (const Tag &tag) const;
/**
 * \param tag the tag to remove from this packet
 * \returns true if the requested tag is found, false
 *         otherwise.
 *
 * Remove a tag from this packet. This method calls
 * Tag::Deserialize if the tag is found.
 */
bool RemovePacketTag (Tag &tag);
/**
 * \param tag the tag to search in this packet
 * \returns true if the requested tag is found, false
 *         otherwise.
 *
 * Search a matching tag and call Tag::Deserialize if it is found.
 */
bool PeekPacketTag (Tag &tag) const;
/**
 * Remove all packet tags.
 */
void RemoveAllPacketTags (void);

/**
 * \param os the stream in which we want to print data.
 *
 * Print the list of 'packet' tags.
 *
 * \sa Packet::AddPacketTag, Packet::RemovePacketTag, Packet::PeekPacketTag,
 *     Packet::RemoveAllPacketTags
 */
void PrintPacketTags (std::ostream &os) const;

/**
 * \returns an object which can be used to iterate over the list of
 * packet tags.
 */
PacketTagIterator GetPacketTagIterator (void) const;

```

Here is a simple example illustrating the use of tags from the code in `src/internet/model/udp-socket-impl.cc`:

```
Ptr<Packet> p; // pointer to a pre-existing packet
SocketIpTtlTag tag;
tag.SetTtl (m_ipMulticastTtl); // Convey the TTL from UDP layer to IP layer
p->AddPacketTag (tag);
```

This tag is read at the IP layer, then stripped (`src/internet/model/ipv4-l3-protocol.cc`):

```
uint8_t ttl = m_defaultTtl;
SocketIpTtlTag tag;
bool found = packet->RemovePacketTag (tag);
if (found)
{
    ttl = tag.GetTtl ();
}
```

### Fragmentation and concatenation

Packets may be fragmented or merged together. For example, to fragment a packet `p` of 90 bytes into two packets, one containing the first 10 bytes and the other containing the remaining 80, one may call the following code::

```
Ptr<Packet> frag0 = p->CreateFragment (0, 10);
Ptr<Packet> frag1 = p->CreateFragment (10, 90);
```

As discussed above, the packet tags from `p` will follow to both packet fragments, and the byte tags will follow the byte ranges as needed.

Now, to put them back together::

```
frag0->AddAtEnd (frag1);
```

Now `frag0` should be equivalent to the original packet `p`. If, however, there were operations on the fragments before being reassembled (such as tag operations or header operations), the new packet will not be the same.

### Enabling metadata

We mentioned above that packets, being on-the-wire representations of byte buffers, present a problem to print out in a structured way unless the printing function has access to the context of the header. For instance, consider a `tcpdump`-like printer that wants to pretty-print the contents of a packet.

To enable this usage, packets may have metadata enabled (disabled by default for performance reasons). This class is used by the `Packet` class to record every operation performed on the packet's buffer, and provides an implementation of `Packet::Print ()` method that uses the metadata to analyze the content of the packet's buffer.

The metadata is also used to perform extensive sanity checks at runtime when performing operations on a `Packet`. For example, this metadata is used to verify that when you remove a header from a packet, this same header was actually present at the front of the packet. These errors will be detected and will abort the program.

To enable this operation, users will typically insert one or both of these statements at the beginning of their programs::

```
Packet::EnablePrinting ();
Packet::EnableChecking ();
```



### 20.1.3 Sample programs

See `src/network/examples/main-packet-header.cc` and `src/network/examples/main-packet-tag.cc`.

### 20.1.4 Implementation details

#### Private member variables

A Packet object's interface provides access to some private data::

```
Buffer m_buffer;
ByteTagList m_byteTagList;
PacketTagList m_packetTagList;
PacketMetadata m_metadata;
mutable uint32_t m_refCount;
static uint32_t m_globalUid;
```

Each Packet has a Buffer and two Tags lists, a PacketMetadata object, and a ref count. A static member variable keeps track of the UIDs allocated. The actual uid of the packet is stored in the PacketMetadata.

Note: that real network packets do not have a UID; the UID is therefore an instance of data that normally would be stored as a Tag in the packet. However, it was felt that a UID is a special case that is so often used in simulations that it would be more convenient to store it in a member variable.

#### Buffer implementation

Class Buffer represents a buffer of bytes. Its size is automatically adjusted to hold any data prepended or appended by the user. Its implementation is optimized to ensure that the number of buffer resizes is minimized, by creating new Buffers of the maximum size ever used. The correct maximum size is learned at runtime during use by recording the maximum size of each packet.

Authors of new Header or Trailer classes need to know the public API of the Buffer class. (add summary here)

The byte buffer is implemented as follows:

```
struct BufferData {
    uint32_t m_count;
    uint32_t m_size;
    uint32_t m_initialStart;
    uint32_t m_dirtyStart;
    uint32_t m_dirtySize;
    uint8_t m_data[1];
};
struct BufferData *m_data;
uint32_t m_zeroAreaSize;
uint32_t m_start;
uint32_t m_size;
```

- `BufferData::m_count`: reference count for BufferData structure
- `BufferData::m_size`: size of data buffer stored in BufferData structure
- `BufferData::m_initialStart`: offset from start of data buffer where data was first inserted
- `BufferData::m_dirtyStart`: offset from start of buffer where every Buffer which holds a reference to this BufferData instance have written data so far
- `BufferData::m_dirtySize`: size of area where data has been written so far

- `BufferData::m_data`: pointer to data buffer
- `Buffer::m_zeroAreaSize`: size of zero area which extends before `m_initialStart`
- `Buffer::m_start`: offset from start of buffer to area used by this buffer
- `Buffer::m_size`: size of area used by this Buffer in its BufferData structure

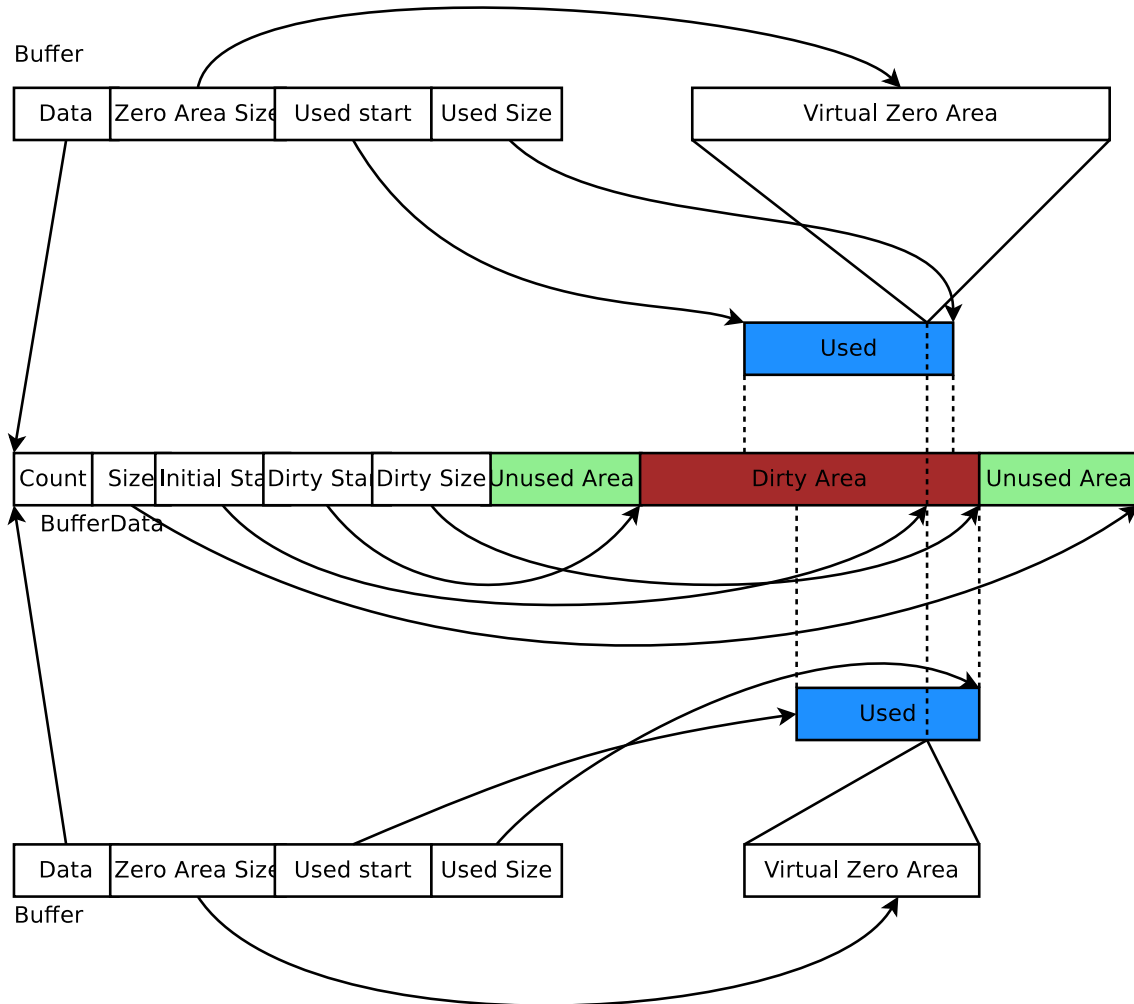

Figure 20.2: Implementation overview of a packet's byte Buffer.

This data structure is summarized in Figure *Implementation overview of a packet's byte Buffer*. Each Buffer holds a pointer to an instance of a BufferData. Most Buffers should be able to share the same underlying BufferData and thus simply increase the BufferData's reference count. If they have to change the content of a BufferData inside the Dirty Area, and if the reference count is not one, they first create a copy of the BufferData and then complete their state-changing operation.

### Tags implementation

(XXX revise me)

Tags are implemented by a single pointer which points to the start of a linked list of TagData data structures. Each TagData structure points to the next TagData in the list (its next pointer contains zero to indicate the end of the linked list). Each TagData contains an integer unique id which identifies the type of the tag stored in the TagData.:

```

struct TagData {
    struct TagData *m_next;
    uint32_t m_id;
    uint32_t m_count;
    uint8_t m_data[Tags::SIZE];
};
class Tags {
    struct TagData *m_next;
};

```

Adding a tag is a matter of inserting a new TagData at the head of the linked list. Looking at a tag requires you to find the relevant TagData in the linked list and copy its data into the user data structure. Removing a tag and updating the content of a tag requires a deep copy of the linked list before performing this operation. On the other hand, copying a Packet and its tags is a matter of copying the TagData head pointer and incrementing its reference count.

Tags are found by the unique mapping between the Tag type and its underlying id. This is why at most one instance of any Tag can be stored in a packet. The mapping between Tag type and underlying id is performed by a registration as follows::

```

/* A sample Tag implementation
 */
struct MyTag {
    uint16_t m_streamId;
};

```

## Memory management

*Describe dataless vs. data-full packets.*

## Copy-on-write semantics

The current implementation of the byte buffers and tag list is based on COW (Copy On Write). An introduction to COW can be found in Scott Meyer's "More Effective C++", items 17 and 29). This design feature and aspects of the public interface borrows from the packet design of the Georgia Tech Network Simulator. This implementation of COW uses a customized reference counting smart pointer class.

What COW means is that copying packets without modifying them is very cheap (in terms of CPU and memory usage) and modifying them can be also very cheap. What is key for proper COW implementations is being able to detect when a given modification of the state of a packet triggers a full copy of the data prior to the modification: COW systems need to detect when an operation is "dirty" and must therefore invoke a true copy.

Dirty operations:

- ns3::Packet::AddHeader
- ns3::Packet::AddTrailer
- both versions of ns3::Packet::AddAtEnd
- ns3::Packet::RemovePacketTag

Non-dirty operations:

- ns3::Packet::AddPacketTag
- ns3::Packet::PeekPacketTag
- ns3::Packet::RemoveAllPacketTags
- ns3::Packet::AddByteTag

- ns3::Packet::FindFirstMatchingByteTag
- ns3::Packet::RemoveAllByteTags
- ns3::Packet::RemoveHeader
- ns3::Packet::RemoveTrailer
- ns3::Packet::CreateFragment
- ns3::Packet::RemoveAtStart
- ns3::Packet::RemoveAtEnd
- ns3::Packet::CopyData

Dirty operations will always be slower than non-dirty operations, sometimes by several orders of magnitude. However, even the dirty operations have been optimized for common use-cases which means that most of the time, these operations will not trigger data copies and will thus be still very fast.

## 20.2 Node and NetDevices Overview

This chapter describes how *ns-3* nodes are put together, and provides a walk-through of how packets traverse an internet-based Node.

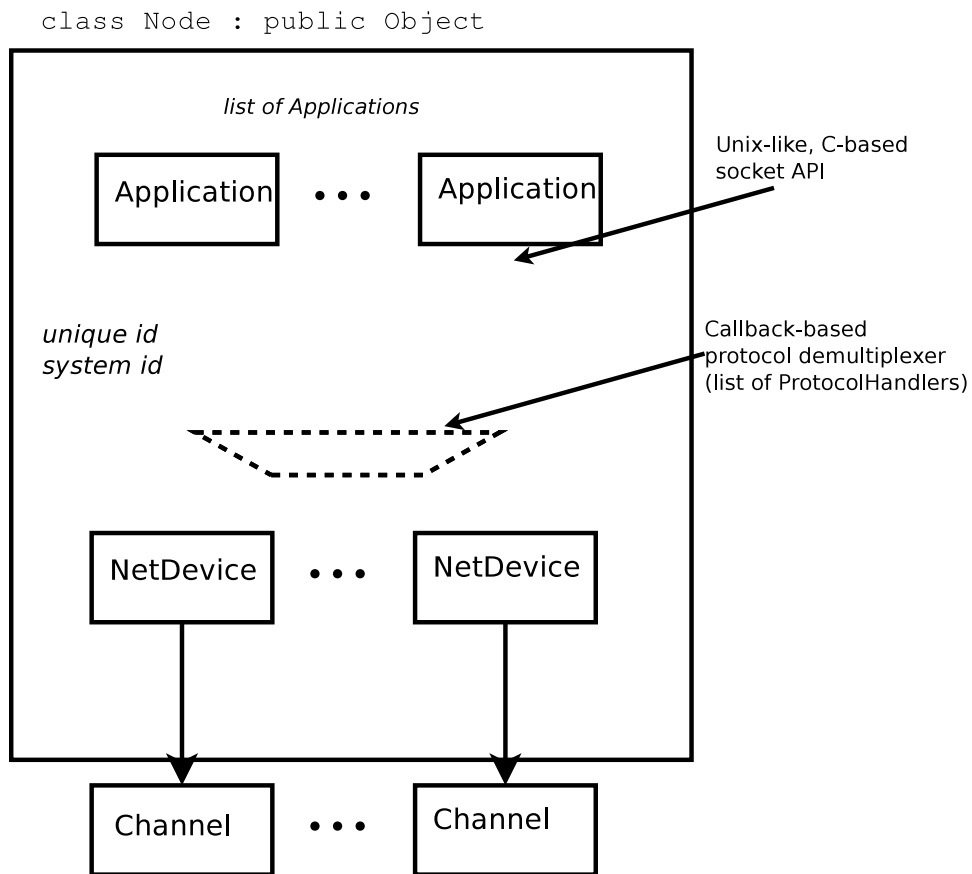

Figure 20.3: High-level node architecture

In *ns-3*, nodes are instances of `ns3::Node`. This class may be subclassed, but instead, the conceptual model is that we *aggregate* or insert objects to it rather than define subclasses.

One might think of a bare *ns-3* node as a shell of a computer, to which one may add `NetDevices` (cards) and other innards including the protocols and applications. *High-level node architecture* illustrates that `ns3::Node` objects contain a list of `ns3::Application` instances (initially, the list is empty), a list of `ns3::NetDevice` instances (initially, the list is empty), a list of `ns3::Node::ProtocolHandler` instances, a unique integer ID, and a system ID (for distributed simulation).

The design tries to avoid putting too many dependencies on the class `ns3::Node`, `ns3::Application`, or `ns3::NetDevice` for the following:

- IP version, or whether IP is at all even used in the `ns3::Node`.
- implementation details of the IP stack.

From a software perspective, the lower interface of applications corresponds to the C-based sockets API. The upper interface of `ns3::NetDevice` objects corresponds to the device independent sublayer of the Linux stack. Everything in between can be aggregated and plumbed together as needed.

Let's look more closely at the protocol demultiplexer. We want incoming frames at layer-2 to be delivered to the right layer-3 protocol such as IPv4. The function of this demultiplexer is to register callbacks for receiving packets. The callbacks are indexed based on the `EtherType` in the layer-2 frame.

Many different types of higher-layer protocols may be connected to the `NetDevice`, such as IPv4, IPv6, ARP, MPLS, IEEE 802.1x, and packet sockets. Therefore, the use of a callback-based demultiplexer avoids the need to use a common base class for all of these protocols, which is problematic because of the different types of objects (including packet sockets) expected to be registered there.

## 20.3 Sockets APIs

The `sockets API` is a long-standing API used by user-space applications to access network services in the kernel. A *socket* is an abstraction, like a Unix file handle, that allows applications to connect to other Internet hosts and exchange reliable byte streams and unreliable datagrams, among other services.

*ns-3* provides two types of sockets APIs, and it is important to understand the differences between them. The first is a *native ns-3* API, while the second uses the services of the native API to provide a *POSIX-like* API as part of an overall application process. Both APIs strive to be close to the typical sockets API that application writers on Unix systems are accustomed to, but the POSIX variant is much closer to a real system's sockets API.

### 20.3.1 ns-3 sockets API

The native sockets API for *ns-3* provides an interface to various types of transport protocols (TCP, UDP) as well as to packet sockets and, in the future, Netlink-like sockets. However, users are cautioned to understand that the semantics are *not* the exact same as one finds in a real system (for an API which is very much aligned to real systems, see the next section).

`ns3::Socket` is defined in `src/network/model/socket.h`. Readers will note that many public member functions are aligned with real sockets function calls, and all other things being equal, we have tried to align with a Posix sockets API. However, note that:

- *ns-3* applications handle a smart pointer to a `Socket` object, not a file descriptor;
- there is no notion of synchronous API or a *blocking* API; in fact, the model for interaction between application and socket is one of asynchronous I/O, which is not typically found in real systems (more on this below);
- the C-style socket address structures are not used;

- the API is not a complete sockets API, such as supporting all socket options or all function variants;
- many calls use `ns3::Packet` class to transfer data between application and socket. This may seem peculiar to pass *Packets* across a stream socket API, but think of these packets as just fancy byte buffers at this level (more on this also below).

### Basic operation and calls

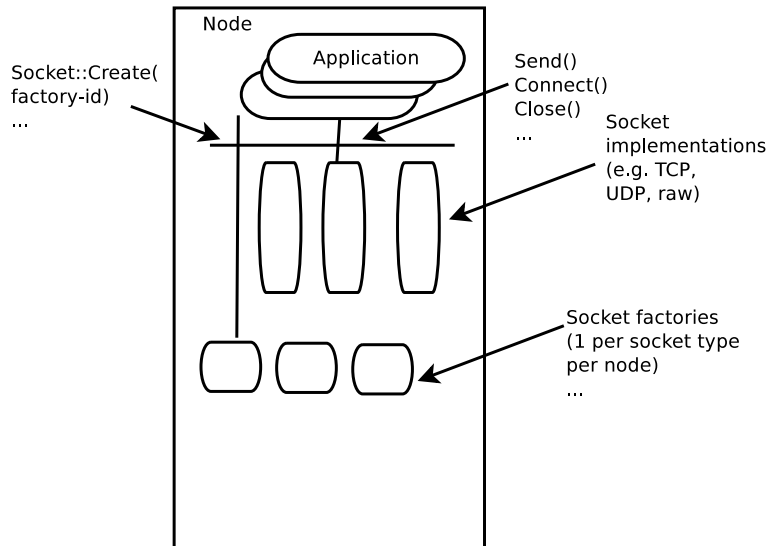

Figure 20.4: Implementation overview of native sockets API

### Creating sockets

An application that wants to use sockets must first create one. On real systems using a C-based API, this is accomplished by calling `socket()`

```
int socket(int domain, int type, int protocol);
```

which creates a socket in the system and returns an integer descriptor.

In ns-3, we have no equivalent of a system call at the lower layers, so we adopt the following model. There are certain *factory* objects that can create sockets. Each factory is capable of creating one type of socket, and if sockets of a particular type are able to be created on a given node, then a factory that can create such sockets must be aggregated to the Node:

```
static Ptr<Socket> CreateSocket (Ptr<Node> node, TypeId tid);
```

Examples of `TypeId`s to pass to this method are `ns3::TcpSocketFactory`, `ns3::PacketSocketFactory`, and `ns3::UdpSocketFactory`.

This method returns a smart pointer to a `Socket` object. Here is an example:

```
Ptr<Node> n0;
// Do some stuff to build up the Node's internet stack
Ptr<Socket> localSocket =
    Socket::CreateSocket (n0, TcpSocketFactory::GetTypeId ());
```

In some ns-3 code, sockets will not be explicitly created by user's main programs, if an ns-3 application does it. For instance, for `ns3::OnOffApplication`, the function `ns3::OnOffApplication::StartApplication()` performs the socket creation, and the application holds the socket pointer.

## Using sockets

Below is a typical sequence of socket calls for a TCP client in a real implementation:

- `sock = socket(PF_INET, SOCK_STREAM, IPPROTO_TCP);`
- `bind(sock, ...);`
- `connect(sock, ...);`
- `send(sock, ...);`
- `recv(sock, ...);`
- `close(sock);`

There are analogs to all of these calls in ns-3, but we will focus on two aspects here. First, most usage of sockets in real systems requires a way to manage I/O between the application and kernel. These models include *blocking sockets*, *signal-based I/O*, and *non-blocking sockets* with polling. In ns-3, we make use of the callback mechanisms to support a fourth mode, which is analogous to POSIX *asynchronous I/O*.

In this model, on the sending side, if the `send()` call were to fail because of insufficient buffers, the application suspends the sending of more data until a function registered at the `ns3::Socket::SetSendCallback()` callback is invoked. An application can also ask the socket how much space is available by calling `ns3::Socket::GetTxAvailable()`. A typical sequence of events for sending data (ignoring connection setup) might be::

```
* ``SetSendCallback (MakeCallback(&HandleSendCallback));``
* ``Send ();``
* ``Send ();``
* ...
* Send fails because buffer is full
* wait until :cpp:func:'HandleSendCallback' is called
* :cpp:func:'HandleSendCallback' is called by socket, since space now available
* ``Send (); // Start sending again``
```

Similarly, on the receive side, the socket user does not block on a call to `recv()`. Instead, the application sets a callback with `ns3::Socket::SetRecvCallback()` in which the socket will notify the application when (and how much) there is data to be read, and the application then calls `ns3::Socket::Recv()` to read the data until no more can be read.

### 20.3.2 Packet vs. buffer variants

There are two basic variants of `Send()` and `Recv()` supported:

```
virtual int Send (Ptr<Packet> p) = 0;
int Send (const uint8_t* buf, uint32_t size);

Ptr<Packet> Recv (void);
int Recv (uint8_t* buf, uint32_t size);
```

The non-Packet variants are provided for legacy API reasons. When calling the raw buffer variant of `ns3::Socket::Send()`, the buffer is immediately written into a Packet and the packet variant is invoked.

Users may find it semantically odd to pass a Packet to a stream socket such as TCP. However, do not let the name bother you; think of `ns3::Packet` to be a fancy byte buffer. There are a few reasons why the Packet variants are more likely to be preferred in ns-3:

- Users can use the Tags facility of packets to, for example, encode a flow ID or other helper data at the application layer.
- Users can exploit the copy-on-write implementation to avoid memory copies (on the receive side, the conversion back to a `uint8_t* buf` may sometimes incur an additional copy).
- Use of Packet is more aligned with the rest of the ns-3 API

### 20.3.3 Sending dummy data

Sometimes, users want the simulator to just pretend that there is an actual data payload in the packet (e.g. to calculate transmission delay) but do not want to actually produce or consume the data. This is straightforward to support in ns-3; have applications call `Create<Packet> (size);` instead of `Create<Packet> (buffer, size);`. Similarly, passing in a zero to the pointer argument in the raw buffer variants has the same effect. Note that, if some subsequent code tries to read the Packet data buffer, the fake buffer will be converted to a real (zeroed) buffer on the spot, and the efficiency will be lost there.

### 20.3.4 Socket options

*to be completed*

### 20.3.5 Socket errno

*to be completed*

### 20.3.6 Example programs

*to be completed*

### 20.3.7 POSIX-like sockets API

## 20.4 Simple NetDevice

*Placeholder chapter*

## 20.5 Queues

This section documents a few queue objects, typically associated with NetDevice models, that are maintained as part of the `network` module:

- DropTail
- Random Early Detection



## 20.5.1 Model Description

The source code for the new module lives in the directory `src/network/Utils`.

ns-3 provides a couple of classic queue models and the ability to trace certain queue operations such as enqueueing, dequeueing, and dropping. These may be added to certain `NetDevice` objects that take a `Ptr<Queue>` pointer.

Note that not all device models use these queue models. In particular, WiFi, WiMax, and LTE use specialized device queues. The queue models described here are more often used with simpler ns-3 device models such as `PointToPoint` and `Csma`.

### Design

An abstract base class, class `Queue`, is typically used and subclassed for specific scheduling and drop policies. Common operations include:

- `bool Enqueue (Ptr<Packet> p):` Enqueue a packet
- `Ptr<Packet> Dequeue (void):` Dequeue a packet
- `uint32_t GetNPackets (void):` Get the queue depth, in packets
- `uint32_t GetNBytes (void):` Get the queue depth, in bytes

as well as tracking some statistics on queue operations.

There are three trace sources that may be hooked:

- `Enqueue`
- `Dequeue`
- `Drop`

### DropTail

This is a basic first-in-first-out (FIFO) queue that performs a tail drop when the queue is full.

### Random Early Detection

Random Early Detection (RED) is a queue variant that aims to provide early signals to transport protocol congestion control (e.g. TCP) that congestion is imminent, so that they back off their rate gracefully rather than with a bunch of tail-drop losses (possibly incurring TCP timeout). The model in ns-3 is a port of Sally Floyd's ns-2 RED model.

### Scope and Limitations

The RED model just supports default RED. Adaptive RED is not supported.

### References

The RED queue aims to be close to the results cited in: S.Floyd, K.Fall <http://icir.org/floyd/papers/redsim.ps>

## 20.5.2 Usage

### Helpers

A typical usage pattern is to create a device helper and to configure the queue type and attributes from the helper, such as this example from `src/network/examples/red-tests.cc`:

```
PointToPointHelper p2p;

p2p.SetQueue ("ns3::DropTailQueue");
p2p.SetDeviceAttribute ("DataRate", StringValue ("10Mbps"));
p2p.SetChannelAttribute ("Delay", StringValue ("2ms"));
NetDeviceContainer devn0n2 = p2p.Install (n0n2);

p2p.SetQueue ("ns3::DropTailQueue");
p2p.SetDeviceAttribute ("DataRate", StringValue ("10Mbps"));
p2p.SetChannelAttribute ("Delay", StringValue ("3ms"));
NetDeviceContainer devn1n2 = p2p.Install (n1n2);

p2p.SetQueue ("ns3::RedQueue", // only backbone link has RED queue
             "LinkBandwidth", StringValue (redLinkDataRate),
             "LinkDelay", StringValue (redLinkDelay));
p2p.SetDeviceAttribute ("DataRate", StringValue (redLinkDataRate));
p2p.SetChannelAttribute ("Delay", StringValue (redLinkDelay));
NetDeviceContainer devn2n3 = p2p.Install (n2n3);
```

### Attributes

The RED queue contains a number of attributes that control the RED policies:

- Mode (bytes or packets)
- MeanPktSize
- IdlePktSize
- Wait (time)
- Gentle mode
- MinTh, MaxTh
- QueueLimit
- Queue weight
- LInterm
- LinkBandwidth
- LinkDelay

Consult the ns-3 documentation for explanation of these attributes.

### Output

The ns-3 ascii trace helpers used by many of the NetDevices will hook the Enqueue, Dequeue, and Drop traces of these queues and print out trace statements, such as the following from `examples/udp/udp-echo.cc`:

```
+ 2 /NodeList/0/DeviceList/1/$ns3::CsmaNetDevice/TxQueue/Enqueue ns3::EthernetHeader
( length/type=0x806, source=00:00:00:00:00:01, destination=ff:ff:ff:ff:ff:ff)
ns3::ArpHeader (request source mac: 00-06-00:00:00:00:01 source ipv4: 10.1.1.1
dest ipv4: 10.1.1.2) Payload (size=18) ns3::EthernetTrailer (fcs=0)
- 2 /NodeList/0/DeviceList/1/$ns3::CsmaNetDevice/TxQueue/Dequeue ns3::EthernetHeader
( length/type=0x806, source=00:00:00:00:00:01, destination=ff:ff:ff:ff:ff:ff)
ns3::ArpHeader (request source mac: 00-06-00:00:00:00:00:01 source ipv4: 10.1.1.1
dest ipv4: 10.1.1.2) Payload (size=18) ns3::EthernetTrailer (fcs=0)
```

which shows an enqueue “+” and dequeue “-” event at time 2 seconds.

Users are, of course, free to define and hook their own trace sinks to these trace sources.

## Examples

The drop-tail queue is used in several examples, such as `examples/udp/udp-echo.cc`. The RED queue example is found at `src/network/examples/red-tests.cc`.

### 20.5.3 Validation

The RED model has been validated and the report is currently stored at: <https://github.com/downloads/talau/ns-3-tcp-red/report-red-ns3.pdf>



# OPTIMIZED LINK STATE ROUTING (OLSR)

This model implements the base specification of the Optimized Link State Routing (OLSR) protocol, which is a dynamic mobile ad hoc unicast routing protocol. It has been developed at the University of Murcia (Spain) by Francisco J. Ros for NS-2, and was ported to NS-3 by Gustavo Carneiro at INESC Porto (Portugal).

## 21.1 Model Description

The source code for the OLSR model lives in the directory *src/olsr*.

### 21.1.1 Design

### 21.1.2 Scope and Limitations

The model is for IPv4 only.

- Mostly compliant with OLSR as documented in [rfc3626],
- The use of multiple interfaces was not supported by the NS-2 version, but is supported in NS-3;
- OLSR does not respond to the routing event notifications corresponding to dynamic interface up and down (`ns3::RoutingProtocol::NotifyInterfaceUp` and `ns3::RoutingProtocol::NotifyInterfaceDown`) or address insertion/removal (`ns3::RoutingProtocol::NotifyAddAddress` and `ns3::RoutingProtocol::NotifyRemoveAddress`).
- Unlike the NS-2 version, does not yet support MAC layer feedback as described in RFC 3626;

Host Network Association (HNA) is supported in this implementation of OLSR. Refer to `examples/olsr-hna.cc` to see how the API is used.

## 21.1.3 References

# 21.2 Usage

## 21.2.1 Examples

## 21.2.2 Helpers

A helper class for OLSR has been written. After an IPv4 topology has been created and unique IP addresses assigned to each node, the simulation script writer can call one of three overloaded functions with different scope to enable OLSR: `ns3::OlsrHelper::Install (NodeContainer container);` `ns3::OlsrHelper::Install (Ptr<Node> node);` or `ns3::OlsrHelper::InstallAll (void)`

## 21.2.3 Attributes

In addition, the behavior of OLSR can be modified by changing certain attributes. The method `ns3::OlsrHelper::Set ()` can be used to set OLSR attributes. These include `HelloInterval`, `TcInterval`, `MidInterval`, `Willingness`. Other parameters are defined as macros in `olsr-routing-protocol.cc`.

## 21.2.4 Tracing

## 21.2.5 Logging

## 21.2.6 Caveats

# 21.3 Validation

## 21.3.1 Unit tests

## 21.3.2 Larger-scale performance tests

# OPENFLOW SWITCH SUPPORT

ns-3 simulations can use OpenFlow switches (McKeown et al. <sup>1</sup>), widely used in research. OpenFlow switches are configurable via the OpenFlow API, and also have an MPLS extension for quality-of-service and service-level-agreement support. By extending these capabilities to ns-3 for a simulated OpenFlow switch that is both configurable and can use the MPLS extension, ns-3 simulations can accurately simulate many different switches.

The OpenFlow software implementation distribution is hereby referred to as the OFSID. This is a demonstration of running OpenFlow in software that the OpenFlow research group has made available. There is also an OFSID that Ericsson researchers created to add MPLS capabilities; this is the OFSID currently used with ns-3. The design will allow the users to, with minimal effort, switch in a different OFSID that may include more efficient code than a previous OFSID.

## 22.1 Model Description

The model relies on building an external OpenFlow switch library (OFSID), and then building some ns-3 wrappers that call out to the library. The source code for the ns-3 wrappers lives in the directory `src/openflow/model`.

### 22.1.1 Design

The OpenFlow module presents a `OpenFlowSwitchNetDevice` and a `OpenFlowSwitchHelper` for installing it on nodes. Like the `Bridge` module, it takes a collection of `NetDevices` to set up as ports, and it acts as the intermediary between them, receiving a packet on one port and forwarding it on another, or all but the received port when flooding. Like an OpenFlow switch, it maintains a configurable flow table that can match packets by their headers and do different actions with the packet based on how it matches. The module's understanding of OpenFlow configuration messages are kept the same format as a real OpenFlow-compatible switch, so users testing Controllers via ns-3 won't have to rewrite their Controller to work on real OpenFlow-compatible switches.

The ns-3 OpenFlow switch device models an OpenFlow-enabled switch. It is designed to express basic use of the OpenFlow protocol, with the maintaining of a virtual Flow Table and TCAM to provide OpenFlow-like results.

The functionality comes down to the Controllers, which send messages to the switch that configure its flows, producing different effects. Controllers can be added by the user, under the `ofi` namespace extending `ofi::Controller`. To demonstrate this, a `DropController`, which creates flows for ignoring every single packet, and `LearningController`, which effectively makes the switch a more complicated `BridgeNetDevice`. A user versed in a standard OFSID, and/or OF protocol, can write virtual controllers to create switches of all kinds of types.

---

<sup>1</sup> McKeown, N.; Anderson, T.; Balakrishnan, H.; Parulkar, G.; Peterson, L.; Rexford, J.; Shenker, S.; Turner, J.; OpenFlow: enabling innovation in campus networks, ACM SIGCOMM Computer Communication Review, Vol. 38, Issue 2, April 2008.

## OpenFlow switch Model

The OpenFlow switch device behaves somewhat according to the diagram setup as a classical OFSID switch, with a few modifications made for a proper simulation environment.

Normal OF-enabled Switch::

```
| Secure Channel | <--OF Protocol--> | Controller is external |  
| Hardware or Software Flow Table |
```

ns-3 OF-enabled Switch (module)::

```
| m_controller->ReceiveFromSwitch() | <--OF Protocol--> | Controller is internal |  
| Software Flow Table, virtual TCAM |
```

In essence, there are two differences:

1) No SSL, Embedded Controller: Instead of a secure channel and connecting to an outside location for the Controller program/machine, we currently only allow a Controller extended from `ofi::Controller`, an extension of an `ns3::Object`. This means ns-3 programmers cannot model the SSL part of the interface or possibility of network failure. The connection to the `OpenFlowSwitch` is local and there aren't any reasons for the channel/connection to break down. <<This difference may be an option in the future. Using `EmuNetDevices`, it should be possible to engage an external Controller program/machine, and thus work with controllers designed outside of the ns-3 environment, that simply use the proper OF protocol when communicating messages to the switch through a tap device.>>

2) Virtual Flow Table, TCAM: Typical OF-enabled switches are implemented on a hardware TCAM. The OFSID we turn into a library includes a modelled software TCAM, that produces the same results as a hardware TCAM. We include an attribute `FlowTableLookupDelay`, which allows a simple delay of using the TCAM to be modelled. We don't endeavor to make this delay more complicated, based on the tasks we are running on the TCAM, that is a possible future improvement.

The `OpenFlowSwitch` network device is aimed to model an OpenFlow switch, with a TCAM and a connection to a controller program. With some tweaking, it can model every switch type, per OpenFlow's extensibility. It outsources the complexity of the switch ports to `NetDevices` of the user's choosing. It should be noted that these `NetDevices` must behave like practical switch ports, i.e. a Mac Address is assigned, and nothing more. It also must support a `SendFrom` function so that the `OpenFlowSwitch` can forward across that port.

### 22.1.2 Scope and Limitations

All MPLS capabilities are implemented on the OFSID side in the `OpenFlowSwitchNetDevice`, but ns-3-mpls hasn't been integrated, so ns-3 has no way to pass in proper MPLS packets to the `OpenFlowSwitch`. If it did, one would only need to make `BufferFromPacket` pick up the `MplsLabelStack` or whatever the MPLS header is called on the `Packet`, and build the MPLS header into the `ofpbuf`.

### 22.1.3 Future Work

### 22.1.4 References

## 22.2 Usage

The OFSID requires `libxml2` (for MPLS FIB xml file parsing), `libdl` (for address fault checking), and `boost` (for assert) libraries to be installed.



## 22.2.1 Building OFSID

In order to use the OpenFlowSwitch module, you must create and link the OFSID (OpenFlow Software Implementation Distribution) to ns-3. To do this:

#1 Obtain the OFSID code. An ns-3 specific OFSID branch is provided to ensure operation with ns-3. Use mercurial to download this branch and waf to build the library::

```
$ hg clone http://code.nsnam.org/jpelkey3/openflow
$ cd openflow
```

From the “openflow” directory, run::

```
$ ./waf configure
$ ./waf build
```

#2 Your OFSID is now built into a libopenflow.a library! To link to an ns-3 build with this OpenFlow switch module, run from the ns-3-dev (or whatever you have named your distribution)::

```
$ ./waf configure --enable-examples --enable-tests --with-openflow=path/to/openflow
```

#3 Under ---- Summary of optional NS-3 features: you should see::

```
"NS-3 OpenFlow Integration      : enabled"
```

indicating the library has been linked to ns-3. Run::

```
$ ./waf build
```

to build ns-3 and activate the OpenFlowSwitch module in ns-3.

## 22.2.2 Examples

For an example demonstrating its use in a simple learning controller/switch, run::

```
$ ./waf --run openflow-switch
```

To see it in detailed logging, run::

```
$ ./waf --run "openflow-switch -v"
```

## 22.2.3 Helpers

## 22.2.4 Attributes

The SwitchNetDevice provides following Attributes:

- **FlowTableLookUpDelay:** This time gets run off the clock when making a lookup in our Flow Table.
- **Flags: OpenFlow specific configuration flags. They are defined in the ofp\_config\_flags enum. Choices include:**
  - OFPC\_SEND\_FLOW\_EXP (Switch notifies controller when a flow has expired),
  - OFPC\_FRAG\_NORMAL (Match fragment against Flow table),
  - OFPC\_FRAG\_DROP (Drop fragments),
  - OFPC\_FRAG\_REASM (Reassemble only if OFPC\_IP\_REASM set, which is currently impossible, because switch implementation does not support IP reassembly)
  - OFPC\_FRAG\_MASK (Mask Fragments)
- **FlowTableMissSendLength: When the packet doesn't match in our Flow Table, and we forward to the controller,** this sets # of bytes forwarded (packet is not forwarded in its entirety, unless specified).

---

**Note:** TODO

---

### 22.2.5 Tracing

---

**Note:** TODO

---

### 22.2.6 Logging

---

**Note:** TODO

---

### 22.2.7 Caveats

---

**Note:** TODO

---

## 22.3 Validation

This model has one test suite which can be run as follows::

```
$ ./test.py --suite=openflow
```

# POINTTOPOINT NETDEVICE

This is the introduction to PointToPoint NetDevice chapter, to complement the PointToPoint model doxygen.

## 23.1 Overview of the PointToPoint model

The *ns-3* point-to-point model is of a very simple point to point data link connecting exactly two PointToPointNetDevice devices over an PointToPointChannel. This can be viewed as equivalent to a full duplex RS-232 or RS-422 link with null modem and no handshaking.

Data is encapsulated in the Point-to-Point Protocol (PPP – RFC 1661), however the Link Control Protocol (LCP) and associated state machine is not implemented. The PPP link is assumed to be established and authenticated at all times.

Data is not framed, therefore Address and Control fields will not be found. Since the data is not framed, there is no need to provide Flag Sequence and Control Escape octets, nor is a Frame Check Sequence appended. All that is required to implement non-framed PPP is to prepend the PPP protocol number for IP Version 4 which is the sixteen-bit number 0x21 (see <http://www.iana.org/assignments/ppp-numbers>).

The PointToPointNetDevice provides following Attributes:

- Address: The ns3::Mac48Address of the device (if desired);
- DataRate: The data rate (ns3::DataRate) of the device;
- TxQueue: The transmit queue (ns3::Queue) used by the device;
- InterframeGap: The optional ns3::Time to wait between “frames”;
- Rx: A trace source for received packets;
- Drop: A trace source for dropped packets.

The PointToPointNetDevice models a transmitter section that puts bits on a corresponding channel “wire.” The DataRate attribute specifies the number of bits per second that the device will simulate sending over the channel. In reality no bits are sent, but an event is scheduled for an elapsed time consistent with the number of bits in each packet and the specified DataRate. The implication here is that the receiving device models a receiver section that can receive any any data rate. Therefore there is no need, nor way to set a receive data rate in this model. By setting the DataRate on the transmitter of both devices connected to a given PointToPointChannel one can model a symmetric channel; or by setting different DataRates one can model an asymmetric channel (e.g., ADSL).

The PointToPointNetDevice supports the assignment of a “receive error model.” This is an ErrorModel object that is used to simulate data corruption on the link.

## 23.2 Point-to-Point Channel Model

The point to point net devices are connected via an `PointToPointChannel`. This channel models two wires transmitting bits at the data rate specified by the source net device. There is no overhead beyond the eight bits per byte of the packet sent. That is, we do not model Flag Sequences, Frame Check Sequences nor do we “escape” any data.

The `PointToPointChannel` provides following Attributes:

- Delay: An `ns3::Time` specifying the speed of light transmission delay for the channel.

## 23.3 Using the `PointToPointNetDevice`

The `PointToPoint` net devices and channels are typically created and configured using the associated `PointToPointHelper` object. The various ns3 device helpers generally work in a similar way, and their use is seen in many of our example programs and is also covered in the *ns-3* tutorial.

The conceptual model of interest is that of a bare computer “husk” into which you plug net devices. The bare computers are created using a `NodeContainer` helper. You just ask this helper to create as many computers (we call them `Nodes`) as you need on your network::

```
NodeContainer nodes;  
nodes.Create (2);
```

Once you have your nodes, you need to instantiate a `PointToPointHelper` and set any attributes you may want to change. Note that since this is a point-to-point (as compared to a point-to-multipoint) there may only be two nodes with associated net devices connected by a `PointToPointChannel`::

```
PointToPointHelper pointToPoint;  
pointToPoint.SetDeviceAttribute ("DataRate", StringValue ("5Mbps"));  
pointToPoint.SetChannelAttribute ("Delay", StringValue ("2ms"));
```

Once the attributes are set, all that remains is to create the devices and install them on the required nodes, and to connect the devices together using a `PointToPoint` channel. When we create the net devices, we add them to a container to allow you to use them in the future. This all takes just one line of code.:

```
NetDeviceContainer devices = pointToPoint.Install (nodes);
```

## 23.4 PointToPoint Tracing

Like all *ns-3* devices, the Point-to-Point Model provides a number of trace sources. These trace sources can be hooked using your own custom trace code, or you can use our helper functions to arrange for tracing to be enabled on devices you specify.

### 23.4.1 Upper-Level (MAC) Hooks

From the point of view of tracing in the net device, there are several interesting points to insert trace hooks. A convention inherited from other simulators is that packets destined for transmission onto attached networks pass through a single “transmit queue” in the net device. We provide trace hooks at this point in packet flow, which corresponds (abstractly) only to a transition from the network to data link layer, and call them collectively the device MAC hooks.

When a packet is sent to the Point-to-Point net device for transmission it always passes through the transmit queue. The transmit queue in the `PointToPointNetDevice` inherits from `Queue`, and therefore inherits three trace sources::

- \* An Enqueue operation source (see `ns3::Queue::m_traceEnqueue`);
- \* A Dequeue operation source (see `ns3::Queue::m_traceDequeue`);
- \* A Drop operation source (see `ns3::Queue::m_traceDrop`).

The upper-level (MAC) trace hooks for the `PointToPointNetDevice` are, in fact, exactly these three trace sources on the single transmit queue of the device.

The `m_traceEnqueue` event is triggered when a packet is placed on the transmit queue. This happens at the time that `ns3::PointToPointNetDevice::Send` or `ns3::PointToPointNetDevice::SendFrom` is called by a higher layer to queue a packet for transmission. An Enqueue trace event firing should be interpreted as only indicating that a higher level protocol has sent a packet to the device.

The `m_traceDequeue` event is triggered when a packet is removed from the transmit queue. Dequeues from the transmit queue can happen in two situations: 1) If the underlying channel is idle when `PointToPointNetDevice::Send` is called, a packet is dequeued from the transmit queue and immediately transmitted; 2) a packet may be dequeued and immediately transmitted in an internal `TransmitCompleteEvent` that functions much like a transmit complete interrupt service routine. An Dequeue trace event firing may be viewed as indicating that the `PointToPointNetDevice` has begun transmitting a packet.

### 23.4.2 Lower-Level (PHY) Hooks

Similar to the upper level trace hooks, there are trace hooks available at the lower levels of the net device. We call these the PHY hooks. These events fire from the device methods that talk directly to the `PointToPointChannel`.

The trace source `m_dropTrace` is called to indicate a packet that is dropped by the device. This happens when a packet is discarded as corrupt due to a receive error model indication (see `ns3::ErrorModel` and the associated attribute “`ReceiveErrorModel`”).

The other low-level trace source fires on reception of a packet (see `ns3::PointToPointNetDevice::m_rxTrace`) from the `PointToPointChannel`.



# PROPAGATION

The *ns-3* propagation module defines two generic interfaces, namely `PropagationLossModel` and `PropagationDelayModel`, for the modeling of respectively propagation loss and propagation delay.

## 24.1 PropagationLossModel

Each of the available propagation loss models of *ns-3* is explained in one of the following subsections.

### 24.1.1 FriisPropagationLossModel

### 24.1.2 TwoRayGroundPropagationLossModel

### 24.1.3 LogDistancePropagationLossModel

### 24.1.4 ThreeLogDistancePropagationLossModel

### 24.1.5 JakesPropagationLossModel

### 24.1.6 PropagationLossModel

### 24.1.7 RandomPropagationLossModel

### 24.1.8 NakagamiPropagationLossModel

### 24.1.9 FixedRssLossModel

### 24.1.10 MatrixPropagationLossModel

### 24.1.11 RangePropagationLossModel

### 24.1.12 OkumuraHataPropagationLossModel

This model is used to model open area pathloss for long distance (i.e.,  $> 1$  Km). In order to include all the possible frequencies usable by LTE we need to consider several variants of the well known Okumura Hata model. In fact, the original Okumura Hata model [hata] is designed for frequencies ranging from 150 MHz to 1500 MHz, the COST231 [cost231] extends it for the frequency range from 1500 MHz to 2000 MHz. Another important aspect is the scenarios

considered by the models, in fact the all models are originally designed for urban scenario and then only the standard one and the COST231 are extended to suburban, while only the standard one has been extended to open areas. Therefore, the model cannot cover all scenarios at all frequencies. In the following we detail the models adopted.

The pathloss expression of the COST231 OH is:

$$L = 46.3 + 33.9 \log f - 13.82 \log h_b + (44.9 - 6.55 \log h_b) \log d - F(h_M) + C$$

where

$$F(h_M) = \begin{cases} (1.1 \log(f)) - 0.7 \times h_M - (1.56 \times \log(f) - 0.8) & \text{for medium and small size cities} \\ 3.2 \times (\log(11.75 \times h_M))^2 & \text{for large cities} \end{cases}$$

$$C = \begin{cases} 0dB & \text{for medium-size cities and suburban areas} \\ 3dB & \text{for large cities} \end{cases}$$

and

$f$  : frequency [MHz]

$h_b$  : eNB height above the ground [m]

$h_M$  : UE height above the ground [m]

$d$  : distance [km]

$\log$  : is a logarithm in base 10 (this for the whole document)

This model is only for urban scenarios.

The pathloss expression of the standard OH in urban area is:

$$L = 69.55 + 26.16 \log f - 13.82 \log h_b + (44.9 - 6.55 \log h_b) \log d - C_H$$

where for small or medium sized city

$$C_H = 0.8 + (1.1 \log f - 0.7)h_M - 1.56 \log f$$

and for large cities

$$C_H = \begin{cases} 8.29(\log(1.54h_M))^2 - 1.1 & \text{if } 150 \leq f \leq 200 \\ 3.2(\log(11.75h_M))^2 - 4.97 & \text{if } 200 < f \leq 1500 \end{cases}$$

There extension for the standard OH in suburban is

$$L_{SU} = L_U - 2 \left( \log \frac{f}{28} \right)^2 - 5.4$$

where

$L_U$  : pathloss in urban areas

The extension for the standard OH in open area is

$$L_O = L_U - 4.70(\log f)^2 + 18.33 \log f - 40.94$$

The literature lacks of extensions of the COST231 to open area (for suburban it seems that we can just impose  $C = 0$ ); therefore we consider it a special case fo the suburban one.



### 24.1.13 ItuR1411LosPropagationLossModel

This model is designed for Line-of-Sight (LoS) short range outdoor communication in the frequency range 300 MHz to 100 GHz. This model provides an upper and lower bound respectively according to the following formulas

$$L_{\text{LoS},l} = L_{\text{bp}} + \begin{cases} 20 \log \frac{d}{R_{\text{bp}}} & \text{for } d \leq R_{\text{bp}} \\ 40 \log \frac{d}{R_{\text{bp}}} & \text{for } d > R_{\text{bp}} \end{cases}$$

$$L_{\text{LoS},u} = L_{\text{bp}} + 20 + \begin{cases} 25 \log \frac{d}{R_{\text{bp}}} & \text{for } d \leq R_{\text{bp}} \\ 40 \log \frac{d}{R_{\text{bp}}} & \text{for } d > R_{\text{bp}} \end{cases}$$

where the breakpoint distance is given by

$$R_{\text{bp}} \approx \frac{4h_b h_m}{\lambda}$$

and the above parameters are

$\lambda$  : wavelength [m]

$h_b$  : eNB height above the ground [m]

$h_m$  : UE height above the ground [m]

$d$  : distance [m]

and  $L_{\text{bp}}$  is the value for the basic transmission loss at the break point, defined as:

$$L_{\text{bp}} = \left| 20 \log \left( \frac{\lambda^2}{8\pi h_b h_m} \right) \right|$$

The value used by the simulator is the average one for modeling the median pathloss.

### 24.1.14 ItuR1411NlosOverRooftopPropagationLossModel

This model is designed for Non-Line-of-Sight (LoS) short range outdoor communication over rooftops in the frequency range 300 MHz to 100 GHz. This model includes several scenario-dependent parameters, such as average street width, orientation, etc. It is advised to set the values of these parameters manually (using the ns-3 attribute system) according to the desired scenario.

In detail, the model is based on [walfisch] and [ikegami], where the loss is expressed as the sum of free-space loss ( $L_{bf}$ ), the diffraction loss from rooftop to street ( $L_{rts}$ ) and the reduction due to multiple screen diffraction past rows of building ( $L_{msd}$ ). The formula is:

$$L_{\text{NLOS}1} = \begin{cases} L_{bf} + L_{rts} + L_{msd} & \text{for } L_{rts} + L_{msd} > 0 \\ L_{bf} & \text{for } L_{rts} + L_{msd} \leq 0 \end{cases}$$

The free-space loss is given by:

$$L_{bf} = 32.4 + 20 \log(d/1000) + 20 \log(f)$$

where:

$f$  : frequency [MHz]

$d$  : distance (where  $d > 1$ ) [m]

The term  $L_{rts}$  takes into account the width of the street and its orientation, according to the formulas

$$L_{rts} = -8.2 - 10 \log(w) + 10 \log(f) + 20 \log(\Delta h_m) + L_{ori}$$

$$L_{ori} = \begin{cases} -10 + 0.354\varphi & \text{for } 0^\circ \leq \varphi < 35^\circ \\ 2.5 + 0.075(\varphi - 35) & \text{for } 35^\circ \leq \varphi < 55^\circ \\ 4.0 - 0.114(\varphi - 55) & \text{for } 55^\circ \leq \varphi \leq 90^\circ \end{cases}$$

$$\Delta h_m = h_r - h_m$$

where:

$h_r$  : is the height of the rooftop [m]

$h_m$  : is the height of the mobile [m]

$\varphi$  : is the street orientation with respect to the direct path (degrees)

The multiple screen diffraction loss depends on the BS antenna height relative to the building height and on the incidence angle. The former is selected as the higher antenna in the communication link. Regarding the latter, the “settled field distance” is used for select the proper model; its value is given by

$$d_s = \frac{\lambda d^2}{\Delta h_b^2}$$

with

$$\Delta h_b = h_b - h_m$$

Therefore, in case of  $l > d_s$  (where  $l$  is the distance over which the building extend), it can be evaluated according to

$$L_{msd} = L_{bsh} + k_a + k_d \log(d/1000) + k_f \log(f) - 9 \log(b)$$

$$L_{bsh} = \begin{cases} -18 \log(1 + \Delta h_b) & \text{for } h_b > h_r \\ 0 & \text{for } h_b \leq h_r \end{cases}$$

$$k_a = \begin{cases} 71.4 & \text{for } h_b > h_r \text{ and } f > 2000 \text{ MHz} \\ 54 & \text{for } h_b > h_r \text{ and } f \leq 2000 \text{ MHz} \\ 54 - 0.8\Delta h_b & \text{for } h_b \leq h_r \text{ and } d \geq 500 \text{ m} \\ 54 - 1.6\Delta h_b & \text{for } h_b \leq h_r \text{ and } d < 500 \text{ m} \end{cases}$$

$$k_d = \begin{cases} 18 & \text{for } h_b > h_r \\ 18 - 15 \frac{\Delta h_b}{h_r} & \text{for } h_b \leq h_r \end{cases}$$

$$k_f = \begin{cases} -8 & \text{for } f > 2000 \text{ MHz} \\ -4 + 0.7(f/925 - 1) & \text{for medium city and suburban centres and } f \leq 2000 \text{ MHz} \\ -4 + 1.5(f/925 - 1) & \text{for metropolitan centres and } f \leq 2000 \text{ MHz} \end{cases}$$

Alternatively, in case of  $l < d_s$ , the formula is:

$$L_{msd} = -10 \log(Q_M^2)$$

where

$$Q_M = \begin{cases} 2.35 \left( \frac{\Delta h_b}{d} \sqrt{\frac{b}{\lambda}} \right)^{0.9} & \text{for } h_b > h_r \\ \frac{b}{d} & \text{for } h_b \approx h_r \\ \frac{b}{2\pi d} \sqrt{\frac{\lambda}{\rho}} \left( \frac{1}{\theta} - \frac{1}{2\pi + \theta} \right) & \text{for } h_b < h_r \end{cases}$$

where:

$$\theta = \arctan\left(\frac{\Delta h_b}{b}\right)$$

$$\rho = \sqrt{\Delta h_b^2 + b^2}$$

### 24.1.15 Kun2600MhzPropagationLossModel

This is the empirical model for the pathloss at 2600 MHz for urban areas which is described in [kun2600mhz]. The model is as follows. Let  $d$  be the distance between the transmitter and the receiver in meters; the pathloss  $L$  in dB is calculated as:

$$L = 36 + 26 \log d$$

## 24.2 PropagationDelayModel

The following propagation delay models are implemented:

### 24.2.1 PropagationDelayModel

### 24.2.2 RandomPropagationDelayModel

### 24.2.3 ConstantSpeedPropagationDelayModel



# STATISTICAL FRAMEWORK

This chapter outlines work on simulation data collection and the statistical framework for ns-3.

The source code for the statistical framework lives in the directory `src/stats`.

## 25.1 Goals

Primary objectives for this effort are the following:

- Provide functionality to record, calculate, and present data and statistics for analysis of network simulations.
- Boost simulation performance by reducing the need to generate extensive trace logs in order to collect data.
- Enable simulation control via online statistics, e.g. terminating simulations or repeating trials.

Derived sub-goals and other target features include the following:

- Integration with the existing ns-3 tracing system as the basic instrumentation framework of the internal simulation engine, e.g. network stacks, net devices, and channels.
- Enabling users to utilize the statistics framework without requiring use of the tracing system.
- Helping users create, aggregate, and analyze data over multiple trials.
- Support for user created instrumentation, e.g. of application specific events and measures.
- Low memory and CPU overhead when the package is not in use.
- Leveraging existing analysis and output tools as much as possible. The framework may provide some basic statistics, but the focus is on collecting data and making it accessible for manipulation in established tools.
- Eventual support for distributing independent replications is important but not included in the first round of features.

## 25.2 Overview

The statistics framework includes the following features:

- The core framework and two basic data collectors: A counter, and a min/max/avg/total observer.
- Extensions of those to easily work with times and packets.
- Plaintext output formatted for omnetpp.
- Database output using sqlite3, a standalone, lightweight, high performance SQL engine.

- Mandatory and open ended metadata for describing and working with runs.
- An example based on the notional experiment of examining the properties of NS-3's default ad hoc WiFi performance. It incorporates the following:
  - Constructs of a two node ad hoc WiFi network, with the nodes a parameterized distance apart.
  - UDP traffic source and sink applications with slightly different behavior and measurement hooks than the stock classes.
  - Data collection from the NS-3 core via existing trace signals, in particular data on frames transmitted and received by the WiFi MAC objects.
  - Instrumentation of custom applications by connecting new trace signals to the stat framework, as well as via direct updates. Information is recorded about total packets sent and received, bytes transmitted, and end-to-end delay.
  - An example of using packet tags to track end-to-end delay.
  - A simple control script which runs a number of trials of the experiment at varying distances and queries the resulting database to produce a graph using GNUPlot.

## 25.3 To-Do

High priority items include:

- Inclusion of online statistics code, e.g. for memory efficient confidence intervals.
- Provisions in the data collectors for terminating runs, i.e. when a threshold or confidence is met.
- Data collectors for logging samples over time, and output to the various formats.
- Demonstrate writing simple cyclic event glue to regularly poll some value.

Each of those should prove straightforward to incorporate in the current framework.

## 25.4 Approach

The framework is based around the following core principles:

- One experiment trial is conducted by one instance of a simulation program, whether in parallel or serially.
- A control script executes instances of the simulation, varying parameters as necessary.
- Data is collected and stored for plotting and analysis using external scripts and existing tools.
- Measures within the ns-3 core are taken by connecting the stat framework to existing trace signals.
- Trace signals or direct manipulation of the framework may be used to instrument custom simulation code.

Those basic components of the framework and their interactions are depicted in the following figure.

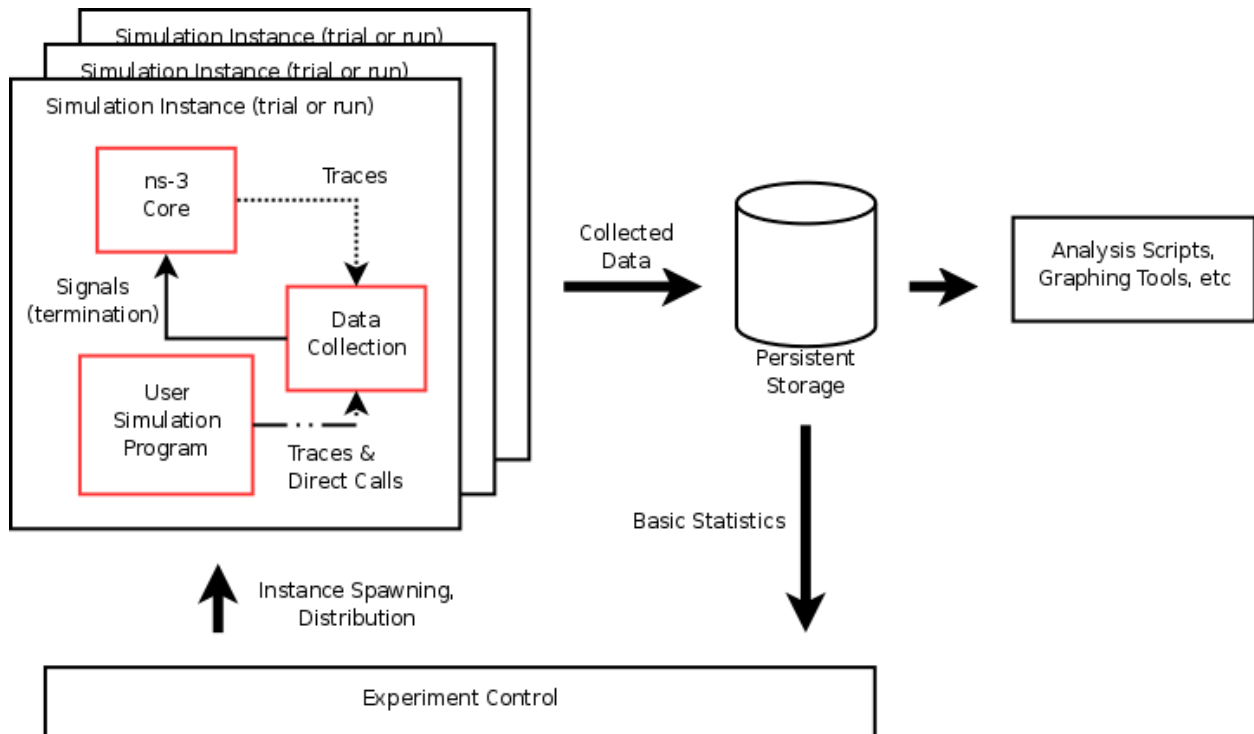

## 25.5 Example

This section goes through the process of constructing an experiment in the framework and producing data for analysis (graphs) from it, demonstrating the structure and API along the way.

### 25.5.1 Question

“What is the (simulated) performance of ns-3’s WiFi NetDevices (using the default settings)? How far apart can wireless nodes be in a simulation before they cannot communicate reliably?”

- Hypothesis: Based on knowledge of real life performance, the nodes should communicate reasonably well to at least 100m apart. Communication beyond 200m shouldn’t be feasible.

Although not a very common question in simulation contexts, this is an important property of which simulation developers should have a basic understanding. It is also a common study done on live hardware.

### 25.5.2 Simulation Program

The first thing to do in implementing this experiment is developing the simulation program. The code for this example can be found in `examples/stats/wifi-example-sim.cc`. It does the following main steps.

- Declaring parameters and parsing the command line using `ns3::CommandLine`.

```
CommandLine cmd;
cmd.AddValue("distance", "Distance apart to place nodes (in meters).",
            distance);
cmd.AddValue("format", "Format to use for data output.",
            format);
cmd.AddValue("experiment", "Identifier for experiment.",
```

```

        experiment);
cmd.AddValue("strategy", "Identifier for strategy.",
            strategy);
cmd.AddValue("run", "Identifier for run.",
            runID);
cmd.Parse (argc, argv);

```

- Creating nodes and network stacks using `ns3::NodeContainer`, `ns3::WiFiHelper`, and `ns3::InternetStackHelper`.

```

NodeContainer nodes;
nodes.Create(2);

WifiHelper wifi;
wifi.SetMac("ns3::AdhocWifiMac");
wifi.SetPhy("ns3::WifiPhy");
NetDeviceContainer nodeDevices = wifi.Install(nodes);

InternetStackHelper internet;
internet.Install(nodes);
Ipv4AddressHelper ipAddrs;
ipAddrs.SetBase("192.168.0.0", "255.255.255.0");
ipAddrs.Assign(nodeDevices);

```

- Positioning the nodes using `ns3::MobilityHelper`. By default the nodes have static mobility and won't move, but must be positioned the given distance apart. There are several ways to do this; it is done here using `ns3::ListPositionAllocator`, which draws positions from a given list.

```

MobilityHelper mobility;
Ptr<ListPositionAllocator> positionAlloc =
    CreateObject<ListPositionAllocator>();
positionAlloc->Add(Vector(0.0, 0.0, 0.0));
positionAlloc->Add(Vector(0.0, distance, 0.0));
mobility.SetPositionAllocator(positionAlloc);
mobility.Install(nodes);

```

- Installing a traffic generator and a traffic sink. The stock Applications could be used, but the example includes custom objects in `src/test/test02-apps.cc|h`. These have a simple behavior, generating a given number of packets spaced at a given interval. As there is only one of each they are installed manually; for a larger set the `ns3::ApplicationHelper` class could be used. The commented-out `Config::Set` line changes the destination of the packets, set to broadcast by default in this example. Note that in general WiFi may have different performance for broadcast and unicast frames due to different rate control and MAC retransmission policies.

```

Ptr<Node> appSource = NodeList::GetNode(0);
Ptr<Sender> sender = CreateObject<Sender>();
appSource->AddApplication(sender);
sender->Start(Seconds(1));

Ptr<Node> appSink = NodeList::GetNode(1);
Ptr<Receiver> receiver = CreateObject<Receiver>();
appSink->AddApplication(receiver);
receiver->Start(Seconds(0));

// Config::Set("/NodeList/*/ApplicationList*/$Sender/Destination",
//             Ipv4AddressValue("192.168.0.2"));

```

- Configuring the data and statistics to be collected. The basic paradigm is that an `ns3::DataCollector` object is created to hold information about this particular run, to which observers and calculators are attached to



actually generate data. Importantly, run information includes labels for the ‘‘experiment’’, ‘‘strategy’’, ‘‘input’’, and ‘‘run’’. These are used to later identify and easily group data from multiple trials.

- The experiment is the study of which this trial is a member. Here it is on WiFi performance and distance.
- The strategy is the code or parameters being examined in this trial. In this example it is fixed, but an obvious extension would be to investigate different WiFi bit rates, each of which would be a different strategy.
- The input is the particular problem given to this trial. Here it is simply the distance between the two nodes.
- The runID is a unique identifier for this trial with which it’s information is tagged for identification in later analysis. If no run ID is given the example program makes a (weak) run ID using the current time.

Those four pieces of metadata are required, but more may be desired. They may be added to the record using the `ns3::DataCollector::AddMetadata()` method.

```
DataCollector data;
data.DescribeRun(experiment,
                 strategy,
                 input,
                 runID);
data.AddMetadata("author", "tjkopena");
```

Actual observation and calculating is done by `ns3::DataCalculator` objects, of which several different types exist. These are created by the simulation program, attached to reporting or sampling code, and then registered with the `ns3::DataCollector` so they will be queried later for their output. One easy observation mechanism is to use existing trace sources, for example to instrument objects in the ns-3 core without changing their code. Here a counter is attached directly to a trace signal in the WiFi MAC layer on the target node.

```
Ptr<PacketCounterCalculator> totalRx =
    CreateObject<PacketCounterCalculator>();
totalRx->SetKey("wifi-rx-frames");
Config::Connect("/NodeList/1/DeviceList/*/ns3::WifiNetDevice/Rx",
                MakeCallback(&PacketCounterCalculator::FrameUpdate,
                             totalRx));
data.AddDataCalculator(totalRx);
```

Calculators may also be manipulated directly. In this example, a counter is created and passed to the traffic sink application to be updated when packets are received.

```
Ptr<CounterCalculator<>> appRx =
    CreateObject<CounterCalculator<>>();
appRx->SetKey("receiver-rx-packets");
receiver->SetCounter(appRx);
data.AddDataCalculator(appRx);
```

To increment the count, the sink’s packet processing code then calls one of the calculator’s update methods.

```
m_calc->Update();
```

The program includes several other examples as well, using both the primitive calculators such as `ns3::CounterCalculator` and those adapted for observing packets and times. In `src/test/test02-apps.cc|h` it also creates a simple custom tag which it uses to track end-to-end delay for generated packets, reporting results to a `ns3::TimeMinMaxAvgTotalCalculator` data calculator.

- Running the simulation, which is very straightforward once constructed.

```
Simulator::Run();
```

- Generating either omnetpp or sqlite output, depending on the command line arguments. To do this a `ns3::DataOutputInterface` object is created and configured. The specific type of this will determine the output format. This object is then given the `ns3::DataCollector` object which it interrogates to produce the output.

```
Ptr<DataOutputInterface> output;
if (format == "omnet") {
    NS_LOG_INFO("Creating omnet formatted data output.");
    output = CreateObject<OmnetDataOutput>();
} else {
    #ifdef STAT_USE_DB
        NS_LOG_INFO("Creating sqlite formatted data output.");
        output = CreateObject<SqliteDataOutput>();
    #endif
}

output->Output(data);
```

- Freeing any memory used by the simulation. This should come at the end of the main function for the example.

```
Simulator::Destroy();
```

## Logging

To see what the example program, applications, and stat framework are doing in detail, set the `NS_LOG` variable appropriately. The following will provide copious output from all three.

```
export NS_LOG=StatFramework:WiFiDistanceExperiment:WiFiDistanceApps
```

Note that this slows down the simulation extraordinarily.

## Sample Output

Compiling and simply running the test program will append omnet++ formatted output such as the following to `data.sca`.

```
run run-1212239121

attr experiment "wifi-distance-test"
attr strategy "wifi-default"
attr input "50"
attr description ""

attr "author" "tjkopena"

scalar wifi-tx-frames count 30
scalar wifi-rx-frames count 30
scalar sender-tx-packets count 30
scalar receiver-rx-packets count 30
scalar tx-pkt-size count 30
scalar tx-pkt-size total 1920
scalar tx-pkt-size average 64
scalar tx-pkt-size max 64
scalar tx-pkt-size min 64
scalar delay count 30
scalar delay total 5884980ns
scalar delay average 196166ns
```

```
scalar delay max 196166ns
scalar delay min 196166ns
```

### 25.5.3 Control Script

In order to automate data collection at a variety of inputs (distances), a simple Bash script is used to execute a series of simulations. It can be found at `examples/stats/wifi-example-db.sh`. The script runs through a set of distances, collecting the results into an sqlite3 database. At each distance five trials are conducted to give a better picture of expected performance. The entire experiment takes only a few dozen seconds to run on a low end machine as there is no output during the simulation and little traffic is generated.

```
#!/bin/sh

DISTANCES="25 50 75 100 125 145 147 150 152 155 157 160 162 165 167 170 172 175 177 180"
TRIALS="1 2 3 4 5"

echo WiFi Experiment Example

if [ -e data.db ]
then
    echo Kill data.db?
    read ANS
    if [ "$ANS" = "yes" -o "$ANS" = "y" ]
    then
        echo Deleting database
        rm data.db
    fi
fi

for trial in $TRIALS
do
    for distance in $DISTANCES
    do
        echo Trial $trial, distance $distance
        ./bin/test02 --format=db --distance=$distance --run=run-$distance-$trial
    done
done
```

### 25.5.4 Analysis and Conclusion

Once all trials have been conducted, the script executes a simple SQL query over the database using the sqlite3 command line program. The query computes average packet loss in each set of trials associated with each distance. It does not take into account different strategies, but the information is present in the database to make some simple extensions and do so. The collected data is then passed to GNUPlot for graphing.

```
CMD="select exp.input,avg(100-((rx.value*100)/tx.value)) \
    from Singletons rx, Singletons tx, Experiments exp \
    where rx.run = tx.run AND \
           rx.run = exp.run AND \
           rx.name='receiver-rx-packets' AND \
           tx.name='sender-tx-packets' \
    group by exp.input \
    order by abs(exp.input) ASC;"
```

```
sqlite3 -noheader data.db "$CMD" > wifi-default.data
```

```
sed -i "s/|/ /" wifi-default.data
gnuplot wifi-example.gnuplot
```

The GNUPlot script found at `examples/stats/wifi-example.gnuplot` simply defines the output format and some basic formatting for the graph.

```
set terminal postscript portrait enhanced lw 2 "Helvetica" 14

set size 1.0, 0.66

#-----
set out "wifi-default.eps"
#set title "Packet Loss Over Distance"
set xlabel "Distance (m) --- average of 5 trials per point"
set xrange [0:200]
set ylabel "% Packet Loss"
set yrange [0:110]

plot "wifi-default.data" with lines title "WiFi Defaults"
```

### End Result

The resulting graph provides no evidence that the default WiFi model's performance is necessarily unreasonable and lends some confidence to an at least token faithfulness to reality. More importantly, this simple investigation has been carried all the way through using the statistical framework. Success!

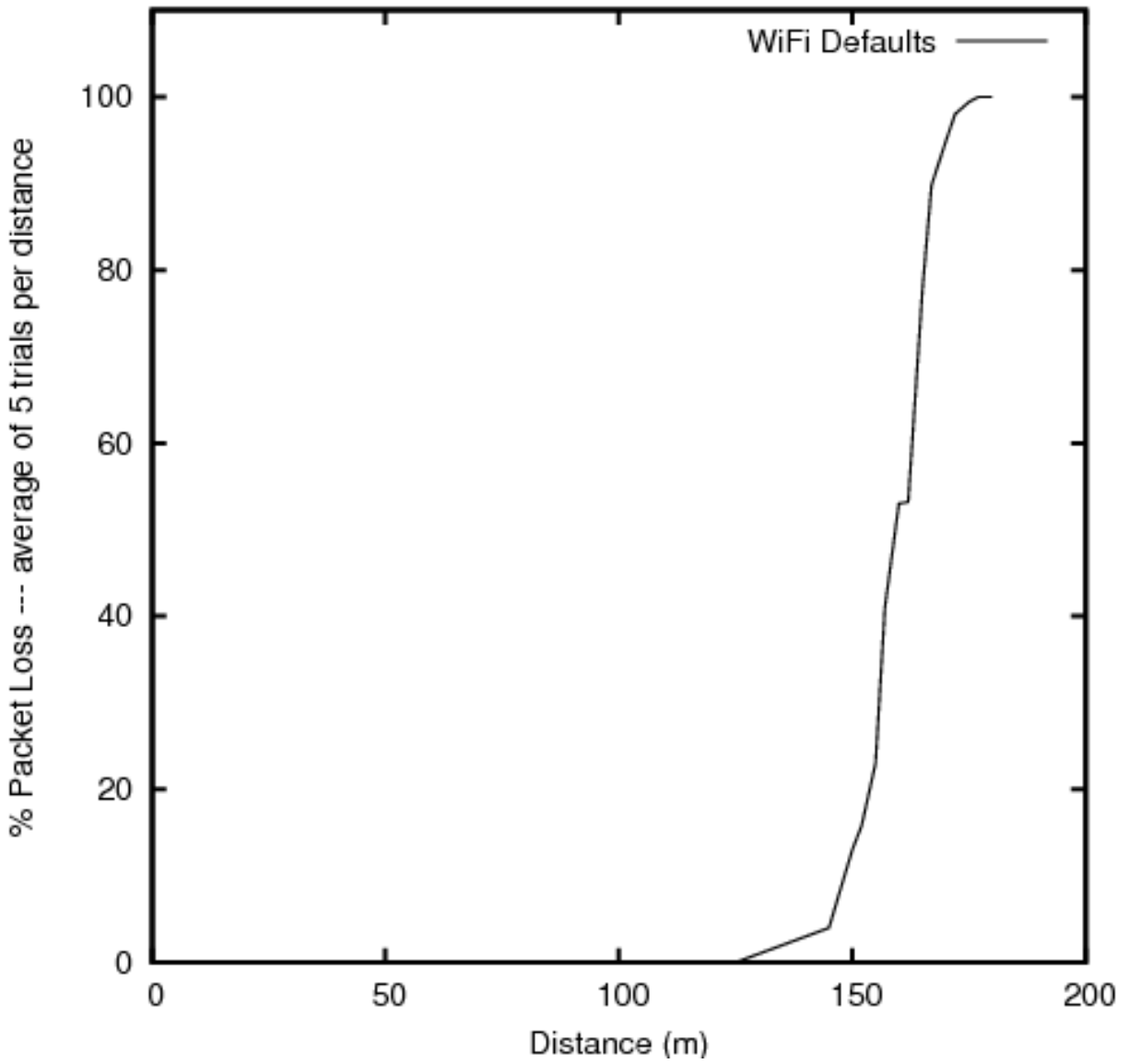



# TOPOLOGY INPUT READERS

The topology modules aim at reading a topology file generated by an automatic topology generator.

The process is divided in two steps:

- running a topology generator to build a topology file
- reading the topology file and build a ns-3 simulation

Hence, model is focused on being able to read correctly the various topology formats.

Currently there are three models:

- `ns3::OrbisTopologyReader` for [Orbis 0.7](#) traces
- `ns3::InetTopologyReader` for [Inet 3.0](#) traces
- `ns3::RocketfuelTopologyReader` for [Rocketfuel](#) traces

An helper `ns3::TopologyReaderHelper` is provided to assist on trivial tasks.

A good source for topology data is also [Archipelago](#).

The current Archipelago [Measurements](#), monthly updated, are stored in the CAIDA website using a complete notation and triple data source, one for each working group.

A different and more compact notation reporting only the AS-relationships (a sort of more Orbis-like format) is here: [as-relationships](#).

The compact notation can be easily stripped down to a pure Orbis format, just removing the double relationships (the compact format use one-way links, while Orbis use two-way links) and pruning the 3rd parameter. Note that with the compact data Orbis can then be used create a rescaled version of the topology, thus being the most effective way (to my best knowledge) to make an internet-like topology.

Examples can be found in the directory `src/topology-read/examples/`





# UAN FRAMEWORK

The main goal of the UAN Framework is to enable researchers to model a variety of underwater network scenarios. The UAN model is broken into four main parts: The channel, PHY, MAC and Autonomous Underwater Vehicle (AUV) models.

The need for underwater wireless communications exists in applications such as remote control in offshore oil industry<sup>1</sup>, pollution monitoring in environmental systems, speech transmission between divers, mapping of the ocean floor, mine counter measures<sup>2</sup>, seismic monitoring of ocean faults as well as climate changes monitoring. Unfortunately, making on-field measurements is very expensive and there are no commonly accepted standard to base on. Hence, the priority to make research work going on, it is to realize a complete simulation framework that researchers can use to experiment, make tests and make performance evaluation and comparison.

The NS-3 UAN module is a first step in this direction, trying to offer a reliable and realistic tool. In fact, the UAN module offers accurate modelling of the underwater acoustic channel, a model of the WHOI acoustic modem (one of the widely used acoustic modems)[6]\_ and its communications performance, and some MAC protocols.

## 27.1 Model Description

The source code for the UAN Framework lives in the directory `src/uan` and in `src/energy` for the contribution on the li-ion battery model.

The UAN Framework is composed of two main parts:

- the AUV mobility models, including Electric motor propelled AUV (REMUS class<sup>3 4</sup>) and Seaglider<sup>4</sup> models
- the energy models, including AUV energy models, AUV energy sources (batteries) and an acoustic modem energy model

As enabling component for the energy models, a Li-Ion batteries energy source has been implemented basing on<sup>5 6</sup>.

---

<sup>1</sup> BINGHAM, D.; DRAKE, T.; HILL, A.; LOTT, R.; The Application of Autonomous Underwater Vehicle (AUV) Technology in the Oil Industry – Vision and Experiences, URL: [http://www.fig.net/pub/fig\\_2002/Ts4-4/TS4\\_4\\_bingham\\_etal.pdf](http://www.fig.net/pub/fig_2002/Ts4-4/TS4_4_bingham_etal.pdf)

<sup>2</sup> WHOI, Autonomous Underwater Vehicle, REMUS; URL: <http://www.whoi.edu/page.do?pid=29856>

<sup>3</sup> Hydroinc Products; URL: <http://www.hydroinc.com/products.html>

<sup>4</sup> Eriksen, C.C., T.J. Osse, R.D. Light, T. Wen, T.W. Lehman, P.L. Sabin, J.W. Ballard, and A.M. Chiodi. Seaglider: A Long-Range Autonomous Underwater Vehicle for Oceanographic Research, IEEE Journal of Oceanic Engineering, 26, 4, October 2001. URL: <http://ieeexplore.ieee.org/stamp/stamp.jsp?tp=&arnumber=972073&userType=inst>

<sup>5</sup> C. M. Shepherd, "Design of Primary and Secondary Cells - Part 3. Battery discharge equation," U.S. Naval Research Laboratory, 1963

<sup>6</sup> Tremblay, O.; Dessaint, L.-A.; Dekkiche, A.-I., "A Generic Battery Model for the Dynamic Simulation of Hybrid Electric Vehicles," Ecole de Technologie Supérieure, Université du Québec, 2007 URL: <http://ieeexplore.ieee.org/stamp/stamp.jsp?tp=&arnumber=4544139>

## 27.1.1 Design

### UAN Propagation Models

Modelling of the underwater acoustic channel has been an active area of research for quite some time. Given the complications involved, surface and bottom interactions, varying speed of sound, etc..., the detailed models in use for ocean acoustics research are much too complex (in terms of runtime) for use in network level simulations. We have attempted to provide the often used models as well as make an attempt to bridge, in part, the gap between complicated ocean acoustic models and network level simulation. The three propagation models included are the ideal channel model, the Thorp propagation model and the Bellhop propagation model (Available as an addition).

All of the Propagation Models follow the same simple interface in `ns3::UanPropModel`. The propagation models provide a power delay profile (PDP) and pathloss information. The PDP is retrieved using the `GetPdp` method which returns type `UanPdp`. `ns3::UanPdp` utilises a tapped delay line model for the acoustic channel. The `UanPdp` class is a container class for Taps, each tap has a delay and amplitude member corresponding to the time of arrival (relative to the first tap arrival time) and amplitude. The propagation model also provides pathloss between the source and receiver in dB re 1uPa. The PDP and pathloss can then be used to find the received signal power over a duration of time (i.e. received signal power in a symbol duration and ISI which interferes with neighbouring signals). Both `UanPropModelIdeal` and `UanPropModelThorp` return a single impulse for a PDP.

#### 1. Ideal Channel Model `ns3::UanPropModelIdeal`

The ideal channel model assumes 0 pathloss inside a cylindrical area with bounds set by attribute. The ideal channel model also assumes an impulse PDP.

#### 2. Thorp Propagation Model `ns3::UanPropModelThorp`

The Thorp Propagation Model calculates pathloss using the well-known Thorp approximation. This model is similar to the underwater channel model implemented in ns2 as described here:

Harris, A. F. and Zorzi, M. 2007. Modeling the underwater acoustic channel in ns2. In Proceedings of the 2nd international Conference on Performance Evaluation Methodologies and Tools (Nantes, France, October 22 - 27, 2007). ValueTools, vol. 321. ICST (Institute for Computer Sciences Social-Informatics and Telecommunications Engineering), ICST, Brussels, Belgium, 1-8.

The frequency used in calculation however, is the center frequency of the modulation as found from `ns3::UanTxMode`. The Thorp Propagation Model also assumes an impulse channel response.

#### 3. Bellhop Propagation Model `ns3::UanPropModelBh` (Available as an addition)

The Bellhop propagation model reads propagation information from a database. A configuration file describing the location, and resolution of the archived information must be supplied via attributes. We have included a utility, `create-dat`, which can create these data files using the Bellhop Acoustic Ray Tracing software (<http://oalib.hlsresearch.com/>).

The `create-dat` utility requires a Bellhop installation to run. Bellhop takes environment information about the channel, such as sound speed profile, surface height bottom type, water depth, and uses a gaussian ray tracing algorithm to determine propagation information. Arrivals from Bellhop are grouped together into equal length taps (the arrivals in a tap duration are coherently summed). The maximum taps are then aligned to take the same position in the PDP. The `create-dat` utility averages together several runs and then normalizes the average such that the sum of all taps is 1. The same configuration file used to create the data files using `create-dat` should be passed via attribute to the Bellhop Propagation Model.

The Bellhop propagation model is available as a patch. The link address will be made available here when it is posted online. Otherwise email [lentracy@gmail.com](mailto:lentracy@gmail.com) for more information.

### UAN PHY Model Overview

The PHY has been designed to allow for relatively easy extension to new networking scenarios. We feel this is important as, to date, there has been no commonly accepted network level simulation model for underwater networks.

The lack of commonly accepted network simulation tools has resulted in a wide array of simulators and models used to report results in literature. The lack of standardization makes comparing results nearly impossible.

The main component of the PHY Model is the generic PHY class, `ns3::UanPhyGen`. The PHY class's general responsibility is to handle packet acquisition, error determination, and forwarding of successful packets up to the MAC layer. The Generic PHY uses two models for determination of signal to noise ratio (SINR) and packet error rate (PER). The combination of the PER and SINR models determine successful reception of packets. The PHY model connects to the channel via a Transducer class. The Transducer class is responsible for tracking all arriving packets and departing packets over the duration of the events. How the PHY class and the PER and SINR models respond to packets is based on the "Mode" of the transmission as described by the `ns3::UanTxMode` class.

When a MAC layer sends down a packet to the PHY for transmission it specifies a "mode number" to be used for the transmission. The PHY class accepts, as an attribute, a list of supported modes. The mode number corresponds to an index in the supported modes. The `UanTxMode` contains simple modulation information and a unique string id. The generic PHY class will only acquire arriving packets which use a mode which is in the supported modes list of the PHY. The mode along with received signal power, and other pertinent attributes (e.g. possibly interfering packets and their modes) are passed to the SINR and PER models for calculation of SINR and probability of error.

Several simple example PER and SINR models have been created. a) The PER models - Default (simple) PER model (`ns3::UanPhyPerGenDefault`): The Default PER model tests the packet against a threshold and assumes error (with prob. 1) if the SINR is below the threshold or success if the SINR is above the threshold - Micromodem FH-FSK PER (`ns3::UanPhyPerUmodem`). The FH-FSK PER model calculates probability of error assuming a rate 1/2 convolutional code with constraint length 9 and a CRC check capable of correcting up to 1 bit error. This is similar to what is used in the receiver of the WHOI Micromodem.

b) SINR models - Default Model (`ns3::UanPhyCalcSinrDefault`), The default SINR model assumes that all transmitted energy is captured at the receiver and that there is no ISI. Any received signal power from interferes acts as additional ambient noise. - FH-FSK SINR Model (`ns3::UanPhyCalcSinrFhFsk`), The WHOI Micromodem operating in FH-FSK mode uses a predetermined hopping pattern that is shared by all nodes in the network. We model this by only including signal energy receiving within one symbol time (as given by `ns3::UanTxMode`) in calculating the received signal power. A channel clearing time is given to the FH-FSK SINR model via attribute. Any signal energy arriving in adjacent signals (after a symbol time and the clearing time) is considered ISI and is treated as additional ambient noise. Interfering signal arrivals inside a symbol time (any symbol time) is also counted as additional ambient noise - Frequency filtered SINR (`ns3::UanPhyCalcSinrDual`). This SINR model calculates SINR in the same manner as the default model. This model however only considers interference if there is an overlap in frequency of the arriving packets as determined by `UanTxMode`.

In addition to the generic PHY a dual phy layer is also included (`ns3::UanPhyDual`). This wraps two generic phy layers together to model a net device which includes two receivers. This was primarily developed for `UanMacRc`, described in the next section.

## UAN MAC Model Overview

Over the last several years there have been a myriad of underwater MAC proposals in the literature. We have included three MAC protocols with this distribution: a) CW-MAC, a MAC protocol which uses a slotted contention window similar in nature to the IEEE 802.11 DCF. Nodes have a constant contention window measured in slot times (configured via attribute). If the channel is sensed busy, then nodes backoff by randomly (uniform distribution) choose a slot to transmit in. The slot time durations are also configured via attribute. This MAC was described in

Parrish N.; Tracy L.; Roy S. Arabshahi P.; and Fox, W., System Design Considerations for Undersea Networks: Link and Multiple Access Protocols, IEEE Journal on Selected Areas in Communications (JSAC), Special Issue on Underwater Wireless Communications and Networks, Dec. 2008.

b) RC-MAC (`ns3::UanMacRc ns3::UanMacRcGw`) a reservation channel protocol which dynamically divides the available bandwidth into a data channel and a control channel. This MAC protocol assumes there is a gateway node which all network traffic is destined for. The current implementation assumes a single gateway and a single network neighborhood (a single hop network). RTS/CTS handshaking is used and time is divided into cycles. Non-gateway

nodes transmit RTS packets on the control channel in parallel to data packet transmissions which were scheduled in the previous cycle at the start of a new cycle, the gateway responds on the data channel with a CTS packet which includes packet transmission times of data packets for received RTS packets in the previous cycle as well as bandwidth allocation information. At the end of a cycle ACK packets are transmitted for received data packets.

When a publication is available it will be cited here.

3. Simple ALOHA (ns3 : :UanMacAloha) Nodes transmit at will.

## AUV mobility models

The AUV mobility models have been designed as in the follows.

### Use cases

The user will be able to:

- program the AUV to navigate over a path of waypoints
- control the velocity of the AUV
- control the depth of the AUV
- control the direction of the AUV
- control the pitch of the AUV
- tell the AUV to emerge or submerge to a specified depth

### AUV mobility models design

Implement a model of the navigation of AUV. This involves implementing two classes modelling the two major categories of AUVs: electric motor propelled (like REMUS class<sup>3 4</sup>) and “sea gliders”<sup>5</sup>. The classic AUVs are submarine-like devices, propelled by an electric motor linked with a propeller. Instead, the “sea glider” class exploits small changes in its buoyancy that, in conjunction with wings, can convert vertical motion to horizontal. So, a glider will reach a point into the water by describing a “saw-tooth” movement. Modelling the AUV navigation, involves in considering a real-world AUV class thus, taking into account maximum speed, directional capabilities, emerging and submerging times. Regarding the sea gliders, it is modelled the characteristic saw-tooth movement, with AUV’s speed driven by buoyancy and glide angle.

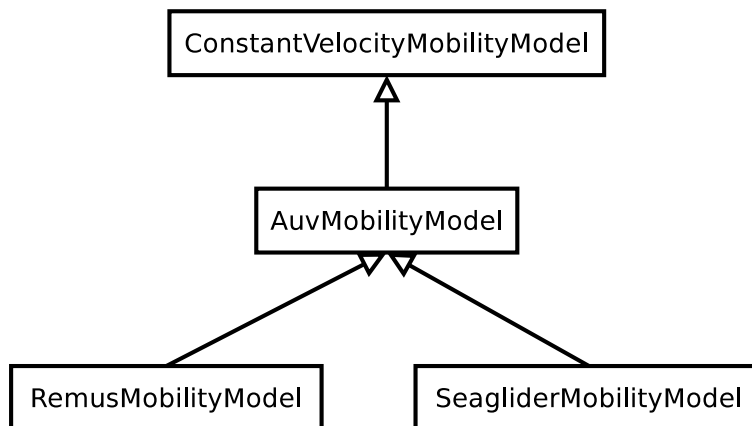

Figure 27.1: AUV’s mobility model classes overview

An `ns3::AuvMobilityModel` interface has been designed to give users a generic interface to access AUV's navigation functions. The `AuvMobilityModel` interface is implemented by the `RemusMobilityModel` and the `GliderMobilityModel` classes. The AUV's mobility models organization it is shown in [AUV's mobility model classes overview](#). Both models use a constant velocity movement, thus the `AuvMobilityModel` interface derives from the `ConstantVelocityMobilityModel`. The two classes hold the navigation parameters for the two different AUVs, like maximum pitch angles, maximum operating depth, maximum and minimum speed values. The `Glider` model holds also some extra parameters like maximum buoyancy values, and maximum and minimum glide slopes. Both classes, `RemusMobilityModel` and `GliderMobilityModel`, handle also the AUV power consumption, utilizing the relative power models. Has been modified the `WaypointMobilityModel` to let it use a generic underlying `ConstantVelocityModel` to validate the waypoints and, to keep trace of the node's position. The default model is the classic `ConstantVelocityModel` but, for example in case of REMUS mobility model, the user can install the AUV mobility model into the waypoint model and then validating the waypoints against REMUS navigation constraints.

## Energy models

The energy models have been designed as in the follows.

### Use cases

The user will be able to:

- use a specific power profile for the acoustic modem
- use a specific energy model for the AUV
- trace the power consumption of AUV navigation, through AUV's energy model
- trace the power consumption underwater acoustic communications, through acoustic modem power profile

We have integrated the Energy Model with the UAN module, to implement energy handling. We have implemented a specific energy model for the two AUV classes and, an energy source for Lithium batteries. This will be really useful for researchers to keep trace of the AUV operational life. We have implemented also an acoustic modem power profile, to keep trace of its power consumption. This can be used to compare protocols specific power performance. In order to use such power profile, the acoustic transducer physical layer has been modified to use the modem power profile. We have decoupled the physical layer from the transducer specific energy model, to let the users change the different energy models without changing the physical layer.

### AUV energy models

Basing on the Device Energy Model interface, it has been implemented a specific energy model for the two AUV classes (REMUS and Seaglider). This models reproduce the AUV's specific power consumption to give users accurate information. This model can be naturally used to evaluates the AUV operating life, as well as mission-related power consumption, etc. Have been developed two AUV energy models:

- `GliderEnergyModel`, computes the power consumption of the vehicle based on the current buoyancy value and vertical speed<sup>5</sup>
- `RemusEnergyModel`, computes the power consumption of the vehicle based on the current speed, as it is propelled by a brush-less electric motor

---

**Note:** TODO extend a little bit

---

## AUV energy sources

---

**Note:** [TODO]

---

### Acoustic modem energy model

Basing on the Device Energy Model interface, has been implemented a generic energy model for acoustic modem. The model allows to trace four modem's power-states: Sleep, Idle, Receiving, Transmitting. The default parameters for the energy model are set to fit those of the WHOI  $\mu$ modem. The class follows pretty closely the RadioEnergyModel class as the transducer behaviour is pretty close to that of a wifi radio.

The default power consumption values implemented into the model are as follows [6]:

Modem State	Power Consumption
TX	50 W
RX	158 mW
Idle	158 mW
Sleep	5.8 mW

### UAN module energy modifications

The UAN module has been modified in order to utilize the implemented energy classes. Specifically, it has been modified the physical layer of the UAN module. It Has been implemented an UpdatePowerConsumption method that takes the modem's state as parameter. It checks if an energy source is installed into the node and, in case, it then use the AcousticModemEnergyModel to update the power consumption with the current modem's state. The modem power consumption's update takes place whenever the modem changes its state.

A user should take into account that, if the the power consumption handling is enabled (if the node has an energy source installed), all the communications processes will terminate whether the node depletes all the energy source.

### Li-Ion batteries model

A generic Li-Ion battery model has been implemented based on [7][8]. The model can be fitted to any type of Li-Ion battery simply changing the model's parameters The default values are fitted for the Panasonic CGR18650DA Li-Ion Battery [9]. [TODO insert figure] As shown in figure the model approximates very well the Li-Ion cells. Regarding Seagliders, the batteries used into the AUV are Electrochem 3B36 Lithium / Sulfuryl Chloride cells [10]. Also with this cell type, the model seems to approximates the different discharge curves pretty well, as shown in the figure.

---

**Note:** should I insert the li-ion model deatils here? I think it is better to put them into an Energy-related chapter..

---

## 27.1.2 Scope and Limitations

The framework is designed to simulate AUV's behaviour. We have modeled the navigation and power consumption behaviour of REMUS class and Seaglider AUVs. The communications stack, associated with the AUV, can be modified depending on simulation needs. Usually, the default underwater stack is being used, composed of an half duplex acoustic modem, an Aloha MAC protocol and a generic physical layer.

Regarding the AUV energy consumption, the user should be aware that the level of accuracy differs for the two classes:

- Seaglider, high level of accuracy, thanks to the availability of detailed information on AUV's components and behaviour [5] [10]. Have been modeled both the navigation power consumption and the Li battery packs (according to [5]).
- REMUS, medium level of accuracy, due to the lack of publicly available information on AUV's components. We have approximated the power consumption of the AUV's motor with a linear behaviour and, the energy source uses an ideal model (BasicEnergySource) with a power capacity equal to that specified in [4].

### 27.1.3 Future Work

Some ideas could be :

- insert a data logging capability
- modify the framework to use sockets (enabling the possibility to use applications)
- introduce some more MAC protocols
- modify the physical layer to let it consider the doppler spread (problematic in underwater environments)
- introduce OFDM modulations

### 27.1.4 References

## 27.2 Usage

The main way that users who write simulation scripts will typically interact with the UAN Framework is through the helper API and through the publicly visible attributes of the model.

The helper API is defined in `src/uan/helper/acoustic-modem-energy-model-helper.{cc,h}` and in `/src/uan/helper/...{cc,h}`.

The example folder `src/uan/examples/` contain some basic code that shows how to set up and use the models. further examples can be found into the Unit tests in `src/uan/test/...cc`

### 27.2.1 Examples

Examples of the Framework's usage can be found into the examples folder. There are mobility related examples and uan related ones.

#### Mobility Model Examples

- **auv-energy-model:** In this example we show the basic usage of an AUV energy model. Specifically, we show how to create a generic node, adding to it a basic energy source and consuming energy from the energy source. In this example we show the basic usage of an AUV energy model.

The Seaglider AUV power consumption depends on buoyancy and vertical speed values, so we simulate a 20 seconds movement at 0.3 m/s of vertical speed and 138g of buoyancy. Then a 20 seconds movement at 0.2 m/s of vertical speed and 138g of buoyancy and then a stop of 5 seconds.

The required energy will be drained by the model basing on the given buoyancy/speed values, from the energy source installed onto the node. We finally register a callback to the TotalEnergyConsumption traced value.

- **auv-mobility:** In this example we show how to use the `AuvMobilityHelper` to install an AUV mobility model into a (set of) node. Then we make the AUV to submerge to a depth of 1000 meters. We then set a callback function called on reaching of the target depth. The callback then makes the AUV to emerge to water surface (0 meters). We set also a callback function called on reaching of the target depth. The emerge callback then, stops the AUV.

During the whole navigation process, the AUV's position is tracked by the `TracePos` function and plotted into a Gnuplot graph.

- **waypoint-mobility:** We show how to use the `WaypointMobilityModel` with a non-standard `ConstantVelocityMobilityModel`. We first create a waypoint model with an underlying `RemusMobilityModel` setting the mobility trace with two waypoints. We then create a waypoint model with an underlying `GliderMobilityModel` setting the waypoints separately with the `AddWaypoint` method. The AUV's position is printed out every seconds.

## UAN Examples

- **li-ion-energy-source** In this simple example, we show how to create and drain energy from a `LiIonEnergySource`. We make a series of discharge calls to the energy source class, with different current drain and durations, until all the energy is depleted from the cell (i.e. the voltage of the cell goes below the threshold level). Every 20 seconds we print out the actual cell voltage to verify that it follows the discharge curve [9]. At the end of the example it is verified that after the energy depletion call, the cell voltage is below the threshold voltage.
- **uan-energy-auv** This is a comprehensive example where all the project's components are used. We setup two nodes, one fixed surface gateway equipped with an acoustic modem and a moving Seaglider AUV with an acoustic modem too. Using the waypoint mobility model with an underlying `GliderMobilityModel`, we make the glider descend to -1000 meters and then emerge to the water surface. The AUV sends a generic 17-bytes packet every 10 seconds during the navigation process. The gateway receives the packets and stores the total bytes amount. At the end of the simulation are shown the energy consumptions of the two nodes and the networking stats.

## 27.2.2 Helpers

In this section we give an overview of the available helpers and their behaviour.

### AcousticModemEnergyModelHelper

This helper installs `AcousticModemEnergyModel` into `UanNetDevice` objects only. It requires an `UanNetDevice` and an `EnergySource` as input objects.

The helper creates an `AcousticModemEnergyModel` with default parameters and associate it with the given energy source. It configures an `EnergyModelCallback` and an `EnergyDepletionCallback`. The depletion callback can be configured as a parameter.

### AuvGliderHelper

Installs into a node (or set of nodes) the Seaglider's features:

- waypoint model with underlying glider mobility model
- glider energy model
- glider energy source



- micro modem energy model

The glider mobility model is the `GliderMobilityModel` with default parameters. The glider energy model is the `GliderEnergyModel` with default parameters.

Regarding the energy source, the Seaglider features two battery packs, one for motor power and one for digital-analog power. Each pack is composed of 12 (10V) and 42 (24V) lithium chloride DD-cell batteries, respectively [5]. The total power capacity is around 17.5 MJ (3.9 MJ + 13.6 MJ). In the original version of the Seaglider there was 18 + 63 D-cell with a total power capacity of 10MJ.

The packs design is as follows:

- 10V - 3 in-series string x 4 strings = 12 cells - typical capacity ~100 Ah
- 24V - 7 in-series-strings x 6 strings = 42 cells - typical capacity ~150 Ah

Battery cells are Electrochem 3B36, with 3.6 V nominal voltage and 30.0 Ah nominal capacity. The 10V battery pack is associated with the electronic devices, while the 24V one is associated with the pump motor.

The micro modem energy model is the `MicroModemEnergyModel` with default parameters.

## AuvRemusHelper

Install into a node (or set of nodes) the REMUS features:

- waypoint model with REMUS mobility model validation
- REMUS energy model
- REMUS energy source
- micro modem energy model

The REMUS mobility model is the `RemusMobilityModel` with default parameters. The REMUS energy model is the `RemusEnergyModel` with default parameters.

Regarding the energy source, the REMUS features a rechargeable lithium ion battery pack rated 1.1 kWh @ 27 V (40 Ah) in operating conditions (specifications from [3] and Hydroinc European salesman). Since more detailed information about battery pack were not publicly available, the energy source used is a `BasicEnergySource`.

The micro modem energy model is the `MicroModemEnergyModel` with default parameters.

### 27.2.3 Attributes

---

**Note:** TODO

---

### 27.2.4 Tracing

---

**Note:** TODO

---

### 27.2.5 Logging

---

**Note:** TODO

---

## 27.2.6 Caveats

---

**Note:** TODO

---

## 27.3 Validation

This model has been tested with three UNIT test:

- auv-energy-model
- auv-mobility
- li-ion-energy-source

### 27.3.1 Auv Energy Model

Includes test cases for single packet energy consumption, energy depletion, Glider and REMUS energy consumption. The unit test can be found in `src/uan/test/auv-energy-model-test.cc`.

The single packet energy consumption test do the following:

- creates a two node network, one surface gateway and one fixed node at -500 m of depth
- install the acoustic communication stack with energy consumption support into the nodes
- a packet is sent from the underwater node to the gateway
- it is verified that both, the gateway and the fixed node, have consumed the expected amount of energy from their sources

The energy depletion test do the following steps:

- create a node with an empty energy source
- try to send a packet
- verify that the energy depletion callback has been invoked

The Glider energy consumption test do the following:

- create a node with glider capabilities
- make the vehicle to move to a predetermined waypoint
- verify that the energy consumed for the navigation is correct, according to the glider specifications

The REMUS energy consumption test do the following:

- create a node with REMUS capabilities
- make the vehicle to move to a predetermined waypoint
- verify that the energy consumed for the navigation is correct, according to the REMUS specifications

### 27.3.2 Auv Mobility

Includes test cases for glider and REMUS mobility models. The unit test can be found in `src/uan/test/auv-mobility-test.cc`.

- create a node with glider capabilities
- set a specified velocity vector and verify if the resulting buoyancy is the one that is supposed to be
- make the vehicle to submerge to a specified depth and verify if, at the end of the process the position is the one that is supposed to be
- make the vehicle to emerge to a specified depth and verify if, at the end of the process the position is the one that is supposed to be
- make the vehicle to navigate to a specified point, using direction, pitch and speed settings and, verify if at the end of the process the position is the one that is supposed to be
- make the vehicle to navigate to a specified point, using a velocity vector and, verify if at the end of the process the position is the one that is supposed to be

The REMUS mobility model test do the following: \* create a node with glider capabilities \* make the vehicle to submerge to a specified depth and verify if, at the end of the process the position is the one that is supposed to be \* make the vehicle to emerge to a specified depth and verify if, at the end of the process the position is the one that is supposed to be \* make the vehicle to navigate to a specified point, using direction, pitch and speed settings and, verify if at the end of the process the position is the one that is supposed to be \* make the vehicle to navigate to a specified point, using a velocity vector and, verify if at the end of the process the position is the one that is supposed to be

### 27.3.3 Li-Ion Energy Source

Includes test case for Li-Ion energy source. The unit test can be found in `src/energy/test/li-ion-energy-source-test.cc`.

The test case verify that after a well-known discharge time with constant current drain, the cell voltage has followed the datasheet discharge curve [9].



# WIFI

*ns-3* nodes can contain a collection of `NetDevice` objects, much like an actual computer contains separate interface cards for Ethernet, Wifi, Bluetooth, etc. This chapter describes the *ns-3* `WifiNetDevice` and related models. By adding `WifiNetDevice` objects to *ns-3* nodes, one can create models of 802.11-based infrastructure and ad hoc networks.

## 28.1 Overview of the model

The `WifiNetDevice` models a wireless network interface controller based on the IEEE 802.11 standard [ieee80211]. We will go into more detail below but in brief, *ns-3* provides models for these aspects of 802.11:

- basic 802.11 DCF with **infrastructure** and **adhoc** modes
- **802.11a**, **802.11b** and **802.11g** physical layers
- QoS-based EDCA and queueing extensions of **802.11e**
- various propagation loss models including **Nakagami**, **Rayleigh**, **Friis**, **LogDistance**, **FixedRss**, **Random**
- two propagation delay models, a distance-based and random model
- various rate control algorithms including **Aarf**, **Arf**, **Cara**, **Onoe**, **Rraa**, **ConstantRate**, and **Minstrel**
- 802.11s (mesh), described in another chapter

The set of 802.11 models provided in *ns-3* attempts to provide an accurate MAC-level implementation of the 802.11 specification and to provide a not-so-slow PHY-level model of the 802.11a specification.

The implementation is modular and provides roughly four levels of models:

- the **PHY layer models**
- the so-called **MAC low models**: they implement DCF and EDCAF
- the so-called **MAC high models**: they implement the MAC-level beacon generation, probing, and association state machines, and
- a set of **Rate control algorithms** used by the MAC low models

There are presently three **MAC high models** that provide for the three (non-mesh; the mesh equivalent, which is a sibling of these with common parent `ns3::RegularWifiMac`, is not discussed here) Wi-Fi topological elements - Access Point (AP) (implemented in class `ns3::ApWifiMac`, non-AP Station (STA) (`ns3::StaWifiMac`), and STA in an Independent Basic Service Set (IBSS - also commonly referred to as an ad hoc network (`ns3::AdhocWifiMac`).

The simplest of these is `ns3::AdhocWifiMac`, which implements a Wi-Fi MAC that does not perform any kind of beacon generation, probing, or association. The `ns3::StaWifiMac` class implements an active probing and

association state machine that handles automatic re-association whenever too many beacons are missed. Finally, `ns3::ApWifiMac` implements an AP that generates periodic beacons, and that accepts every attempt to associate.

These three MAC high models share a common parent in `ns3::RegularWifiMac`, which exposes, among other MAC configuration, an attribute `QoSSupported` that allows configuration of 802.11e/WMM-style QoS support. With QoS-enabled MAC models it is possible to work with traffic belonging to four different Access Categories (ACs): **AC\_VO** for voice traffic, **AC\_VI** for video traffic, **AC\_BE** for best-effort traffic and **AC\_BK** for background traffic. In order for the MAC to determine the appropriate AC for an MSDU, packets forwarded down to these MAC layers should be marked using `ns3::QoSTag` in order to set a TID (traffic id) for that packet otherwise it will be considered belonging to **AC\_BE**.

The **MAC low layer** is split into three components:

1. `ns3::MacLow` which takes care of RTS/CTS/DATA/ACK transactions.
2. `ns3::DcfManager` and `ns3::DcfState` which implements the DCF and EDCAF functions.
3. `ns3::DcaTxop` and `ns3::EdcaTxopN` which handle the packet queue, packet fragmentation, and packet retransmissions if they are needed. The `ns3::DcaTxop` object is used high MACs that are not QoS-enabled, and for transmission of frames (e.g., of type Management) that the standard says should access the medium using the DCF. `ns3::EdcaTxopN` is used by QoS-enabled high MACs and also performs QoS operations like 802.11n-style MSDU aggregation.

There are also several **rate control algorithms** that can be used by the Mac low layer:

- `OnoeWifiManager`
- `IdealWifiManager`
- `AarfcdWifiManager`
- `AarfWifiManager`
- `ArfWifiManager`
- `AmrrWifiManager`
- `ConstantRateWifiManager`
- `MinstrelWifiManager`
- `CaraWifiManager`
- `RraaWifiManager`

The PHY layer implements a single model in the `ns3::WifiPhy` class: the physical layer model implemented there is described fully in a paper entitled [Yet Another Network Simulator](#) Validation results for 802.11b are available in this [technical report](#)

In *ns-3*, nodes can have multiple `WifiNetDevices` on separate channels, and the `WifiNetDevice` can coexist with other device types; this removes an architectural limitation found in *ns-2*. Presently, however, there is no model for cross-channel interference or coupling.

The source code for the `WifiNetDevice` lives in the directory `src/wifi`.

## 28.2 Using the `WifiNetDevice`

The modularity provided by the implementation makes low-level configuration of the `WifiNetDevice` powerful but complex. For this reason, we provide some helper classes to perform common operations in a simple matter, and leverage the *ns-3* attribute system to allow users to control the parametrization of the underlying models.

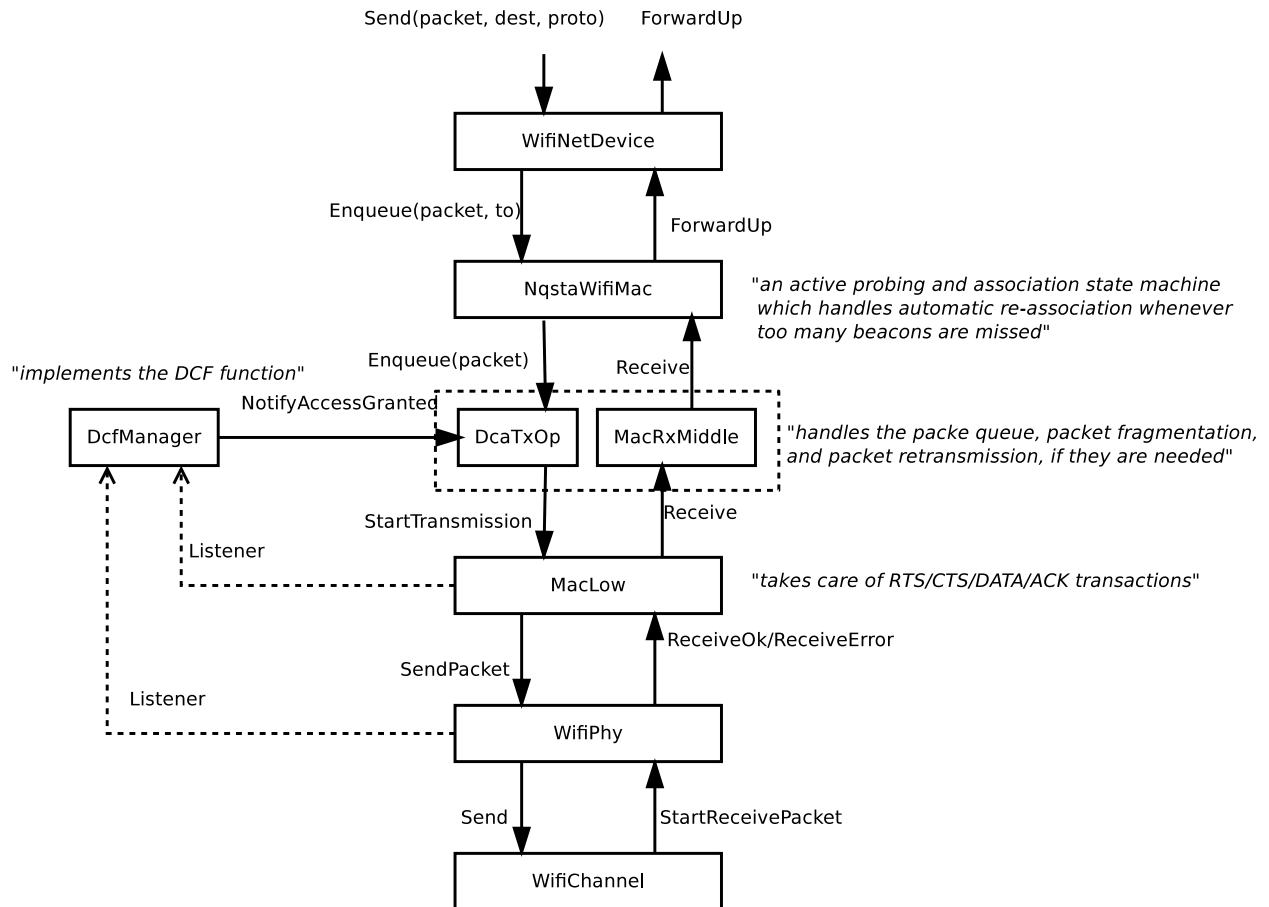

Figure 28.1: Wifi NetDevice architecture.

Users who use the low-level *ns-3* API and who wish to add a `WifiNetDevice` to their node must create an instance of a `WifiNetDevice`, plus a number of constituent objects, and bind them together appropriately (the `WifiNetDevice` is very modular in this regard, for future extensibility). At the low-level API, this can be done with about 20 lines of code (see `ns3::WifiHelper::Install`, and `ns3::YansWifiPhyHelper::Create`). They also must create, at some point, a `WifiChannel`, which also contains a number of constituent objects (see `ns3::YansWifiChannelHelper::Create`).

However, a few helpers are available for users to add these devices and channels with only a few lines of code, if they are willing to use defaults, and the helpers provide additional API to allow the passing of attribute values to change default values. The scripts in `src/examples` can be browsed to see how this is done.

### 28.2.1 YansWifiChannelHelper

The `YansWifiChannelHelper` has an unusual name. Readers may wonder why it is named this way. The reference is to the [yans simulator](#) from which this model is taken. The helper can be used to create a `WifiChannel` with a default `PropagationLoss` and `PropagationDelay` model. Specifically, the default is a channel model with a propagation delay equal to a constant, the speed of light, and a propagation loss based on a log distance model with a reference loss of 46.6777 dB at reference distance of 1m.

Users will typically type code such as::

```
YansWifiChannelHelper wifiChannelHelper = YansWifiChannelHelper::Default ();
Ptr<WifiChannel> wifiChannel = wifiChannelHelper.Create ();
```

to get the defaults. Note the distinction above in creating a helper object vs. an actual simulation object. In *ns-3*, helper objects (used at the helper API only) are created on the stack (they could also be created with operator `new` and later deleted). However, the actual *ns-3* objects typically inherit from `class ns3::Object` and are assigned to a smart pointer. See the chapter in the *ns-3* manual for a discussion of the *ns-3* object model, if you are not familiar with it.

*Todo: Add notes about how to configure attributes with this helper API*

### 28.2.2 YansWifiPhyHelper

Physical devices (base class `ns3::Phy`) connect to `ns3::Channel` models in *ns-3*. We need to create `Phy` objects appropriate for the `YansWifiChannel`; here the `YansWifiPhyHelper` will do the work.

The `YansWifiPhyHelper` class configures an object factory to create instances of a `YansWifiPhy` and adds some other objects to it, including possibly a supplemental `ErrorRateModel` and a pointer to a `MobilityModel`. The user code is typically::

```
YansWifiPhyHelper wifiPhyHelper = YansWifiPhyHelper::Default ();
wifiPhyHelper.SetChannel (wifiChannel);
```

Note that we haven't actually created any `WifiPhy` objects yet; we've just prepared the `YansWifiPhyHelper` by telling it which channel it is connected to. The `phy` objects are created in the next step.

### 28.2.3 NqosWifiMacHelper and QosWifiMacHelper

The `ns3::NqosWifiMacHelper` and `ns3::QosWifiMacHelper` configure an object factory to create instances of a `ns3::WifiMac`. They are used to configure MAC parameters like type of MAC.

The former, `ns3::NqosWifiMacHelper`, supports creation of MAC instances that do not have 802.11e/WMM-style QoS support enabled.



For example the following user code configures a non-QoS MAC that will be a non-AP STA in an infrastructure network where the AP has SSID ns-3-ssid::

```
NqosWifiMacHelper wifiMacHelper = NqosWifiMacHelper::Default ();
Ssid ssid = Ssid ("ns-3-ssid");
wifiMacHelper.SetType ("ns3::StaWifiMac",
                      "Ssid", SsidValue (ssid),
                      "ActiveProbing", BooleanValue (false));
```

To create MAC instances with QoS support enabled, ns3::QosWifiMacHelper is used in place of ns3::NqosWifiMacHelper. This object can be also used to set:

- a MSDU aggregator for a particular Access Category (AC) in order to use 802.11n MSDU aggregation feature;
- block ack parameters like threshold (number of packets for which block ack mechanism should be used) and inactivity timeout.

The following code shows an example use of ns3::QosWifiMacHelper to create an AP with QoS enabled, aggregation on AC\_VO, and Block Ack on AC\_BE::

```
QosWifiMacHelper wifiMacHelper = QosWifiMacHelper::Default ();
wifiMacHelper.SetType ("ns3::ApWifiMac",
                      "Ssid", SsidValue (ssid),
                      "BeaconGeneration", BooleanValue (true),
                      "BeaconInterval", TimeValue (Seconds (2.5)));
wifiMacHelper.SetMsduAggregatorForAc (AC_VO, "ns3::MsduStandardAggregator",
                                      "MaxAmsduSize", UIntegerValue (3839));
wifiMacHelper.SetBlockAckThresholdForAc (AC_BE, 10);
wifiMacHelper.SetBlockAckInactivityTimeoutForAc (AC_BE, 5);
```

## 28.2.4 WifiHelper

We're now ready to create WifiNetDevices. First, let's create a WifiHelper with default settings::

```
WifiHelper wifiHelper = WifiHelper::Default ();
```

What does this do? It sets the RemoteStationManager to ns3::ArfWifiManager. Now, let's use the wifiPhyHelper and wifiMacHelper created above to install WifiNetDevices on a set of nodes in a NodeContainer "c":

```
NetDeviceContainer wifiContainer = WifiHelper::Install (wifiPhyHelper, wifiMacHelper, c);
```

This creates the WifiNetDevice which includes also a WifiRemoteStationManager, a WifiMac, and a WifiPhy (connected to the matching WifiChannel).

There are many ns-3 attributes that can be set on the above helpers to deviate from the default behavior; the example scripts show how to do some of this reconfiguration.

## 28.2.5 AdHoc WifiNetDevice configuration

This is a typical example of how a user might configure an adhoc network.

*To be completed*

## 28.2.6 Infrastructure (Access Point and clients) WifiNetDevice configuration

This is a typical example of how a user might configure an access point and a set of clients.

*To be completed*

## 28.3 The WifiChannel and WifiPhy models

The WifiChannel subclass can be used to connect together a set of `ns3::WifiNetDevice` network interfaces. The class `ns3::WifiPhy` is the object within the WifiNetDevice that receives bits from the channel. For the channel propagation modeling, the propagation module is used; see section *Propagation* for details.

This section summarizes the description of the BER calculations found in the yans paper taking into account the Forward Error Correction present in 802.11a and describes the algorithm we implemented to decide whether or not a packet can be successfully received. See “Yet Another Network Simulator” for more details.

The PHY layer can be in one of three states:

1. TX: the PHY is currently transmitting a signal on behalf of its associated MAC
2. RX: the PHY is synchronized on a signal and is waiting until it has received its last bit to forward it to the MAC.
3. IDLE: the PHY is not in the TX or RX states.

When the first bit of a new packet is received while the PHY is not IDLE (that is, it is already synchronized on the reception of another earlier packet or it is sending data itself), the received packet is dropped. Otherwise, if the PHY is IDLE, we calculate the received energy of the first bit of this new signal and compare it against our Energy Detection threshold (as defined by the Clear Channel Assessment function mode 1). If the energy of the packet  $k$  is higher, then the PHY moves to RX state and schedules an event when the last bit of the packet is expected to be received. Otherwise, the PHY stays in IDLE state and drops the packet.

The energy of the received signal is assumed to be zero outside of the reception interval of packet  $k$  and is calculated from the transmission power with a path-loss propagation model in the reception interval. where the path loss exponent,  $n$ , is chosen equal to 3, the reference distance,  $d_0$  is chosen equal to  $1.0m$  and the reference energy is based on a Friis propagation model.

When the last bit of the packet upon which the PHY is synchronized is received, we need to calculate the probability that the packet is received with any error to decide whether or not the packet on which we were synchronized could be successfully received or not: a random number is drawn from a uniform distribution and is compared against the probability of error.

To evaluate the probability of error, we start from the piecewise linear functions shown in Figure *SNIR function over time*. and calculate the SNIR function.

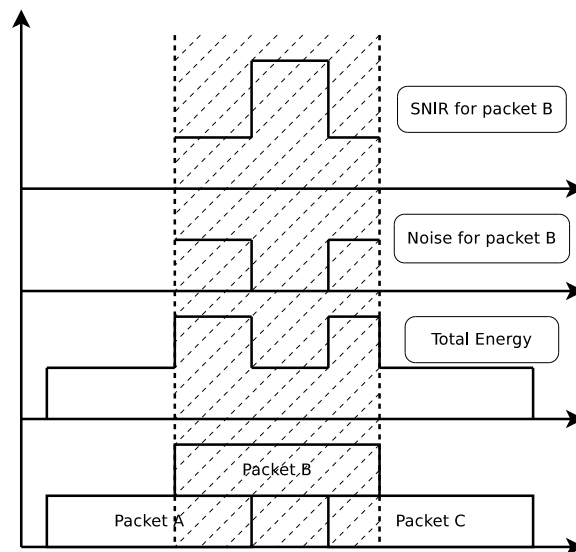

Figure 28.2: SNIR function over time.

From the SNIR function we can derive the Bit Error Rate (BER) and Packet Error Rate (PER) for the modulation and coding scheme being used for the transmission. Please refer to [pei80211ofdm], [pei80211b] and [lacage2006yans] for a detailed description of the available BER/PER models.

### 28.3.1 WifiChannel configuration

The WifiChannel implementation uses the propagation loss and delay models provided within the ns-3 *propagation* module.

## 28.4 The MAC model

The 802.11 Distributed Coordination Function is used to calculate when to grant access to the transmission medium. While implementing the DCF would have been particularly easy if we had used a recurring timer that expired every slot, we chose to use the method described in [ji2004sslswn] where the backoff timer duration is lazily calculated whenever needed since it is claimed to have much better performance than the simpler recurring timer solution.

The backoff procedure of DCF is described in section 9.2.5.2 of [ieee80211].

- “The backoff procedure shall be invoked for a STA to transfer a frame when finding the medium busy as indicated by either the physical or virtual CS mechanism.”
- “A backoff procedure shall be performed immediately after the end of every transmission with the More Fragments bit set to 0 of an MPDU of type Data, Management, or Control with subtype PS-Poll, even if no additional transmissions are currently queued.”

Thus, if the queue is empty, a newly arrived packet should be transmitted immediately after channel is sensed idle for DIFS. If queue is not empty and after a successful MPDU that has no more fragments, a node should also start the backoff timer.

Some users have observed that the 802.11 MAC with an empty queue on an idle channel will transmit the first frame arriving to the model immediately without waiting for DIFS or backoff, and wonder whether this is compliant. According to the standard, “The backoff procedure shall be invoked for a STA to transfer a frame when finding the medium busy as indicated by either the physical or virtual CS mechanism.” So in this case, the medium is not found to be busy in recent past and the station can transmit immediately.

The higher-level MAC functions are implemented in a set of other C++ classes and deal with:

- packet fragmentation and defragmentation,
- use of the rts/cts protocol,
- rate control algorithm,
- connection and disconnection to and from an Access Point,
- the MAC transmission queue,
- beacon generation,
- msdu aggregation,
- etc.

## 28.5 Wifi Attributes

Should link to the list of attributes exported by Doxygen

## 28.6 Wifi Tracing

Should link to the list of traces exported by Doxygen

## 28.7 References

# WIMAX NETDEVICE

This chapter describes the *ns-3* WimaxNetDevice and related models. By adding WimaxNetDevice objects to *ns-3* nodes, one can create models of 802.16-based networks. Below, we list some more details about what the *ns-3* WiMAX models cover but, in summary, the most important features of the *ns-3* model are:

- a scalable and realistic physical layer and channel model
- a packet classifier for the IP convergence sublayer
- efficient uplink and downlink schedulers
- support for Multicast and Broadcast Service (MBS), and
- packet tracing functionality

The source code for the WiMAX models lives in the directory `src/wimax`.

There have been two academic papers published on this model:

- M.A. Ismail, G. Piro, L.A. Grieco, and T. Turletti, “An Improved IEEE 802.16 WiMAX Module for the NS-3 Simulator”, SIMUTools 2010 Conference, March 2010.
- J. Farooq and T. Turletti, “An IEEE 802.16 WiMAX module for the NS-3 Simulator,” SIMUTools 2009 Conference, March 2009.

## 29.1 Scope of the model

From a MAC perspective, there are two basic modes of operation, that of a Subscriber Station (SS) or a Base Station (BS). These are implemented as two subclasses of the base class `ns3::NetDevice`, class `SubscriberStationNetDevice` and class `BaseStationNetDevice`. As is typical in *ns-3*, there is also a physical layer class `WimaxPhy` and a channel class `WimaxChannel` which serves to hold the references to all of the attached Phy devices. The main physical layer class is the `SimpleOfdmWimaxChannel` class.

Another important aspect of WiMAX is the uplink and downlink scheduler, and there are three primary scheduler types implemented:

- SIMPLE: a simple priority based FCFS scheduler
- RTPS: a real-time polling service (rtPS) scheduler
- MBQOS: a migration-based uplink scheduler

The following additional aspects of the 802.16 specifications, as well as physical layer and channel models, are modelled:

- leverages existing *ns-3* wireless propagation loss and delay models, as well as *ns-3* mobility models

- Point-to-Multipoint (PMP) mode and the WirelessMAN-OFDM PHY layer
- Initial Ranging
- Service Flow Initialization
- Management Connection
- Transport Initialization
- UGS, rtPS, nrtPS, and BE connections

The following aspects are not presently modelled but would be good topics for future extensions:

- OFDMA PHY layer
- Link adaptation
- Mesh topologies
- ARQ
- ertPS connection
- packet header suppression

## 29.2 Using the Wimax models

The main way that users who write simulation scripts will typically interact with the Wimax models is through the helper API and through the publicly visible attributes of the model.

The helper API is defined in `src/wimax/helper/wimax-helper.{cc,h}`.

The example `src/wimax/examples/wimax-simple.cc` contains some basic code that shows how to set up the model::

```
switch (schedType)
{
  case 0:
    scheduler = WimaxHelper::SCHED_TYPE_SIMPLE;
    break;
  case 1:
    scheduler = WimaxHelper::SCHED_TYPE_MBQOS;
    break;
  case 2:
    scheduler = WimaxHelper::SCHED_TYPE_RTPTS;
    break;
  default:
    scheduler = WimaxHelper::SCHED_TYPE_SIMPLE;
}
```

```
NodeContainer ssNodes;
NodeContainer bsNodes;

ssNodes.Create (2);
bsNodes.Create (1);

WimaxHelper wimax;

NetDeviceContainer ssDevs, bsDevs;

ssDevs = wimax.Install (ssNodes,
```

```

        WimaxHelper::DEVICE_TYPE_SUBSCRIBER_STATION,
        WimaxHelper::SIMPLE_PHY_TYPE_OFDM,
        scheduler);
bsDevs = wimax.Install (bsNodes, WimaxHelper::DEVICE_TYPE_BASE_STATION, WimaxHelper::SIMPLE_PHY_TYPE

```

This example shows that there are two subscriber stations and one base station created. The helper method `Install` allows the user to specify the scheduler type, the physical layer type, and the device type.

Different variants of `Install` are available; for instance, the example `src/wimax/examples/wimax-multicast.cc` shows how to specify a non-default channel or propagation model::

```

channel = CreateObject<SimpleOfdmWimaxChannel> ();
channel->SetPropagationModel (SimpleOfdmWimaxChannel::COST231_PROPAGATION);
ssDevs = wimax.Install (ssNodes,
        WimaxHelper::DEVICE_TYPE_SUBSCRIBER_STATION,
        WimaxHelper::SIMPLE_PHY_TYPE_OFDM,
        channel,
        scheduler);
Ptr<WimaxNetDevice> dev = wimax.Install (bsNodes.Get (0),
        WimaxHelper::DEVICE_TYPE_BASE_STATION,
        WimaxHelper::SIMPLE_PHY_TYPE_OFDM,
        channel,
        scheduler);

```

Mobility is also supported in the same way as in Wifi models; see the `src/wimax/examples/wimax-multicast.cc`.

Another important concept in WiMAX is that of a service flow. This is a unidirectional flow of packets with a set of QoS parameters such as traffic priority, rate, scheduling type, etc. The base station is responsible for issuing service flow identifiers and mapping them to WiMAX connections. The following code from `src/wimax/examples/wimax-multicast.cc` shows how this is configured from a helper level::

```

ServiceFlow MulticastServiceFlow = wimax.CreateServiceFlow (ServiceFlow::SF_DIRECTION_DOWN,
        ServiceFlow::SF_TYPE_UGS,
        MulticastClassifier);

bs->GetServiceFlowManager ()->AddMulticastServiceFlow (MulticastServiceFlow, WimaxPhy::MODULATION_T

```

## 29.3 Wimax Attributes

The `WimaxNetDevice` makes heavy use of the *ns-3* attributes subsystem for configuration and default value management. Presently, approximately 60 values are stored in this system.

For instance, class `ns-3::SimpleOfdmWimaxPhy` exports these attributes:

- `NoiseFigure`: Loss (dB) in the Signal-to-Noise-Ratio due to non-idealities in the receiver.
- `TxPower`: Transmission power (dB)
- `G`: The ratio of CP time to useful time
- `txGain`: Transmission gain (dB)
- `RxGain`: Reception gain (dB)
- `Nfft`: FFT size
- `TraceFilePath`: Path to the directory containing SNR to block error rate files

For a full list of attributes in these models, consult the Doxygen page that lists all attributes for *ns-3*.

## 29.4 Wimax Tracing

*ns-3* has a sophisticated tracing infrastructure that allows users to hook into existing trace sources, or to define and export new ones.

Many *ns-3* users use the built-in Pcap or Ascii tracing, and the WimaxHelper has similar APIs::

```
AsciiTraceHelper ascii;
WimaxHelper wimax;
wimax.EnablePcap ("wimax-program", false);
wimax.EnableAsciiAll (ascii.CreateFileStream ("wimax-program.tr"));
```

Unlike other helpers, there is also a special `EnableAsciiForConnection()` method that limits the ascii tracing to a specific device and connection.

These helpers access the low level trace sources that exist in the WiMAX physical layer, net device, and queue models. Like other *ns-3* trace sources, users may hook their own functions to these trace sources if they want to do customized things based on the packet events. See the Doxygen List of trace sources for a complete list of these sources.

## 29.5 Wimax MAC model

The 802.16 model provided in *ns-3* attempts to provide an accurate MAC and PHY level implementation of the 802.16 specification with the Point-to-Multipoint (PMP) mode and the WirelessMAN-OFDM PHY layer. The model is mainly composed of three layers:

- The convergence sublayer (CS)
- The MAC CP Common Part Sublayer (MAC-CPS)
- Physical (PHY) layer

The following figure *WiMAX architecture* shows the relationships of these models.

### 29.5.1 Convergence Sublayer

The Convergence sublayer (CS) provided with this module implements the Packet CS, designed to work with the packet-based protocols at higher layers. The CS is responsible of receiving packet from the higher layer and from peer stations, classifying packets to appropriate connections (or service flows) and processing packets. It keeps a mapping of transport connections to service flows. This enables the MAC CPS identifying the Quality of Service (QoS) parameters associated to a transport connection and ensuring the QoS requirements. The CS currently employs an IP classifier.

### 29.5.2 IP Packet Classifier

An IP packet classifier is used to map incoming packets to appropriate connections based on a set of criteria. The classifier maintains a list of mapping rules which associate an IP flow (src IP address and mask, dst IP address and mask, src port range, dst port range and protocol) to one of the service flows. By analyzing the IP and the TCP/UDP headers the classifier will append the incoming packet (from the upper layer) to the queue of the appropriate WiMAX connection. Class `IpcsClassifier` and class `IpcsClassifierRecord` implement the classifier module for both SS and BS



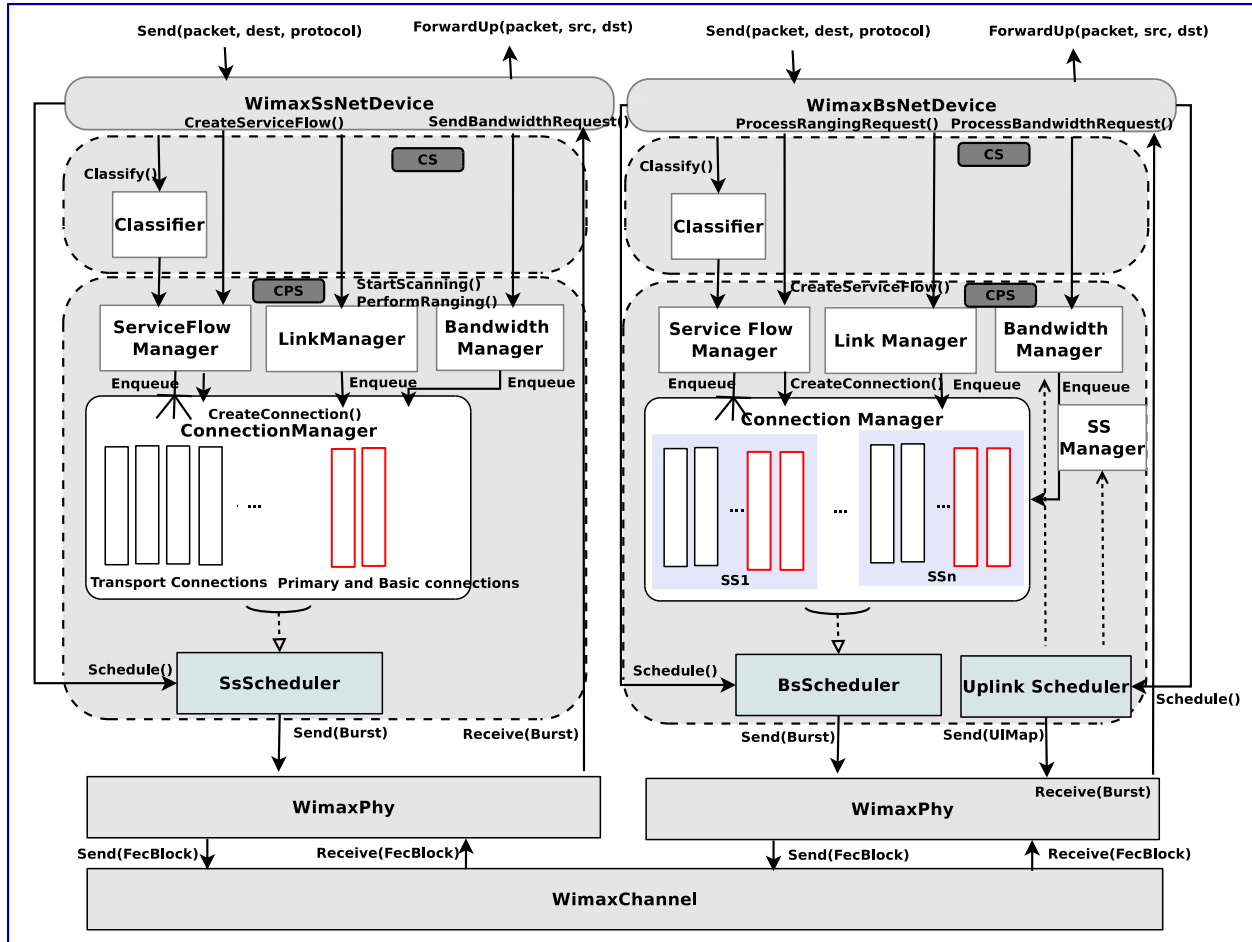

Figure 29.1: WiMAX architecture

### 29.5.3 MAC Common Part Sublayer

The MAC Common Part Sublayer (CPS) is the main sublayer of the IEEE 802.16 MAC and performs the fundamental functions of the MAC. The module implements the Point-Multi-Point (PMP) mode. In PMP mode BS is responsible of managing communication among multiple SSs. The key functionalities of the MAC CPS include framing and addressing, generation of MAC management messages, SS initialization and registration, service flow management, bandwidth management and scheduling services. Class `WimaxNetDevice` represents the MAC layer of a WiMAX network device. This class extends the class `NetDevice` of the *ns-3* API that provides abstraction of a network device. Class `WimaxNetDevice` is further extended by class `BaseStationNetDevice` and class `SubscriberStationNetDevice`, defining MAC layers of BS and SS, respectively. Besides these main classes, the key functions of MAC are distributed to several other classes.

### 29.5.4 Framing and Management Messages

The module implements a frame as a fixed duration of time, i.e., frame boundaries are defined with respect to time. Each frame is further subdivided into downlink (DL) and uplink (UL) subframes. The module implements the Time Division Duplex (TDD) mode where DL and UL operate on same frequency but are separated in time. A number of DL and UL bursts are then allocated in DL and UL subframes, respectively. Since the standard allows sending and receiving bursts of packets in a given DL or UL burst, the unit of transmission at the MAC layer is a packet burst. The module implements a special `PacketBurst` data structure for this purpose. A packet burst is essentially a list of packets. The BS downlink and uplink schedulers, implemented by class `BSScheduler` and class `UplinkScheduler`, are responsible of generating DL and UL subframes, respectively. In the case of DL, the subframe is simulated by transmitting consecutive bursts (instances `PacketBurst`). In case of UL, the subframe is divided, with respect to time, into a number of slots. The bursts transmitted by the SSs in these slots are then aligned to slot boundaries. The frame is divided into integer number of symbols and Physical Slots (PS) which helps in managing bandwidth more effectively. The number of symbols per frame depends on the underlying implementation of the PHY layer. The size of a DL or UL burst is specified in units of symbols.

### 29.5.5 Network Entry and Initialization

The network entry and initialization phase is basically divided into two sub-phases, (1) scanning and synchronization and (2) initial ranging. The entire phase is performed by the `LinkManager` component of SS and BS. Once an SS wants to join the network, it first scans the downlink frequencies to search for a suitable channel. The search is complete as soon as it detects a PHY frame. The next step is to establish synchronization with the BS. Once SS receives a Downlink-MAP (DL-MAP) message the synchronization phase is complete and it remains synchronized as long as it keeps receiving DL-MAP and Downlink Channel Descriptor (DCD) messages. After the synchronization is established, SS waits for a Uplink Channel Descriptor (UCD) message to acquire uplink channel parameters. Once acquired, the first sub-phase of the network entry and initialization is complete. Once synchronization is achieved, the SS waits for a UL-MAP message to locate a special grant, called initial ranging interval, in the UL subframe. This grant is allocated by the BS Uplink Scheduler at regular intervals. Currently this interval is set to 0.5 ms, however the user is enabled to modify its value from the simulation script.

### 29.5.6 Connections and Addressing

All communication at the MAC layer is carried in terms of connections. The standard defines a connection as a unidirectional mapping between the SS and BS's MAC entities for the transmission of traffic. The standard defines two types of connections: management connections for transmitting control messages and transport connections for data transmission. A connection is identified by a 16-bit Connection Identifier (CID). Class `WimaxConnection` and class `Cid` implement the connection and CID, respectively. Note that each connection maintains its own transmission queue where packets to transmit on that connection are queued. The `ConnectionManager` component of BS is responsible of creating and managing connections for all SSs.

The two key management connections defined by the standard, namely the Basic and Primary management connections, are created and allocated to the SS during the ranging process. Basic connection plays an important role throughout the operation of SS also because all (unicast) DL and UL grants are directed towards SS's Basic CID. In addition to management connections, an SS may have one or more transport connections to send data packets. The Connection Manager component of SS manages the connections associated to SS. As defined by the standard, a management connection is bidirectional, i.e., a pair of downlink and uplink connections is represented by the same CID. This feature is implemented in a way that one connection (in DL direction) is created by the BS and upon receiving the CID the SS then creates an identical connection (in UL direction) with the same CID.

### 29.5.7 Scheduling Services

The module supports the four scheduling services defined by the 802.16-2004 standard:

- Unsolicited Grant Service (UGS)
- Real-Time Polling Services (rtPS)
- Non Real-Time Polling Services (nrtPS)
- Best Effort (BE)

These scheduling services behave differently with respect to how they request bandwidth as well as how the it is granted. Each service flow is associated to exactly one scheduling service, and the QoS parameter set associated to a service flow actually defines the scheduling service it belongs to. When a service flow is created the UplinkScheduler calculates necessary parameters such as grant size and grant interval based on QoS parameters associated to it.

### 29.5.8 WiMAX Uplink Scheduler Model

Uplink Scheduler at the BS decides which of the SSs will be assigned uplink allocations based on the QoS parameters associated to a service flow (or scheduling service) and bandwidth requests from the SSs. Uplink scheduler together with Bandwidth Manager implements the complete scheduling service functionality. The standard defines up to four scheduling services (BE, UGS, rtPS, nrtPS) for applications with different types of QoS requirements. The service flows of these scheduling services behave differently with respect to how they request for bandwidth as well as how the bandwidth is granted. The module supports all four scheduling services. Each service flow is associated to exactly one transport connection and one scheduling service. The QoS parameters associated to a service flow actually define the scheduling service it belongs to. Standard QoS parameters for UGS, rtPS, nrtPS and BE services, as specified in Tables 111a to 111d of the 802.16e amendment, are supported. When a service flow is created the uplink scheduler calculates necessary parameters such as grant size and allocation interval based on QoS parameters associated to it. The current WiMAX module provides three different versions of schedulers.

- The first one is a simple priority-based First Come First Serve (FCFS). For the real-time services (UGS and rtPS) the BS then allocates grants/polls on regular basis based on the calculated interval. For the non real-time services (nrtPS and BE) only minimum reserved bandwidth is guaranteed if available after servicing real-time flows. Note that not all of these parameters are utilized by the uplink scheduler. Also note that currently only service flow with fixed-size packet size are supported, as currently set up in simulation scenario with OnOff application of fixed packet size. This scheduler is implemented by class `BSSchedulerSimple` and class `UplinkSchedulerSimple`.
- The second one is similar to first scheduler except by rtPS service flow. All rtPS Connections are able to transmit all packet in the queue according to the available bandwidth. The bandwidth saturation control has been implemented to redistribute the effective available bandwidth to all rtPS that have at least one packet to transmit. The remaining bandwidth is allocated to nrtPS and BE Connections. This scheduler is implemented by class `BSSchedulerRtps` and class `UplinkSchedulerRtps`.
- The third one is a Migration-based Quality of Service uplink scheduler This uplink scheduler uses three queues, the low priority queue, the intermediate queue and the high priority queue. The scheduler serves the requests

in strict priority order from the high priority queue to the low priority queue. The low priority queue stores the bandwidth requests of the BE service flow. The intermediate queue holds bandwidth requests sent by rtPS and by nrtPS connections. rtPS and nrtPS requests can migrate to the high priority queue to guarantee that their QoS requirements are met. Besides the requests migrated from the intermediate queue, the high priority queue stores periodic grants and unicast request opportunities that must be scheduled in the following frame. To guarantee the maximum delay requirement, the BS assigns a deadline to each rtPS bandwidth request in the intermediate queue. The minimum bandwidth requirement of both rtPS and nrtPS connections is guaranteed over a window of duration T. This scheduler is implemented by class `UplinkSchedulerMBQoS`.

### 29.5.9 WiMAX Outbound Schedulers Model

Besides the uplink scheduler these are the outbound schedulers at BS and SS side (`BSScheduler` and `SSScheduler`). The outbound schedulers decide which of the packets from the outbound queues will be transmitted in a given allocation. The outbound scheduler at the BS schedules the downlink traffic, i.e., packets to be transmitted to the SSs in the downlink subframe. Similarly the outbound scheduler at a SS schedules the packet to be transmitted in the uplink allocation assigned to that SS in the uplink subframe. All three schedulers have been implemented to work as FCFS scheduler, as they allocate grants starting from highest priority scheduling service to the lower priority one (UGS> rtPS> nrtPS> BE). The standard does not suggest any scheduling algorithm and instead leaves this decision up to the manufacturers. Of course more sophisticated algorithms can be added later if required.

## 29.6 WimaxChannel and WimaxPhy models

The module implements the Wireless MAN OFDM PHY specifications as the more relevant for implementation as it is the schema chosen by the WiMAX Forum. This specification is designed for non-light-of-sight (NLOS) including fixed and mobile broadband wireless access. The proposed model uses a 256 FFT processor, with 192 data subcarriers. It supports all the seven modulation and coding schemes specified by Wireless MAN-OFDM. It is composed of two parts: the channel model and the physical model.

### 29.7 Channel model

The channel model we propose is implemented by the class `SimpleOFDMWimaxChannel` which extends the class `wimaxchannel`. The channel entity has a private structure named `m_phyList` which handles all the physical devices connected to it. When a physical device sends a packet (FEC Block) to the channel, the channel handles the packet, and then for each physical device connected to it, it calculates the propagation delay, the path loss according to a given propagation model and eventually forwards the packet to the receiver device. The channel class uses the method `GetDistanceFrom()` to calculate the distance between two physical entities according to their 3D coordinates. The delay is computed as  $delay = distance/C$ , where  $C$  is the speed of the light.

### 29.8 Physical model

The physical layer performs two main operations: (i) It receives a burst from a channel and forwards it to the MAC layer, (ii) it receives a burst from the MAC layer and transmits it on the channel. In order to reduce the simulation complexity of the WiMAX physical layer, we have chosen to model offline part of the physical layer. More specifically we have developed an OFDM simulator to generate trace files used by the reception process to evaluate if a FEC block can be correctly decoded or not.

**Transmission Process:** A burst is a set of WiMAX MAC PDUs. At the sending process, a burst is converted into bit-streams and then splitted into smaller FEC blocks which are then sent to the channel with a power equal  $P_{tx}$ .

Reception Process: The reception process includes the following operations:

1. Receive a FEC block from the channel.
2. Calculate the noise level.
3. Estimate the signal to noise ratio (SNR) with the following formula.
4. Determine if a FEC block can be correctly decoded.
5. Concatenate received FEC blocks to reconstruct the original burst.
6. Forward the burst to the upper layer.

The developed process to evaluate if a FEC block can be correctly received or not uses pre-generated traces. The trace files are generated by an external OFDM simulator (described later). A class named SNRToBlockErrorRateManager handles a repository containing seven trace files (one for each modulation and coding scheme). A repository is specific for a particular channel model.

A trace file is made of 6 columns. The first column provides the SNR value (1), whereas the other columns give respectively the bit error rate BER (2), the block error rate BlcER(3), the standard deviation on BlcER, and the confidence interval (4 and 5). These trace files are loaded into memory by the SNRToBlockErrorRateManager entity at the beginning of the simulation.

Currently, The first process uses the first and third columns to determine if a FEC block is correctly received. When the physical layer receives a packet with an SNR equal to SNR<sub>rx</sub>, it asks the SNRToBlockErrorRateManager to return the corresponding block error rate BlcER. A random number RAND between 0 and 1 is then generated. If RAND is greater than BlcER, then the block is correctly received, otherwise the block is considered erroneous and is ignored.

The module provides defaults SNR to block error rate traces in default-traces.h. The traces have been generated by an External WiMAX OFDM simulator. The simulator is based on an external mathematics and signal processing library IT++ and includes : a random block generator, a Reed Solomon (RS) coder, a convolutional coder, an interleaver, a 256 FFT-based OFDM modulator, a multi-path channel simulator and an equalizer. The multipath channel is simulated using the TDL\_channel class of the IT++ library.

Users can configure the module to use their own traces generated by another OFDM simulator or ideally by performing experiments in real environment. For this purpose, a path to a repository containing trace files should be provided. If no repository is provided the traces from default-traces.h will be loaded. A valid repository should contain 7 files, one for each modulation and coding scheme.

The names of the files should respect the following format: modulation0.txt for modulation 0, modulation1.txt for modulation 1 and so on... The file format should be as follows:

SNR_value1	BER	Blc_ER	STANDARD_DEVIATION	CONFIDENCE_INTERVAL1	CONFIDENCE_INTERVAL2
SNR_value2	BER	Blc_ER	STANDARD_DEVIATION	CONFIDENCE_INTERVAL1	CONFIDENCE_INTERVAL2
...	...	...	...	...	...
...	...	...	...	...	...



# BIBLIOGRAPHY

- [Balanis] C.A. Balanis, "Antenna Theory - Analysis and Design", Wiley, 2nd Ed.
- [Chunjian] Li Chunjian, "Efficient Antenna Patterns for Three-Sector WCDMA Systems", Master of Science Thesis, Chalmers University of Technology, Göteborg, Sweden, 2003
- [Calcev] George Calcev and Matt Dillon, "Antenna Tilt Control in CDMA Networks", in Proc. of the 2nd Annual International Wireless Internet Conference (WICON), 2006
- [R4-092042a] 3GPP TSG RAN WG4 (Radio) Meeting #51, R4-092042, Simulation assumptions and parameters for FDD HeNB RF requirements.
- [rfc3561] RFC 3561 *Ad hoc On-Demand Distance Vector (AODV) Routing*
- [turkmani] Turkmani A.M.D., J.D. Parson and D.G. Lewis, "Radio propagation into buildings at 441, 900 and 1400 MHz", in Proc. of 4th Int. Conference on Land Mobile Radio, 1987.
- [TS25814] 3GPP TS 25.814 "Physical layer aspect for evolved Universal Terrestrial Radio Access"
- [TS36101] 3GPP TS 36.101 "E-UTRA User Equipment (UE) radio transmission and reception"
- [TS36104] 3GPP TS 36.104 "E-UTRA Base Station (BS) radio transmission and reception"
- [TS36211] 3GPP TS 36.211 "E-UTRA Physical Channels and Modulation"
- [TS36212] 3GPP TS 36.212 "E-UTRA Multiplexing and channel coding"
- [TS36213] 3GPP TS 36.213 "E-UTRA Physical layer procedures"
- [TS36321] 3GPP TS 36.321 "E-UTRA Medium Access Control (MAC) protocol specification"
- [TS36322] 3GPP TS 36.322 "E-UTRA Radio Link Control (RLC) protocol specification"
- [TS36323] 3GPP TS 36.323 "E-UTRA Packet Data Convergence Protocol (PDCP) specification"
- [R1-081483] 3GPP R1-081483 *Conveying MCS and TB size via PDCCH*
- [R4-092042] 3GPP R4-092042 "Simulation assumptions and parameters for FDD HeNB RF requirements"
- [TR36814] 3GPP TR 36.814 "E-UTRA Further advancements for E-UTRA physical layer aspects"
- [FFAPI] *FemtoForum LTE MAC Scheduler Interface Specification v1.11*
- [ns3tutorial] *The ns-3 Tutorial*
- [ns3manual] *The ns-3 Manual*
- [Sesia2009] S. Sesia, I. Toufik and M. Baker, "LTE - The UMTS Long Term Evolution - from theory to practice", Wiley, 2009

- [Baldo2009] N. Baldo and M. Miozzo, "Spectrum-aware Channel and PHY layer modeling for ns3", Proceedings of ICST NSTools 2009, Pisa, Italy.
- [Piro2010] Giuseppe Piro, Luigi Alfredo Grieco, Gennaro Boggia, and Pietro Camarda, "A Two-level Scheduling Algorithm for QoS Support in the Downlink of LTE Cellular Networks", Proc. of European Wireless, EW2010, Lucca, Italy, Apr., 2010
- [Holtzman2000] J.M. Holtzman, "CDMA forward link waterfilling power control", in Proc. of IEEE VTC Spring, 2000.
- [Piro2011] G. Piro, N. Baldo, M. Miozzo, "An LTE module for the ns-3 network simulator", in Proc. of Wns3 2011 (in conjunction with SimuTOOLS 2011), March 2011, Barcelona (Spain)
- [Seo2004] H. Seo, B. G. Lee. "A proportional-fair power allocation scheme for fair and efficient multiuser OFDM systems", in Proc. of IEEE GLOBECOM, December 2004. Dallas (USA)
- [Ofcom2600MHz] Ofcom, "Consultation on assessment of future mobile competition and proposals for the award of 800 MHz and 2.6 GHz spectrum and related issues", March 2011
- [RealWireless] RealWireless, "Low-power shared access to spectrum for mobile broadband, Final Report, Ofcom Project MC/073, 18th March 2011
- [PaduaPEM] <http://mailman.isi.edu/pipermail/ns-developers/2011-November/009559.html>
- [ViennaLteSim] The Vienna LTE Simulators <http://www.nt.tuwien.ac.at/about-us/staff/josep-colom-ikuno/lte-simulators/>
- [LozanoCost] Joan Olmos, Silvia Ruiz, Mario García-Lozano and David Martín-Sacristán, "Link Abstraction Models Based on Mutual Information for LTE Downlink", COST 2100 TD(10)11052 Report
- [wimaxEmd] WiMAX Forum White Paper, WiMAX System Evaluation Methodology, July 2008.
- [mathworks] Matlab R2011b Documentation Communications System Toolbox, [Methodology for Simulating Multipath Fading Channels](#)
- [CatreuxMIMO] 19. Catreux, L.J. Greenstein, V. Erceg, "Some results and insights on the performance gains of MIMO systems," Selected Areas in Communications, IEEE Journal on , vol.21, no.5, pp. 839- 847, June 2003
- [Ikuno2010] J.C. Ikuno, M. Wrulich, M. Rupp, "System Level Simulation of LTE Networks," Vehicular Technology Conference (VTC 2010-Spring), 2010 IEEE 71st , vol., no., pp.1-5, 16-19 May 2010
- [rfc3626] RFC 3626 *Optimized Link State Routing*
- [hata] M.Hata, "Empirical formula for propagation loss in land mobile radio services", IEEE Trans. on Vehicular Technology, vol. 29, pp. 317-325, 1980
- [cost231] "Digital Mobile Radio: COST 231 View on the Evolution Towards 3rd Generation Systems", Commission of the European Communities, L-2920, Luxembourg, 1989
- [walfisch] J.Walfisch and H.L. Bertoni, "A Theoretical model of UHF propagation in urban environments," in IEEE Trans. Antennas Propagat., vol.36, 1988, pp.1788- 1796
- [ikegami] F.Ikegami, T.Takeuchi, and S.Yoshida, "Theoretical prediction of mean field strength for Urban Mobile Radio", in IEEE Trans. Antennas Propagat., Vol.39, No.3, 1991
- [kun2600mhz] Sun Kun, Wang Ping, Li Yingze, "Path loss models for suburban scenario at 2.3GHz, 2.6GHz and 3.5GHz", in Proc. of the 8th International Symposium on Antennas, Propagation and EM Theory (ISAPE), Kunming, China, Nov 2008.
- [ieee80211] IEEE Std 802.11-2007 *Wireless LAN Medium Access Control (MAC) and Physical Layer (PHY) Specifications*
- [pei80211b] G. Pei and Tom Henderson, [Validation of ns-3 802.11b PHY model](#)



[pei80211ofdm] G. Pei and Tom Henderson, [Validation of OFDM error rate model in ns-3](#)

[lacage2006yans] M. Lacage and T. Henderson, [Yet another Network Simulator](#)

[ji2004sslswn] Z. Ji, J. Zhou, M. Takai and R. Bagrodia, *Scalable simulation of large-scale wireless networks with bounded inaccuracies*, in Proc. of the Seventh ACM Symposium on Modeling, Analysis and Simulation of Wireless and Mobile Systems, October 2004.