



Simulating LTE and Wi-Fi Coexistence in Unlicensed Spectrum with ns-3

Lorenza Giupponi, Biljana
Bojovic

Tom Henderson
University of Washington

Additional contributors:
Marco Miozzo, Nicola
Baldo
CTTC

Additional contributors:
Sumit Roy, Hossein
Savafi, Ben Cizdziel,
Farah Nadeem
University of Washington

May, 2016

- The use of [unlicensed spectrum](#) for future LTE systems raises concerns about its impact on co-located Wi-Fi.
- Licensed bands are augmented by carriers located in unlicensed bands.
- Based on [Carrier Aggregation](#), Secondary cells (SCell) can carry data transmissions in unlicensed bands, with assistance from a Primary Cell (PCell).
- We report here on recent extensions of the [ns-3 simulator](#) to model such coexistence.
- ns-3 is a system simulator allowing for [full-protocol](#) stack evaluation of coexistence.
- ns-3 is the only [freely available](#) simulator for coexistence studies known to the authors.

- LTE physical channels are designed on the basis of **uninterrupted** and **synchronous** operation.
- LTE is designed to deal with reuse factor 1, to efficiently exploit licensed spectrum. It relies on interference cancellation and mitigation techniques.
- Existing systems in unlicensed spectrum operate in **decentralized**, **asynchronous** manner.
- Wi-Fi exploits interference avoidance principles
- Critical design issue: LTE has to coexist with other technologies, in a “**fair**” and “**friendly**” basis.
- 3GPP has defined **fairness** in technical report TR36.889 as follows:

Fairness is the capability of an LAA network not to impact Wi-Fi networks active on a carrier more than an additional Wi-Fi network operating on the same carrier, in terms of both throughput and latency.

- Different regional regulatory requirements for transmission in unlicensed bands further complicate the design.

- In some markets such as Europe and Japan, a “sense and avoid” (or "listen before talk") approach is mandated before transmitting.
- Transmitters must first detect whether the channel is free before initiating a transmission.
- This requires modifications to the LTE air interface.
- Other markets, such as North America, Korea and China, such requirements do not exist.
- To meet ETSI’s requirements, **3GPP** is producing a standardized version of LTE in unlicensed: **Licensed Assisted Access (LAA)**
- **LTE-U Forum** is specifying and developing a proprietary solution for access in unlicensed bands without Listen Before Talk (LBT) requirements

LTE in unlicensed (LTE-U)

- LTE-U Forum is an industry consortium specifying a solution referred to as **LTE-U**
- This is based on LTE **duty-cycling** its transmission, i.e. alternating ON and OFF periods, by estimating the most appropriate channel share that it should occupy.
- The most representative algorithm for LTE-U to share the channel is **Qualcomm's CSAT**.
- Qualcomm has provided demonstrations at MWC16, and there are already products (e.g. Spidercloud, Samsung small cells) with such Qualcomm chips.
- Verizon trials with these products have been announced.

- 3GPP is standardizing a solution that can be deployed under all regulatory requirements.
- It is a system to be deployed as a [Supplemental Downlink \(SDL\)](#) in 5 GHz band.
- A Study Item has been recently finalized and has produced a TR 36.889, where a summary of simulation results has been presented and discussed.
- Release 14 is now focusing on [eLAA](#), which includes UL.
- Other initiatives, [MuLTEfire](#), rely on Rel. 13 and 14 to provide a complete solution not anchored to the licensed band



Ns-3 extensions to study coexistence



- To support coexistence study evaluations, [Wi-Fi Alliance](#) funded simulation extensions of ns-3.
- The ns-3 Wi-Fi models have been developed over time by various authors, usually by directly referencing IEEE standards.
- They started with IEEE 802.11a and later many aspects of IEEE 802.11b/g/p/e/n/ac have been included.
- We made many model enhancements to allow for Wi-Fi module and LTE module to inter-operate and interfere with one another.
- ns-3 Wi-Fi physical (PHY) model had to be updated to the multi-technology Spectrum framework in ns-3 (allowing Wi-Fi signals to be received on LTE devices, and vice versa).
- This has resulted in a new *SpectrumWiFiPhy* class that reuses the existing interference manager and error rate models, but allows foreign signals (like LTE) to be added to the noise on the channel.



Model enhancements in Wi-Fi



- Wi-Fi Clear Channel Access was enhanced to sense for non-Wi-Fi signals and to support CCA-ED (-62 dBm) and CCA-PD (-82 dBm) thresholds.
- Wi-Fi preamble detection (PD) based on AWGN channel model, and also TGn fading Channel Model D
- Wi-Fi RSS-based AP selection and roaming
- Wi-Fi MIMO approximations to support 2x2 DL, 1x2 DL on AWGN and TGn Model D

- LTE interference model relies on the simplifying assumption that all interfering signals are LTE and are synchronized at subframe level.
- LTE interference model has been enhanced to handle interference by signals of any type.
- This relies on ns-3 Spectrum framework.
- The reception of LTE signals is evaluated by chunks, where each chunk is identified by a constant power spectral density.

- An initial test scenario, useful for testing basic model operation in a small scale setting, grew into TR36.889-like indoor and outdoor scenarios
- In the initial test scenario depicted below, d_1 and d_2 can vary and operator A and B can be either LTE or Wi-Fi

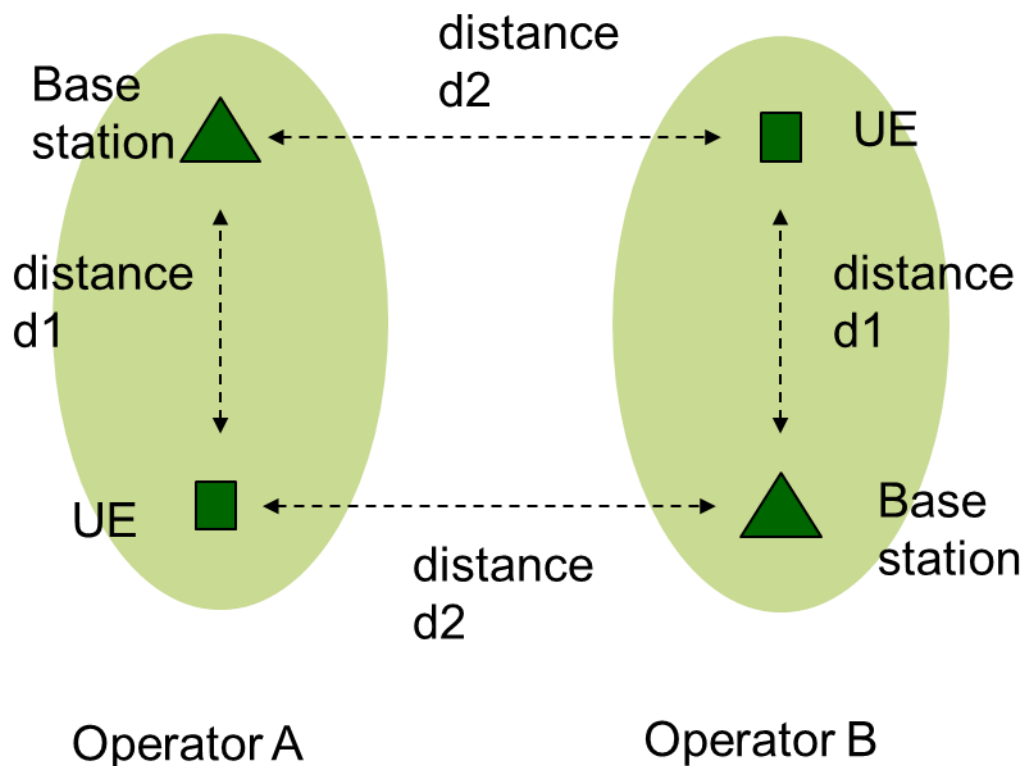

Unlicensed channel model	3GPP TR 36.889	ns-3 implementation
Network Layout	Indoor scenario	Indoor scenario
System bandwidth	20 MHz	20 MHz
Carrier frequency	5 GHz	5 GHz (channel 36, tunable)
Number of carriers	1, 4 (to be shared between two operators) 1 for evaluations with DL+UL Wi-Fi coexisting with DL-only LAA	1 for evaluations with DL+UL Wi-Fi coexisting with DL-only LAA
Total Base Station (BS) transmission power	18/24 dBm	18/24 dBm Simulations herein consider 18 dBm
Total User equipment (UE) transmission power	18 dBm for unlicensed spectrum	18 dBm
Distance dependent path loss, shadowing and fading	ITU InH	802.11ax indoor model
Antenna pattern	2D Omni-directional	2D Omni-directional
Antenna height	6 m	6 m (LAA, not modelled for Wi-Fi)
UE antenna height	1.5 m	1.5 m (LAA, not modelled for Wi-Fi)
Antenna gain	5 dBi	5 dBi
UE antenna gain	0 dBi	0 dBi
Number of UEs	10 UEs per unlicensed band carrier per operator for DL-only 10 UEs per unlicensed band carrier per operator for DL-only for four unlicensed carriers. 20 UEs per unlicensed band carrier per operator for DL+UL for single unlicensed carrier. 20 UEs per unlicensed band carrier per operator for DL+UL Wi-Fi coexisting with DL-only LAA	Supports all the configurations in TR 36.889. Simulations herein consider the case of 20 UEs per unlicensed band carrier per operator for DL LAA coexistence evaluations for single unlicensed carrier.
UE Dropping	All UEs should be randomly dropped and be within coverage of the small cell in the unlicensed band.	Randomly dropped and within small cell coverage.
Traffic Model	FTP Model 1 and 3 based on TR 36.814 FTP model file size: 0.5 Mbytes. Optional: VoIP model based on TR36.889	FTP Model 1 as in TR36.814. FTP model file size: 0.5 Mbytes Voice model: DL only
UE noise figure	9 dB	9 dB
Cell selection	For LAA UEs, cell selection is based on RSRP (Reference Signal Received Power). For Wi-Fi stations (STAs), cell selection is based on RSS (Received signal power strength) of WiFi Access Points (APs). RSS threshold is -82 dBm.	RSRP for LAA UEs and RSS for Wi-Fi STAs
Network synchronization	For the same operator, the network can be synchronized. Small cells of different operators are not synchronized.	Small cells are synchronized, different operators are not synchronized.

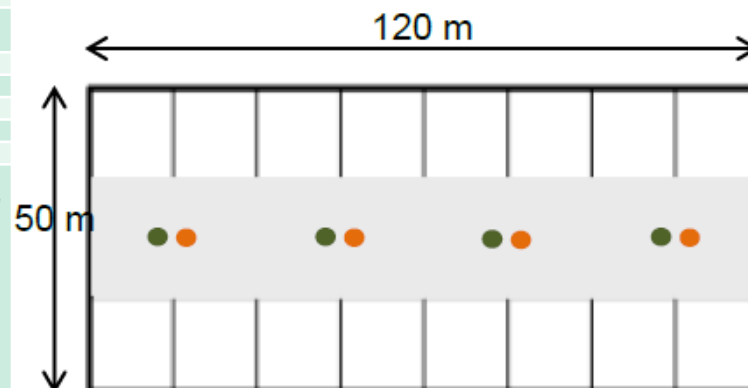

Figure source: 3GPP TR 36.889 V13.0.0 (2015-05)

Outdoor layout: hexagonal macrocell layout. 7 macro sites and 3 cells per site. 1 Cluster per cell. 4 small cells per operator per cluster, uniformly dropped. ITU UMi channel model.

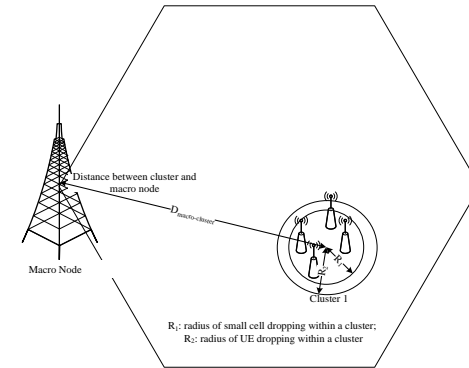
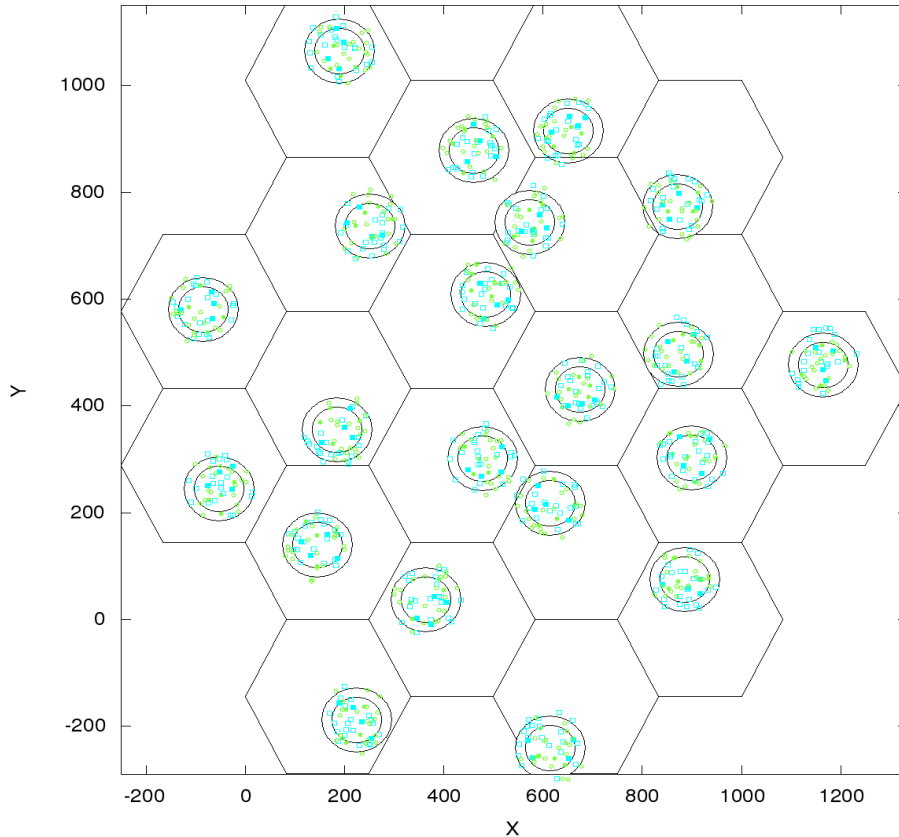

Figure source: 3GPP TR 36.889 V13.0.0 (2015-05)

- The overall offered load is to be the same for both coexisting networks.
- TR36.889 calls for several traffic models.
- We have implemented the [FTP Model 1](#).
 - It simulates file transfers arriving according to a Poisson process with arrival rate λ across the entire operator network.
 - The recommended range for λ is between from 0.5 to 2.5. The file size is 2 Mbytes with 0.5 Mbytes optional in TR 36.814, but TR 36.889 requests the 0.5 Mbytes size.
- We provide a [constant bit rate UDP flow](#) option, with varying bit rates up to saturation.
- We also support a [Voice application](#) based on TR36.889
 - 100% downlink activity
 - Voice replaces rather than adds to a UE FTP flow
 - Voice added on only the operator B network
 - 50% DL and 50% UL traffic (talk spurts of 5 sec)

- Performance metrics are described in TR 36.889.
- The main performance metrics are ‘**user perceived throughput**’ and ‘**latency**’, plotted as CDFs, for a given scenario.
- In ns-3, we are calculating these by using the built-in FlowMonitor tool that tracks per-flow statistics including throughput and latency, and we then post-process these results to obtain CDFs.
- In case of **voice**, Packets are marked for Expedited Forwarding and handled by AC_VO category.
 - Latency threshold of 50 ms, and voice outage declared based on < 98% packets arriving within latency bound.
 - **Per-packet latency** CDF plots

- Throughput and latency statistics tell how well the network performs to users, but do an inadequate job of explaining why.
- We heavily instrumented the simulator to log and classify:
 - All PHY layer transmissions
 - Backoff values
 - Evolution of contention windows
 - HARQ feedback logs
 - Wi-Fi retransmissions
 - TCP retransmission events

- 20 MHz 802.11n tuned to channel 36 (5.18 GHz)
- AWGN-based or TGn channel model D error models.
- Energy detection (ED)-based CCA for detection of other RAT, Preamble detection (PD)-based CCA for Wi-Fi frame detection at the threshold of signal detection, around -88 dBm (i.e. more sensitive than the -82 dBm threshold).
- WiFi's CCA ED (to LAA signals) defaults to -62 dBm.
- The current model is limited to 802.11n 2x2 MIMO (supported by a MIMO abstraction model) and an MCS 15 maximum rate, rather than 802.11ac.
- We do not support transmission beamforming (TxBF).
- An adaptive but idealized, feedback-based Wi-Fi rate control is used; rate control adjustments are made immediately upon feedback from the peer and not due to a probing algorithm such as Minstrel.

Block diagram of coexistence simulator

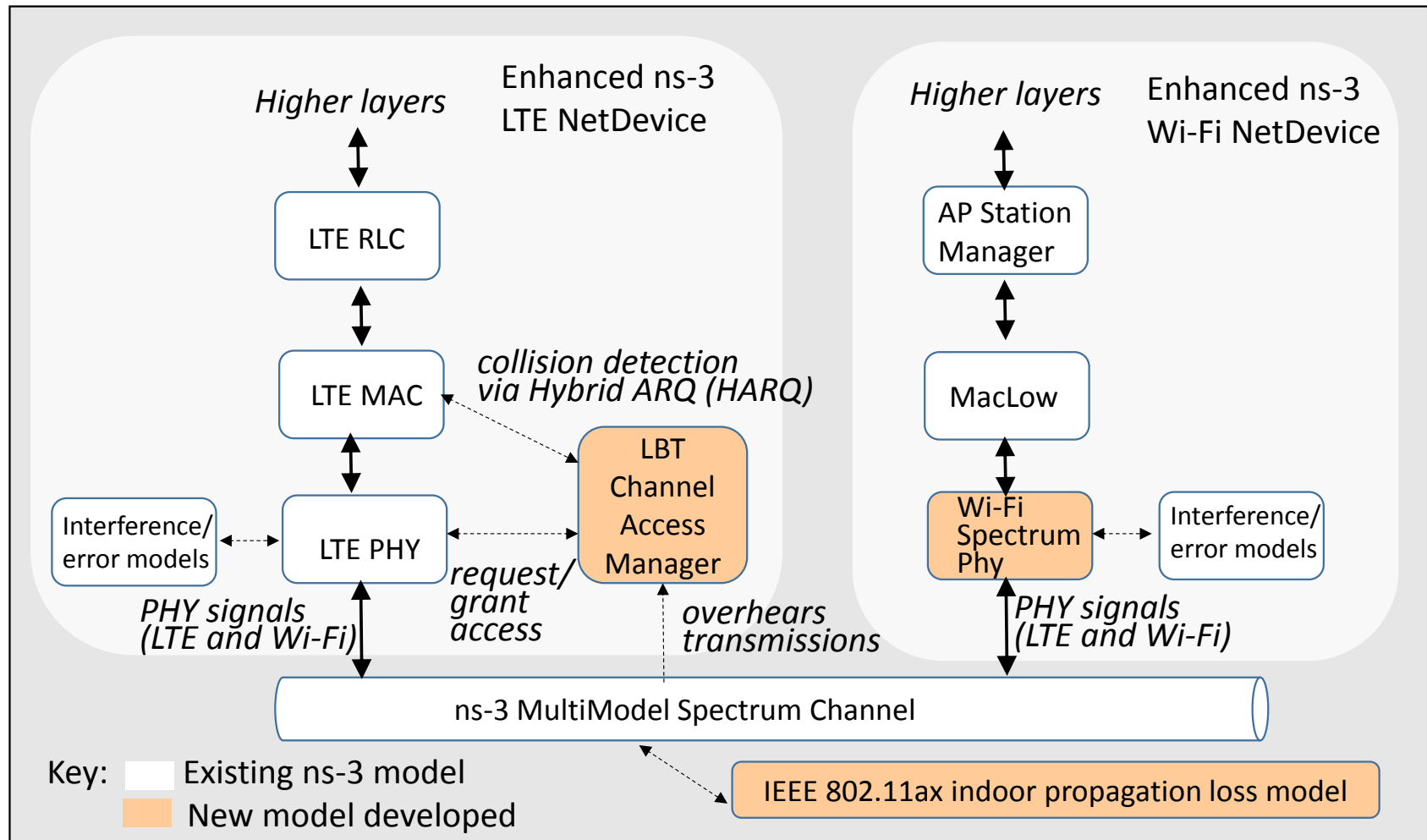

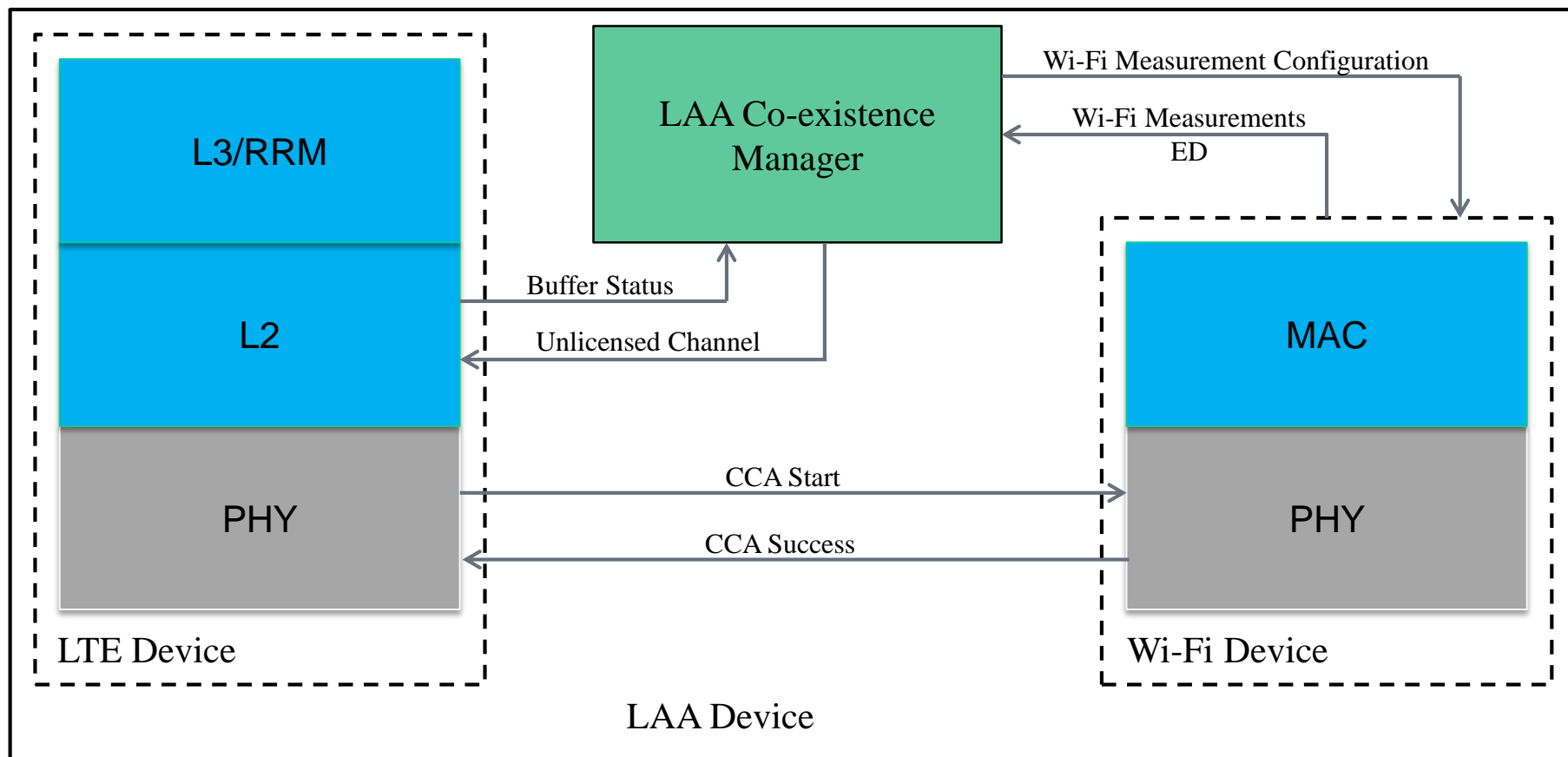

- LAA uses an exponential backoff according to the Category 4 design
- The update of the contention window is implemented following a HARQ feedback based approach, as suggested in [R1-156332].
- LAA Energy Detection threshold (ED) is separately tunable (-72 dBm default, based on latest agreements).
- LAA model defaults to a fixed defer time of 43 us.
- LAA CCA slot time 9 us.
- CWmin=15, CWmax=63 (based on latest agreements, configurable upward to 1023).
- LAA model defaults to 8 ms TXOP, based on latest agreements. It is configurable upward to 20 ms.
- Data transfer starts at subframe boundary. We implement reservation signals to occupy the channel and force other nodes to defer, while we are not occupying the channel with data.



Wi-Fi CCA



- Wi-Fi implements a Distributed Coordination Function (DCF) or Enhanced Distributed Coordination Access (EDCA)
- Resolves contention among competing nodes by implementing a random backoff with exponentially increasing maximum contention window.

- Different LBT categories have been evaluated, and finally the most similar to Wi-Fi was selected.
- In LBT, nodes wishing to transmit must observe a clear channel during 43 us deferral period.
- After this the node can transmit immediately if the channel was idle.
- If the medium was busy, an extended CCA is performed till channel is deemed idle.
- The channel is observed during a random number N multiplied by the CCA slot duration of 9 us.
- N is the number of clear slots that need to be observed before transmitting
- N is randomly selected between 1 and q .
- q is the upper bound of the contention window, which varies between 15 and 63
- The contention window size (CWS) is increased upon collision detection and reset upon absence of collision

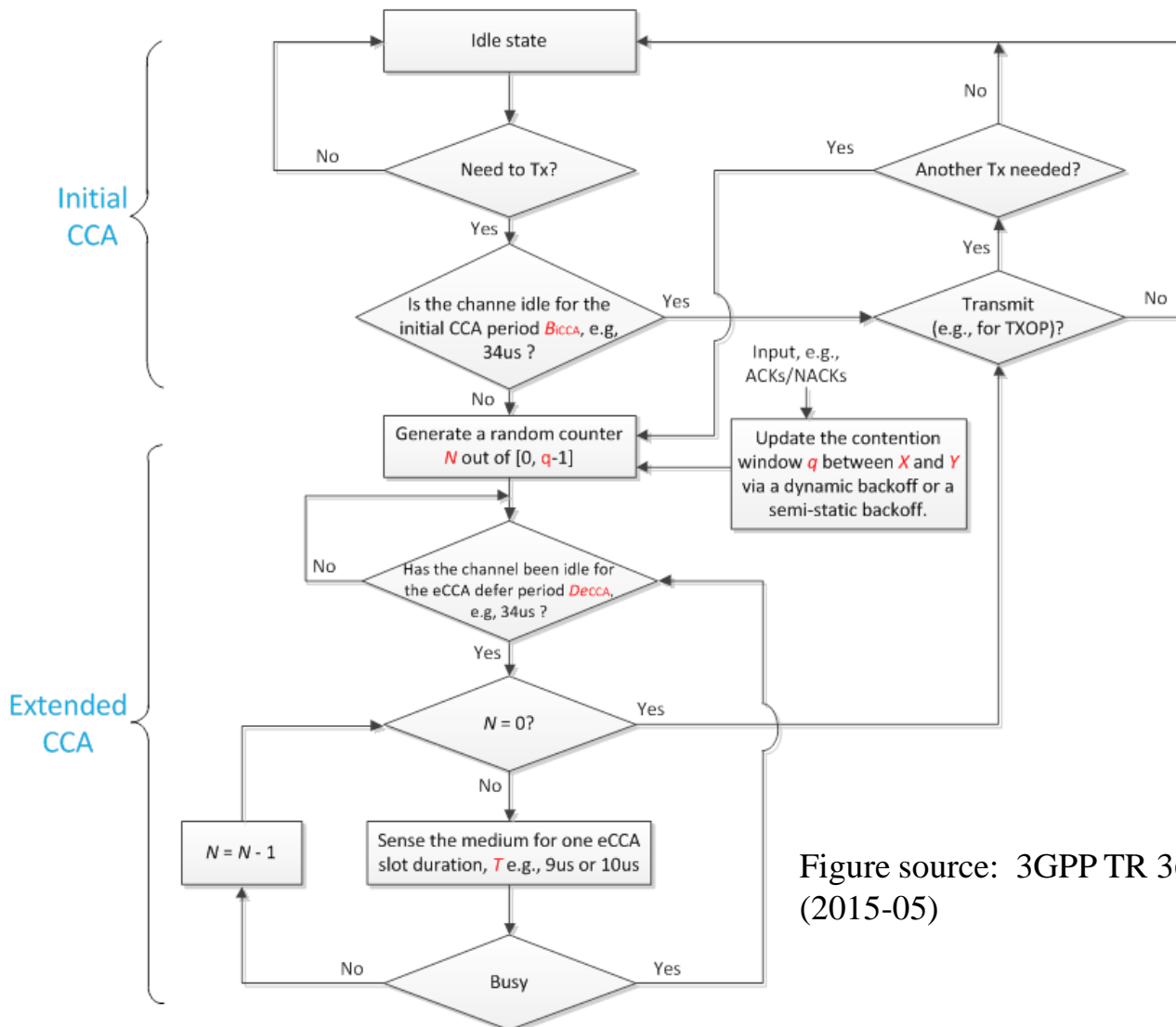

Figure source: 3GPP TR 36.889 V13.0.0 (2015-05)

CWS adjustment based on HARQ-ACKs

- Based on R1-156332
- The CWS is increased if at least Z % of the HARQ-ACK feedback values for a reference subframe set are NACK. Otherwise, the CWS is reset to the minimum value (i.e., 15).
 - Reference subframe set (to be down selected)
 - Alt. 1: the latest DL subframe for which HARQ-ACK feedback is available
 - Alt. 2: the first DL subframe of the latest DL data burst for which HARQ-ACK feedback is available.
 - Alt. 3: all subframes of the latest DL data burst for which HARQ-ACK feedback is available.
 - Z value: Select one out of {10%, 50%, 75%, 80%, 100%}.
 - Z is configurable, and according to latest agreements is set to 80% by default.

- In Wi-Fi each tx burst is a **point-to-point transmission**, so there is only one ACK/NACK for each tx burst.
- In LAA each tx burst is a **point-to-multipoint transmission**, so the way of combining the multiple feedbacks received from the different UEs can impact the update of the CW, and ultimately the channel occupancy.
- The scheduler has an impact.
- In Wi-Fi the feedback is sent after 16 μ s, while in LAA it is sent 7 ms after the transmission. So **update is delayed**.
- HARQ does not necessarily reflect collisions! **It is hard to say if we are really detecting collisions through NACKs**
- The standard LTE transmissions are designed to maintain the BLER to 10%, so there may easily be NACKs without collision (easily solved by HARQ).
- Alternative 2, down-selected in November 2015 3GPP meeting makes that if a collision is detected in a subframe different than the first one, may be ignored

DRS and system information model

- DRS signals have to be sent during the so called DMTC window (6 msec between SF0 and SF5). This occurs with a **configurable periodicity $T=40/80/160$ msec**.
- If data is scheduled during DMTC window, DRS is embedded in data transmission. Otherwise it is sent alone, without data.
- DRS transmission without data is **subject to LBT**. It should be subject to a **priority LBT** with a fixed defer period of only 25 us, but we consider a normal LBT, as for data.
- When DRS is sent without data, we model it with 14 symbols (1 msec).
- In addition, PSS/SSS are sent in every subframe 0 and 5 that data is scheduled, and CRC is scheduled in every subframe that data is scheduled.
- System information is channeled through **primary cell**.

- We evaluate performances of the above mentioned traffic models over both **UDP** and **TCP** transport protocols.
- For TCP, we default to **TCP NewReno**.
- Ns-3 offers multiple options.
- As for the LAA link layer, we consider UDP over RLC-UM and TCP over both **RLC-AM** and **RLC-UM**.

MAC-PHY DL/UL timings

SF	0	1	2	3	4	5	6	7	8	9	0
MAC	generate DCI / PDU								Process UL HARQ		
PHY		code PDCCH PDSCH						Decode PUSCH PUCCH		PHICH coding	
AIR											
UE PHY				Decode PDCCH PDSCH		code PUCCH PUSCH					
UE MAC					generate PUCCH PUSCH						

- The scheduler/MAC works 2 subframes in advance wrt when the data actually occupies the channel.
- In UL we use synchronous HARQ, and in DL asynchronous HARQ, according to standard.
- UE MAC responds in UL SF #n+4 to events of eNB MAC happened in DL SF #n
- eNB MAC responds in DL SF #n+4 to events of UE MAC happened in UL SF #n

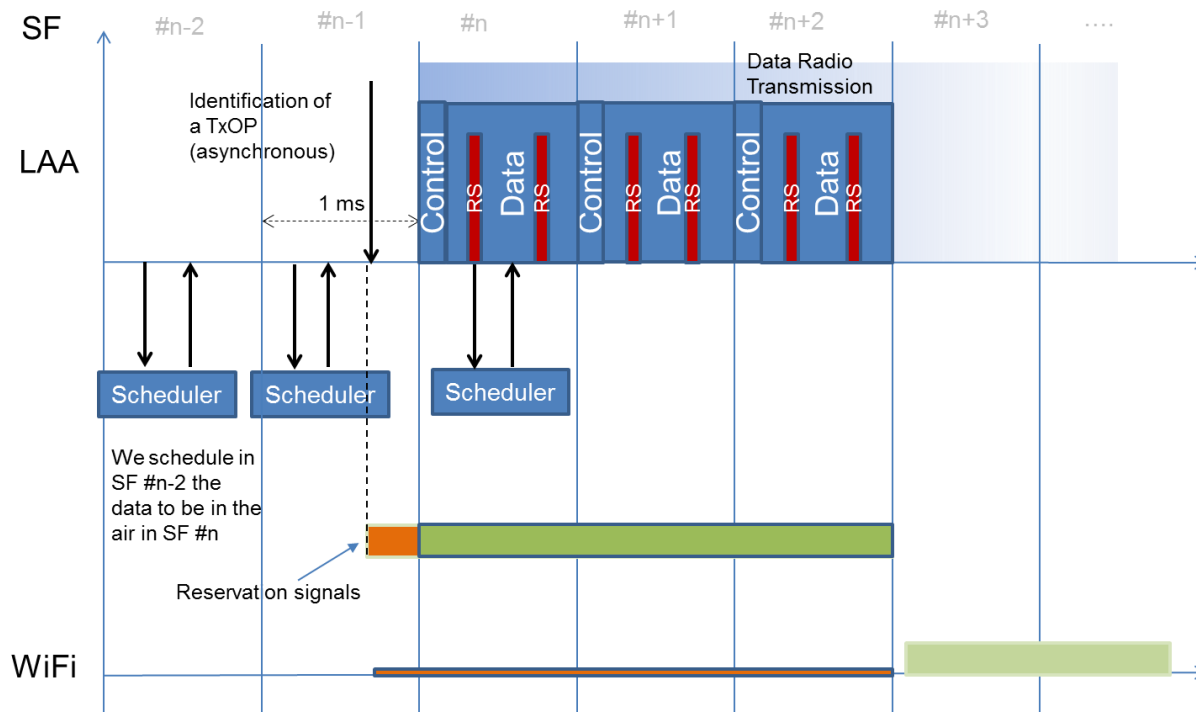

- Partial subframes are not supported
- Differently from some studies in 3GPP (e.g. QCOM, BCOM), where the length of reservation is a random variable uniformly distributed between 0 and 0.5 ms, here it is distributed between 0 and 1 ms.
- Channel access request deferred until data is already scheduled and ready for imminent transmission on next subframe.

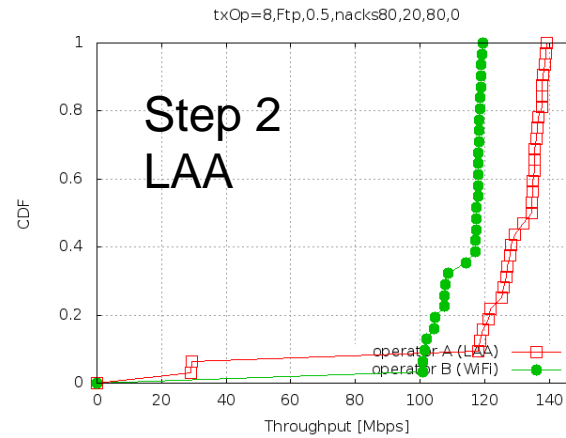
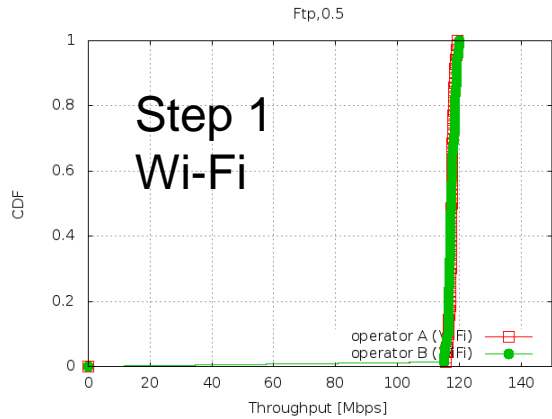

Throughput

$\lambda = 0,5$

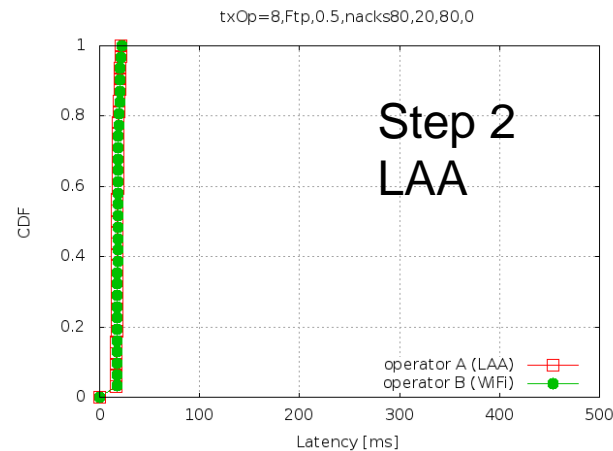
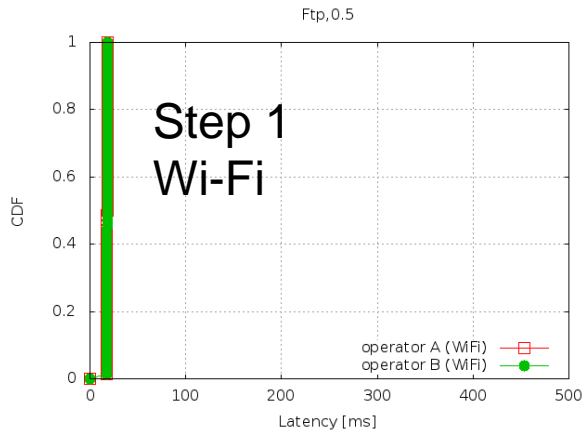

Latency

$\lambda = 0,5$

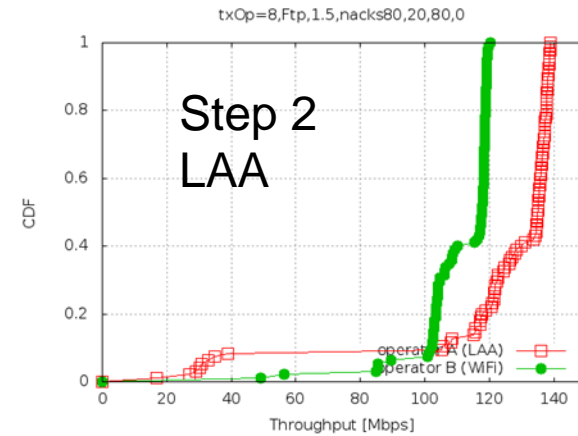
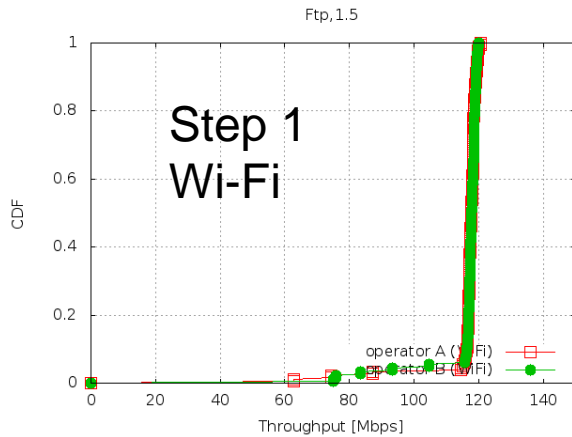

Throughput

$\lambda = 1,5$

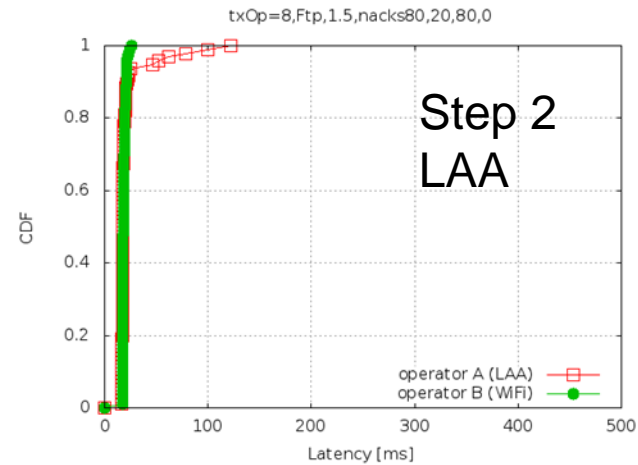
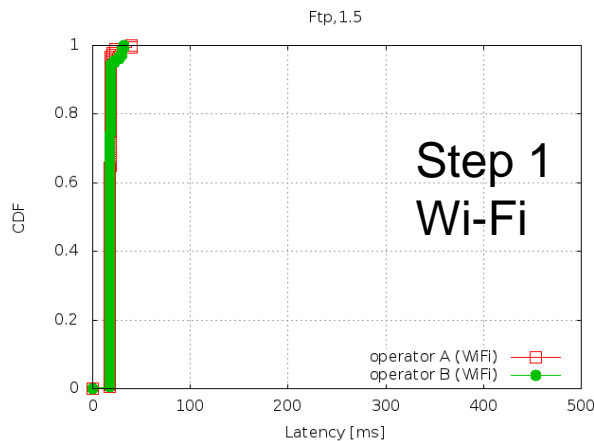

Latency

$\lambda = 1,5$

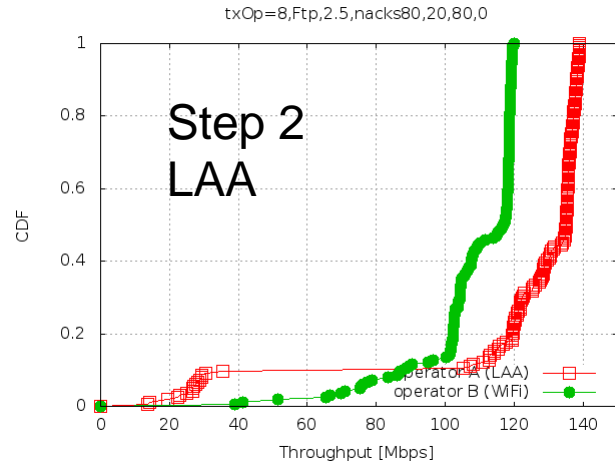
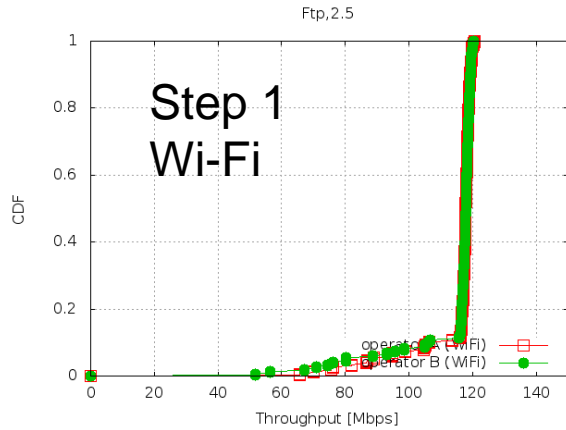

Throughput

$\lambda = 2,5$

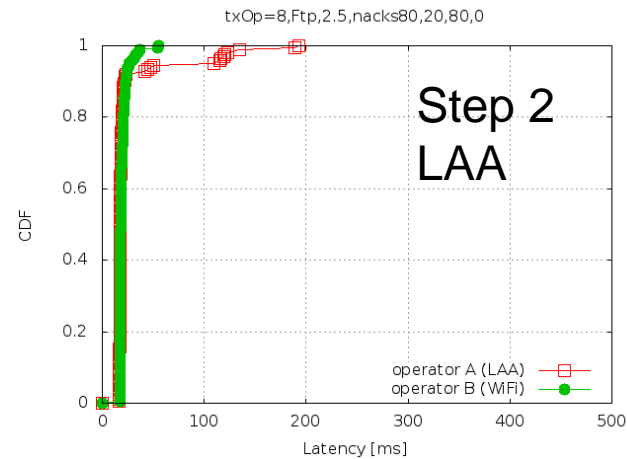
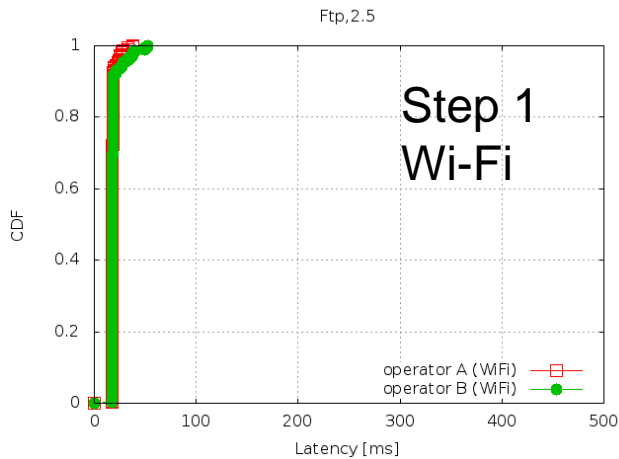

Latency

$\lambda = 2,5$

FTP over UDP and RLC-UM for different λ

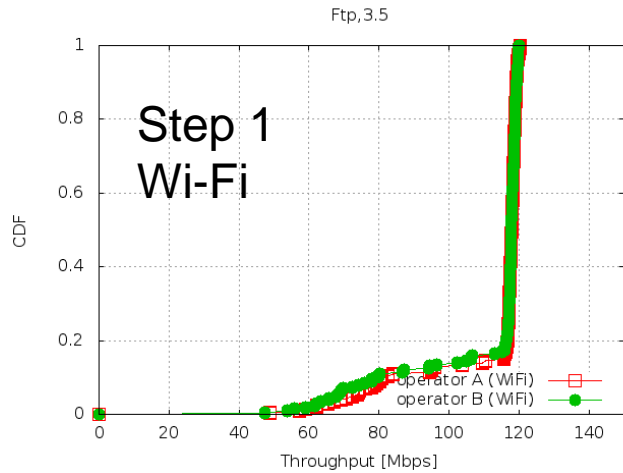

Throughput

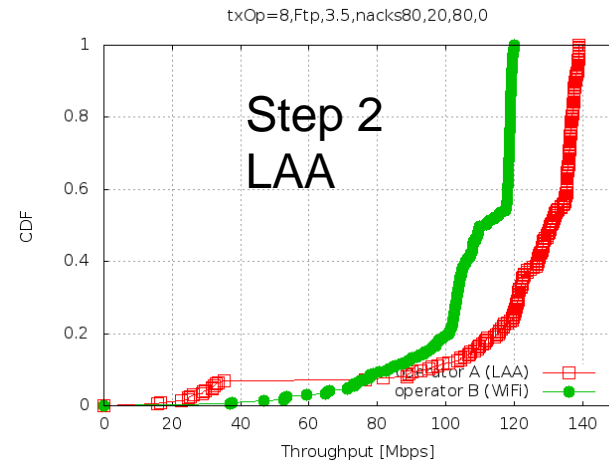

$\lambda = 3,5$

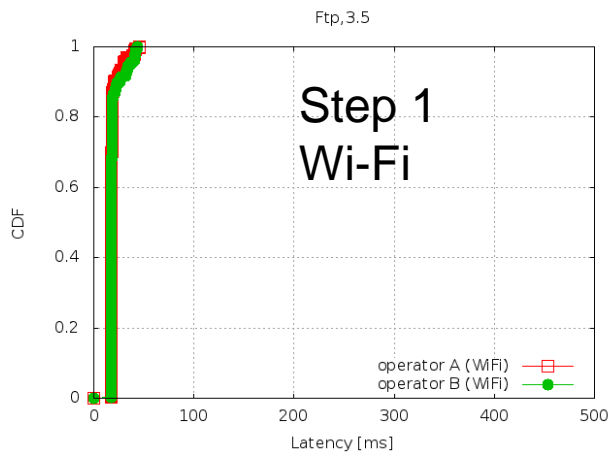

Latency

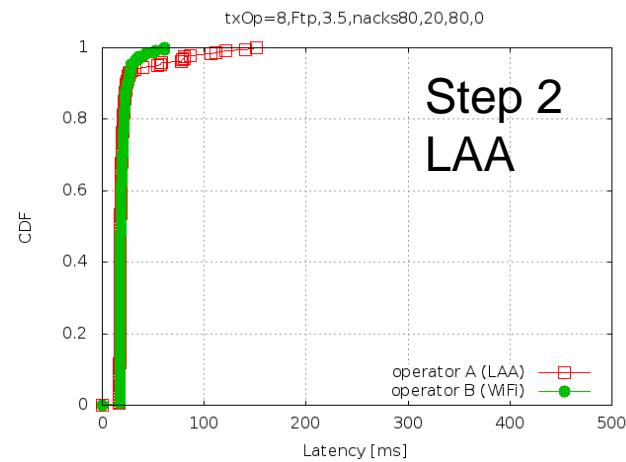

$\lambda = 3,5$

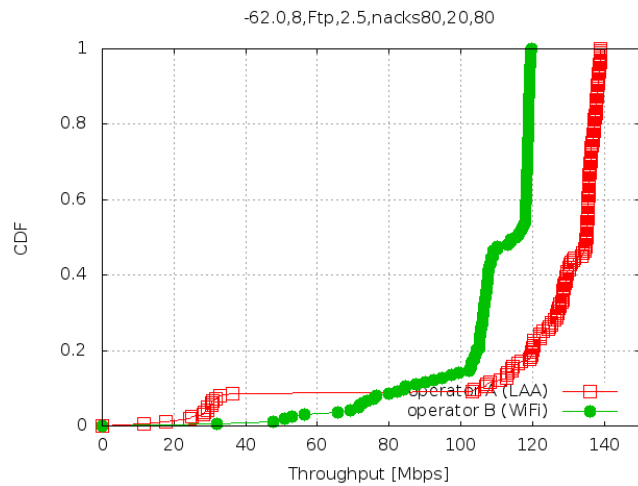

-62 dBm

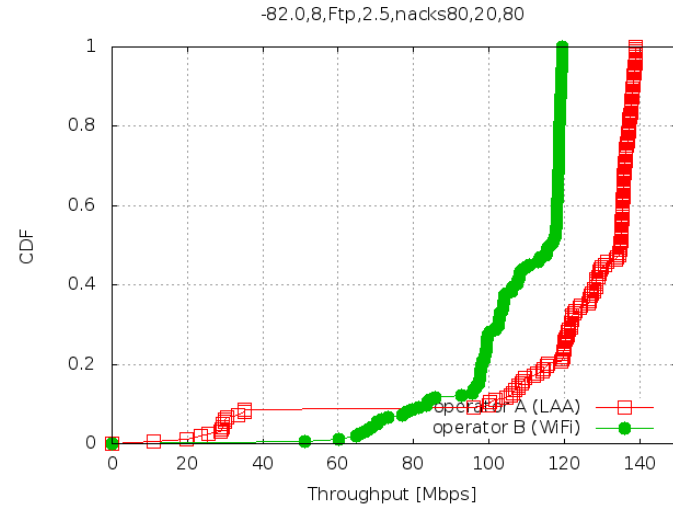

-82 dBm

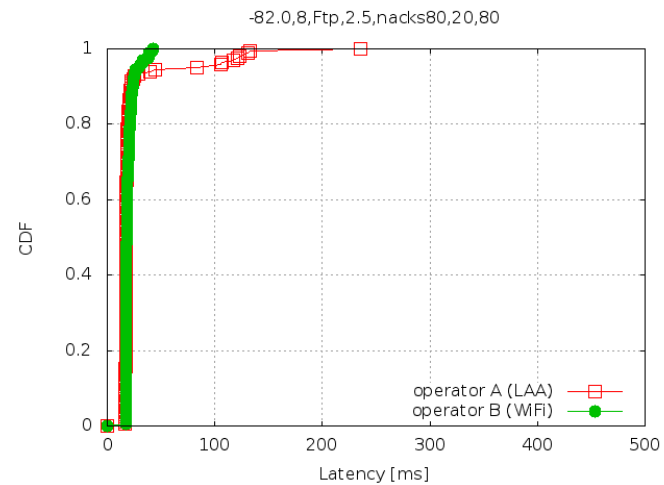
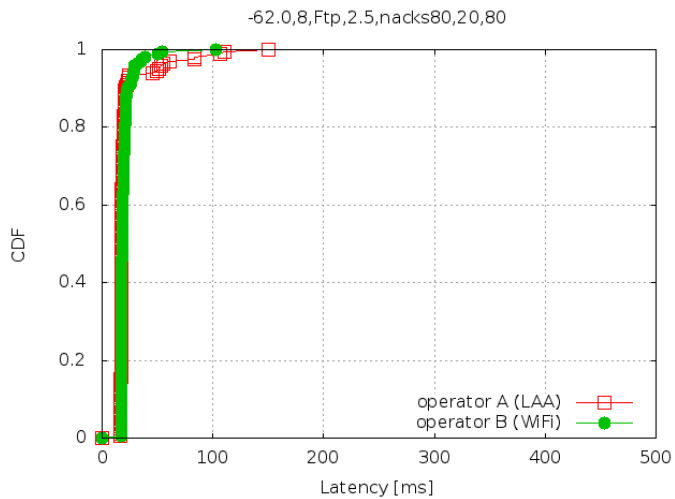

Impact of CTS2self

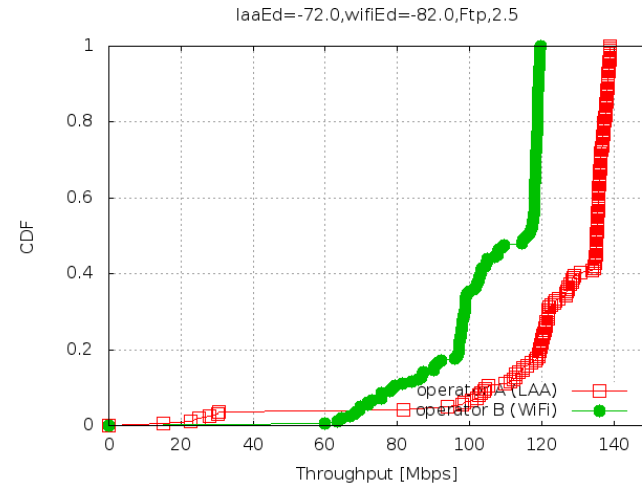
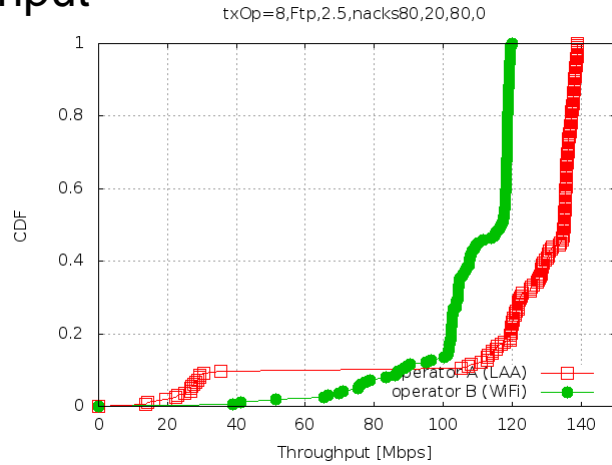

without

with

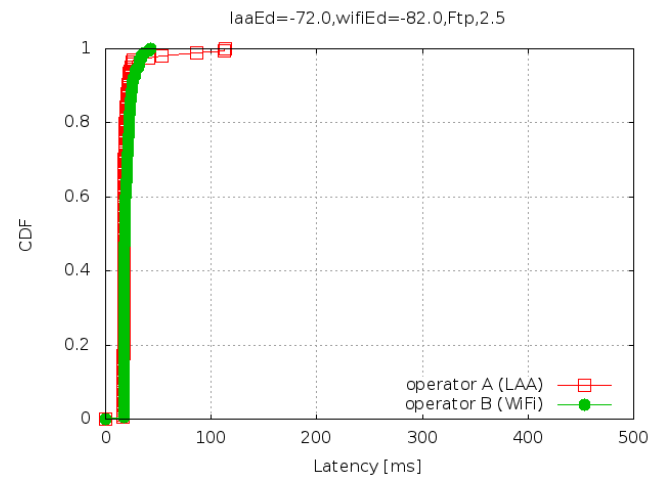
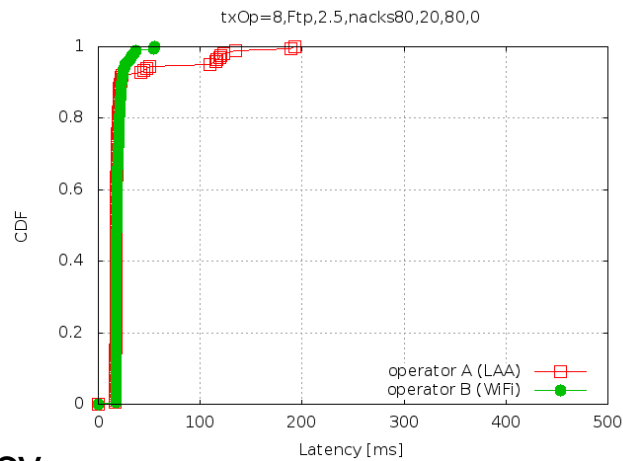

Latency

txOp=8,Ftp,2.5,nacks80,20,40,0

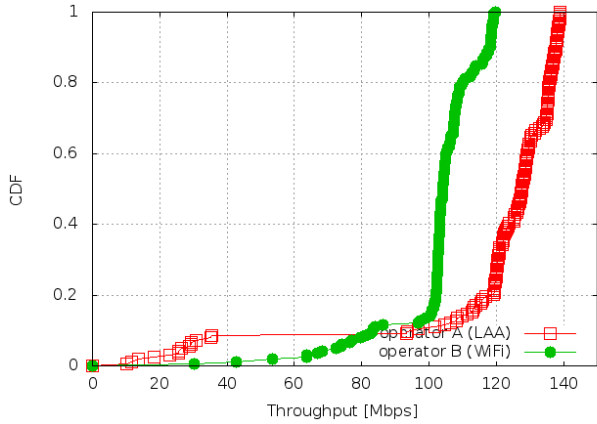

Throughput $T=40$ ms

txOp=8,Ftp,2.5,nacks80,20,80,0

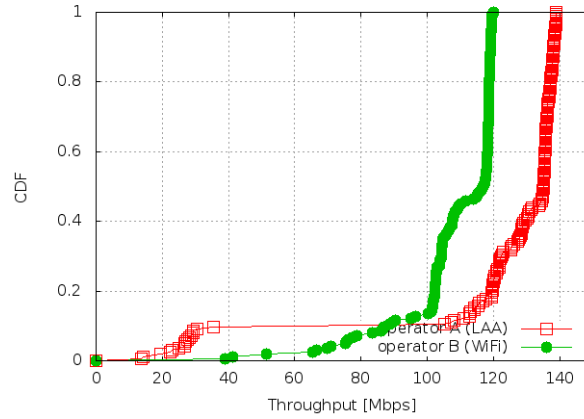

$T=80$ ms

txOp=8,Ftp,2.5,nacks80,20,160,0

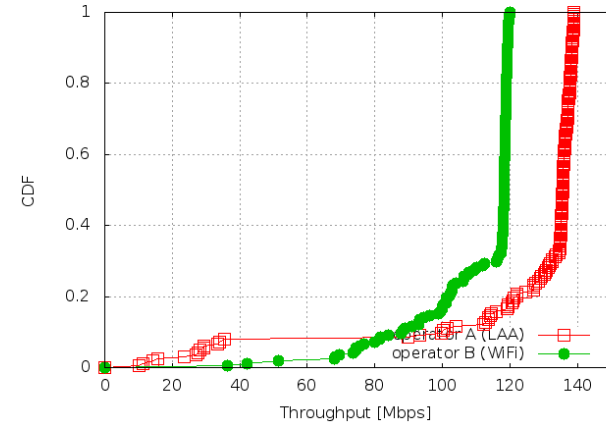

$T=160$ ms

txOp=8,Ftp,2.5,nacks80,20,40,0

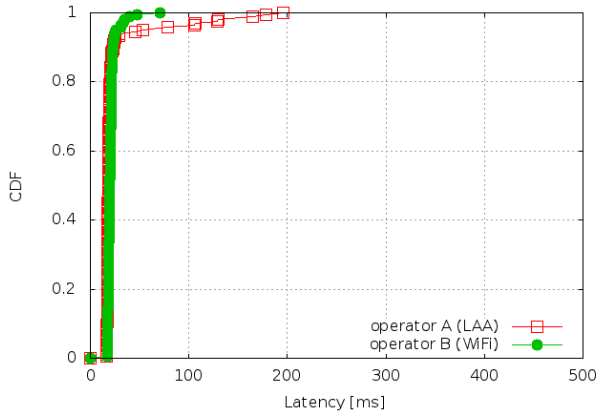

Latency

txOp=8,Ftp,2.5,nacks80,20,80,0

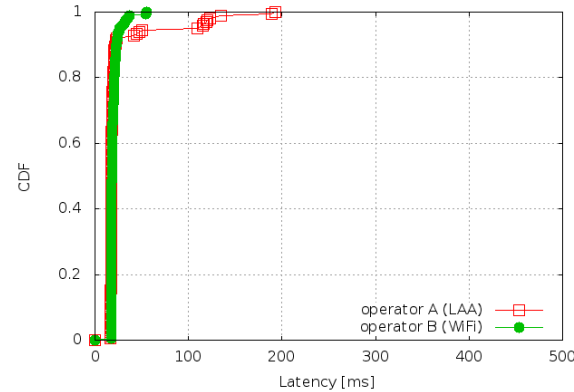

May occupy more airtime than Wi-Fi beacons (0.14 ms every 100 ms) 35

txOp=8,Ftp,2.5,nacks80,20,160,0

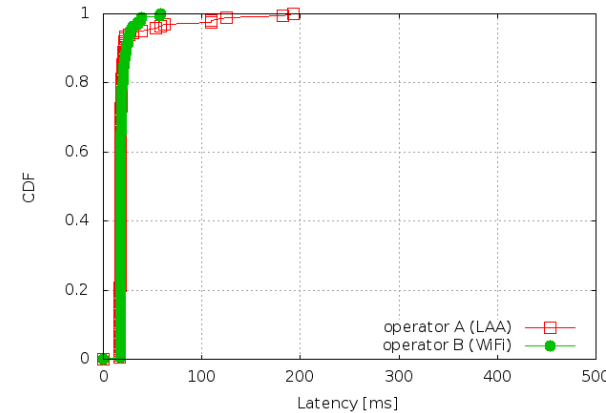

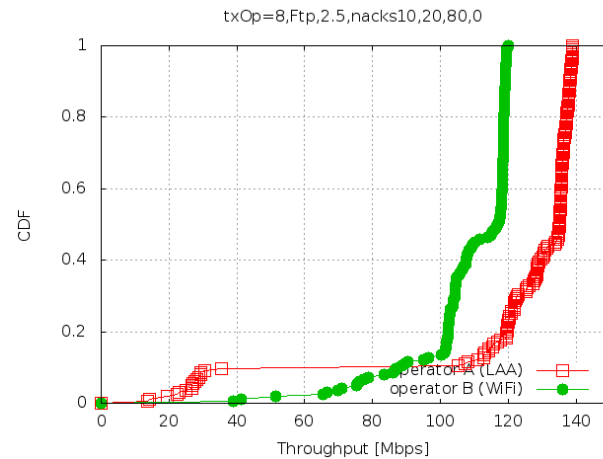
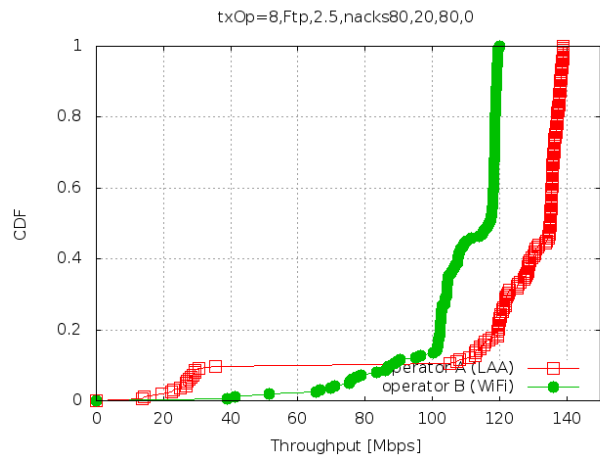

Throughput

Z=80%

Z=10%

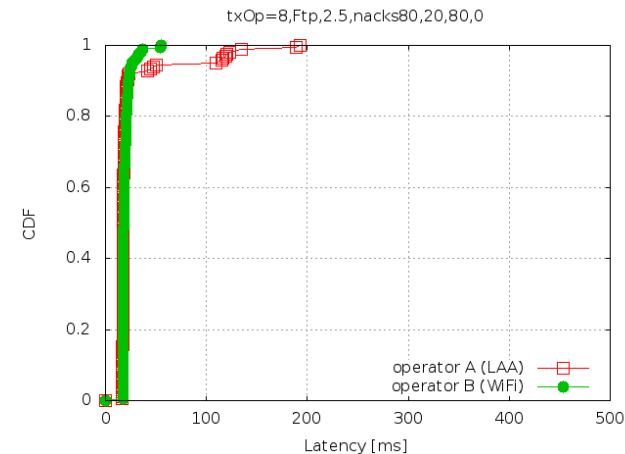
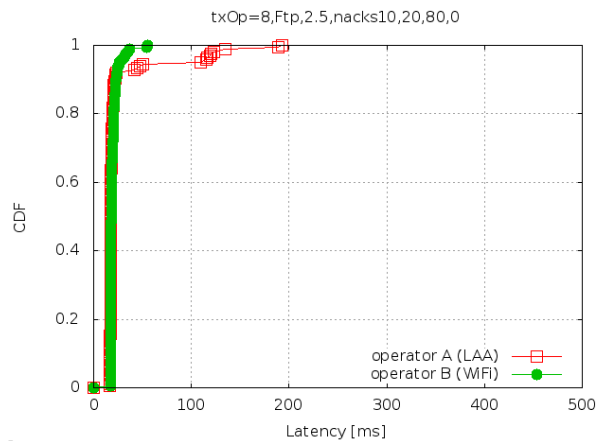

Latency

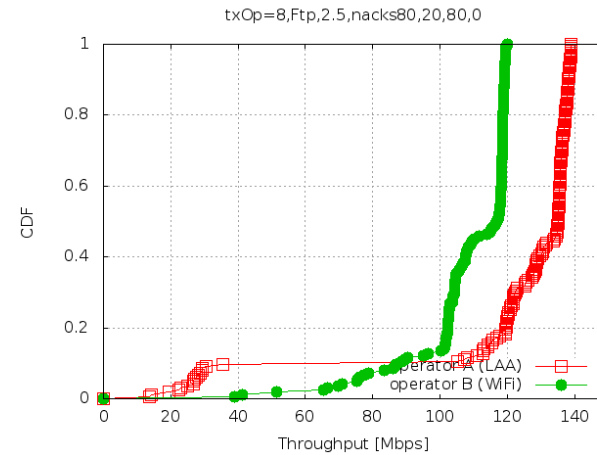
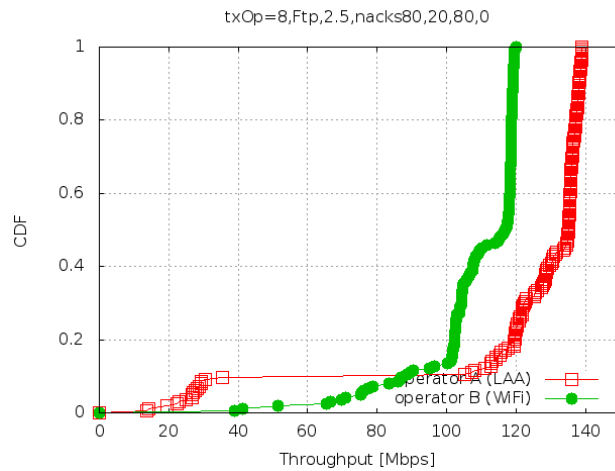

Throughput

CWMmax=63

CWMmax=1023

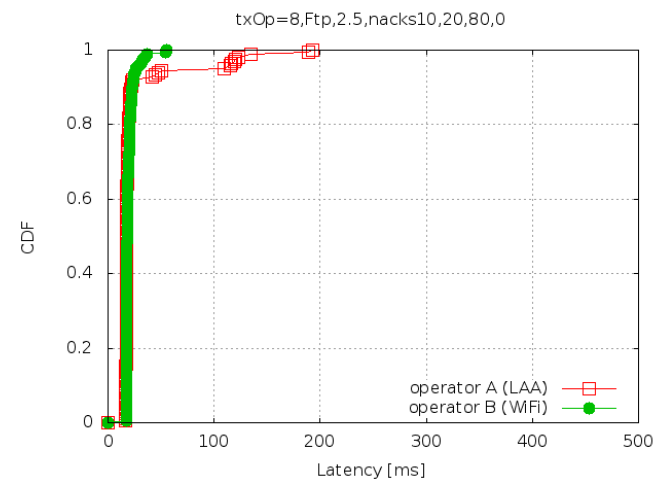
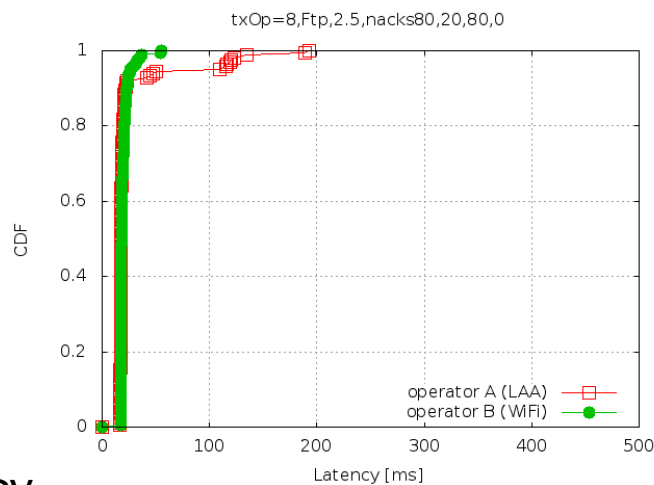

Latency

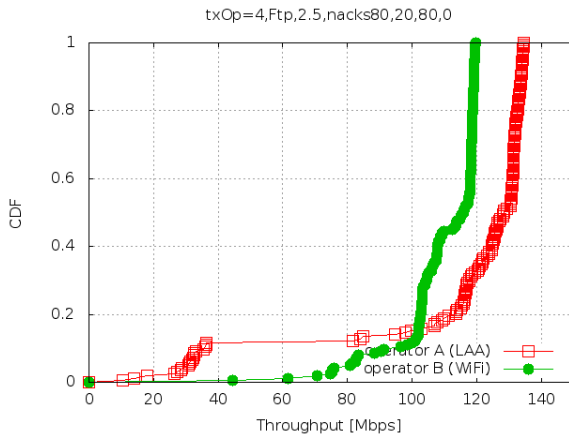

Throughput TxOP=4 ms

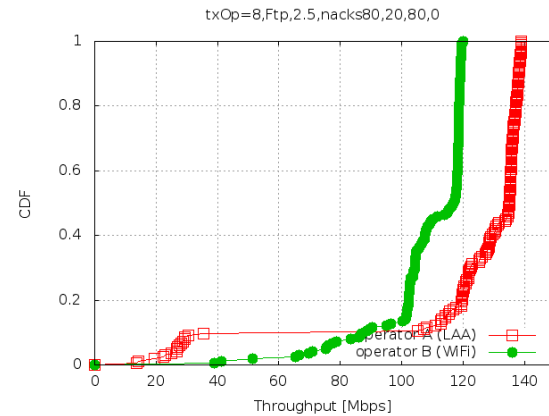

TxOP=8 ms

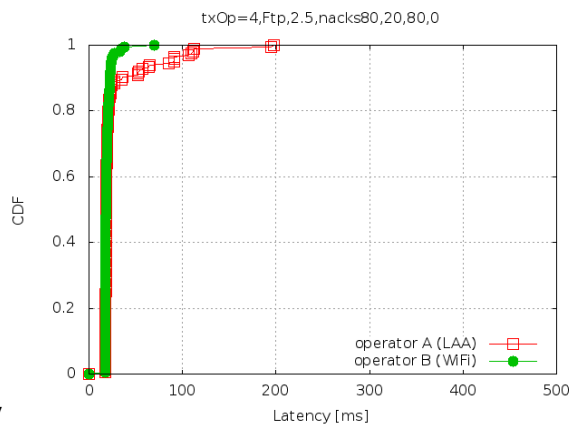

Latency

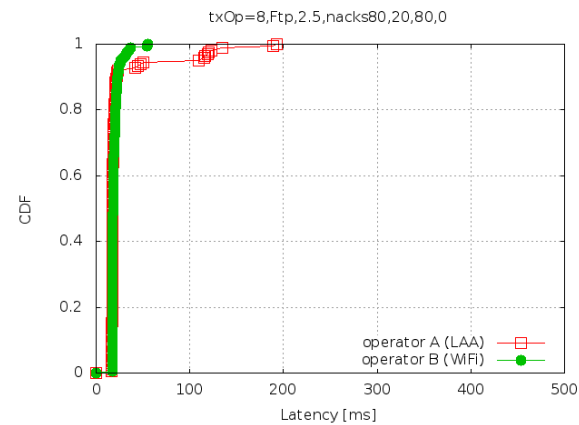

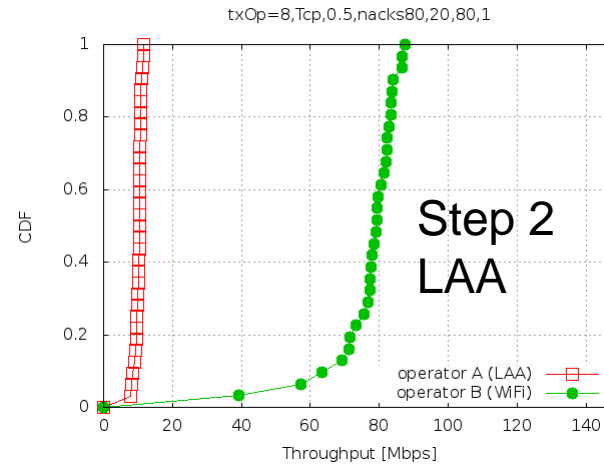
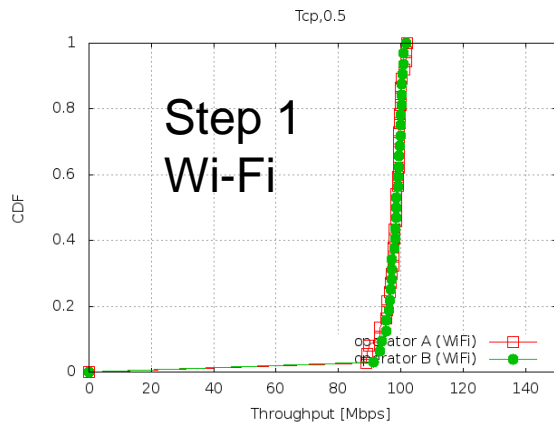

Throughput

$\lambda = 0,5$

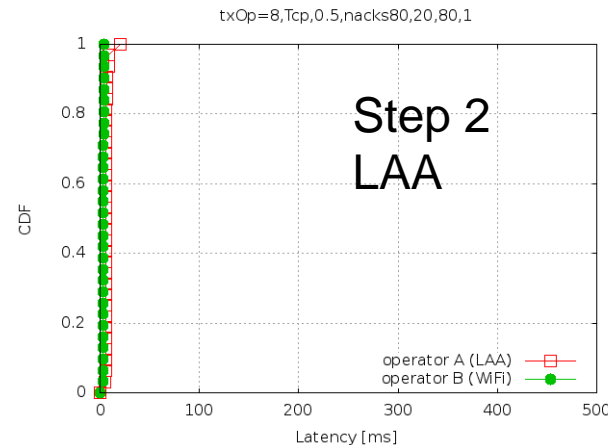
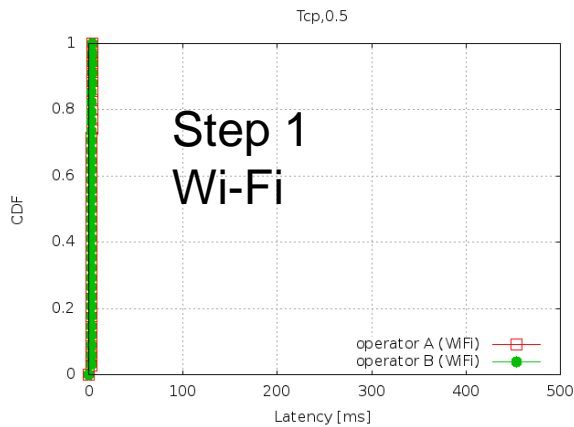

Latency

$\lambda = 0,5$

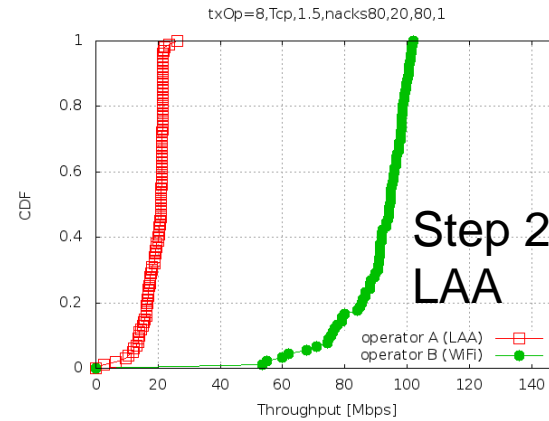
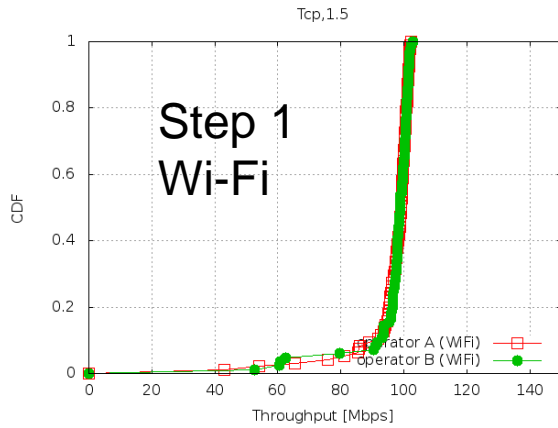

Throughput

$\lambda = 1,5$

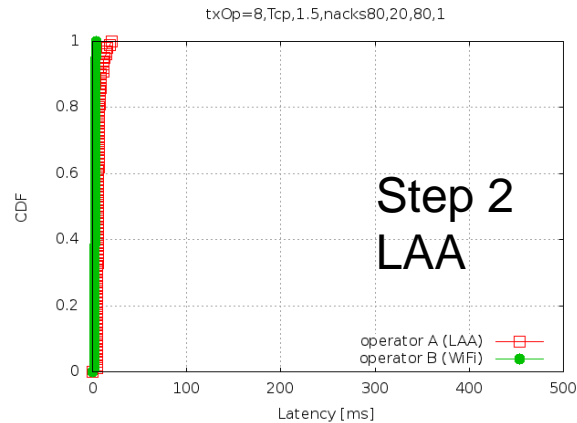
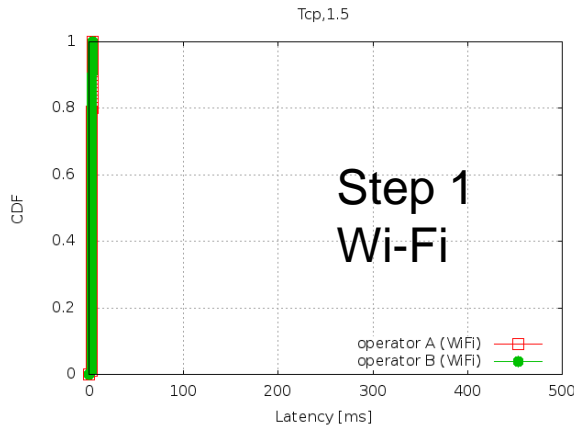

Latency

$\lambda = 1,5$

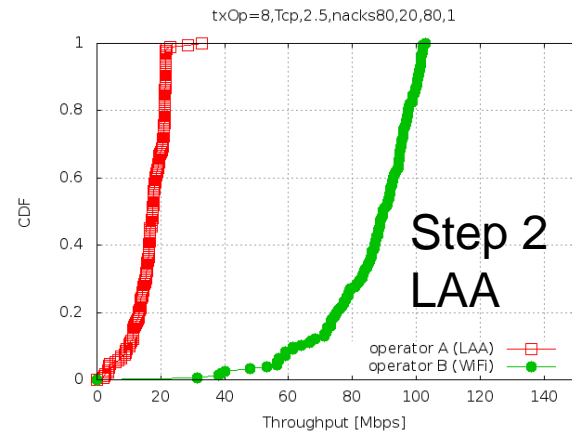
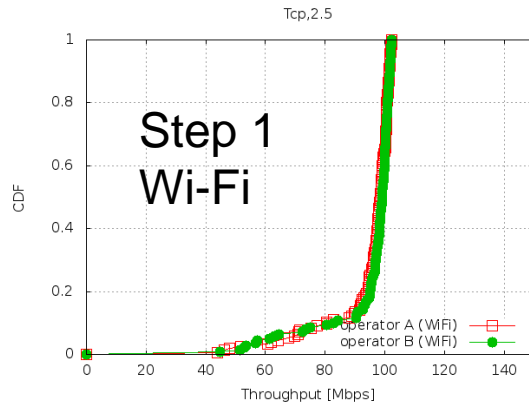

Throughput

$\lambda = 2,5$

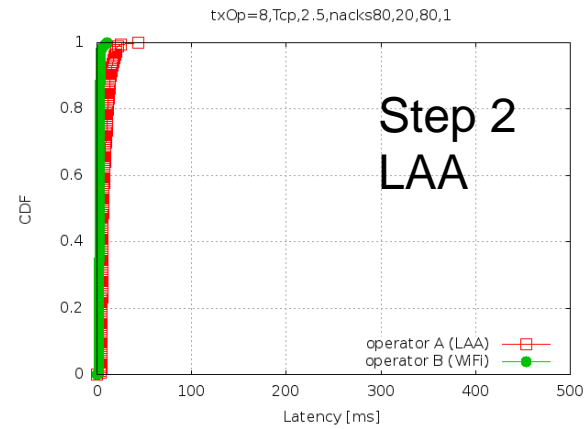
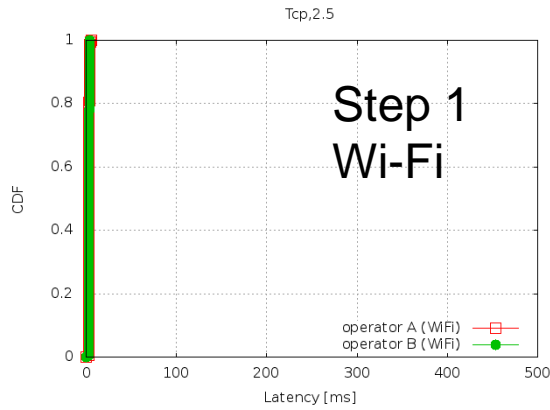

Latency

$\lambda = 2,5$

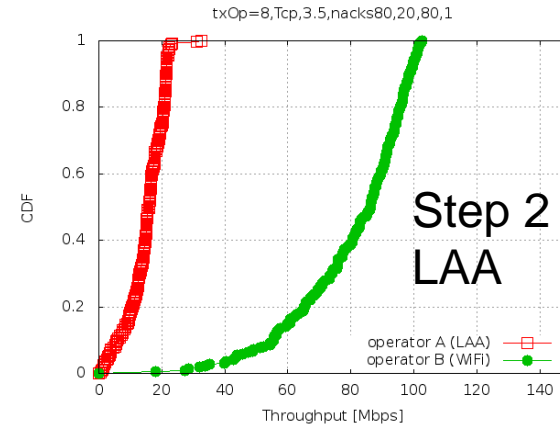
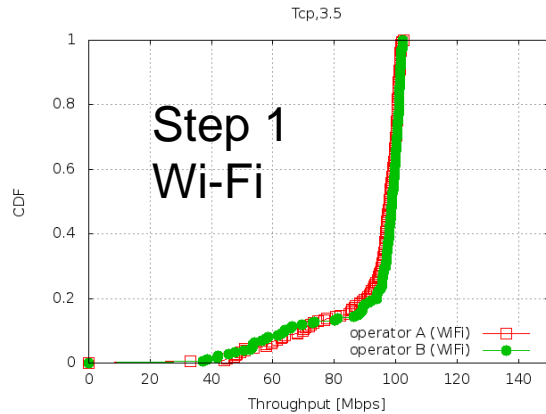

Throughput

$\lambda = 3,5$

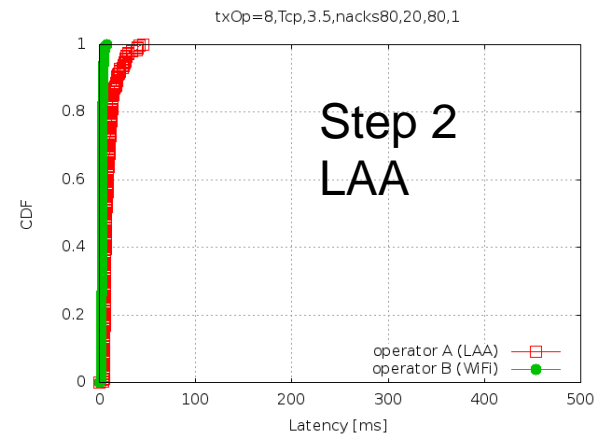
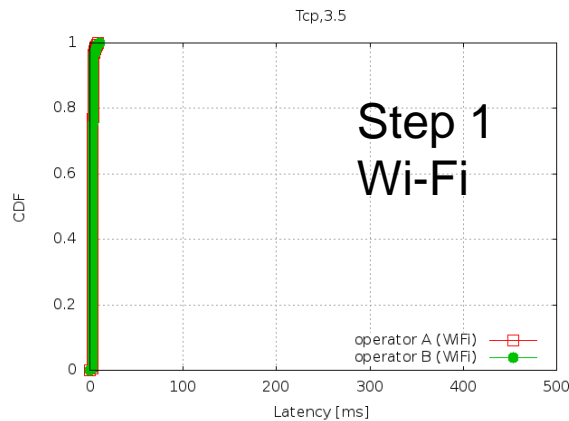

Latency

$\lambda = 3,5$

LAA throughput is low-- is something wrong?

- 3GPP FTP model consists of:
 - File transfers sent at random times according to a Poisson process controlled by parameter Lambda
 - File size 0.5MB, Lambda between 0.5 and 2.5; a Lambda of 2.5 means about one file transfer every 400ms
- TCP transfers of 0.5 MB with TCP segment size of 536 bytes led to about 22 RTTs required over our LAA implementation
 - We therefore configured a default segment size of 1440 bytes and an initial congestion window size of 10 segments, but still many round trip times are required to complete the transfer.
- Each RTT is variable but on the order of 10-30ms: LTE protocol stack introduces very high latencies.
 - This is due by LTE standard times, plus delays and timers introduced by RLC-AM.
 - Those delays introduced by RLC-AM may be optimized searching for tradeoffs, but this would not increase Wi-Fi performance anyway.
 - The delay are accentuated by the fact that there is not traffic in UL direction, so we need to send Buffer Status Report (BSR) every time we need to send UL TCP ACKs
- Overall throughput is then bounded by about 10-20 Mb/s since it takes 400-500ms to complete the transfer

If LAA throughput is so low, why is Wi-Fi impacted?

- The throughput degradation is due to the additional contention that LAA LBT causes because it occupies the channel much more than the corresponding Wi-Fi network.
- LAA LBT takes the channel during more time because it introduces retransmissions from RLC layer, as well as some overhead again from RLC layer, if RLC-AM is considered (STATUS PDU).
- Resources may happen to be used more inefficiently than in Wi-Fi. Small amounts of data and/or control are scheduled inefficiently, since the SF is the minimum granularity for resource allocation.
- In these cases Wi-Fi occupies the channel only for tens of microseconds.

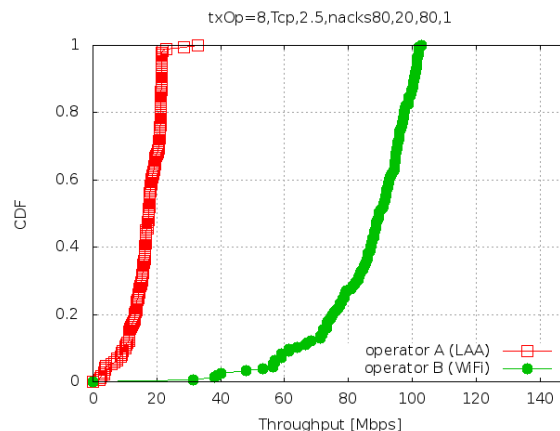
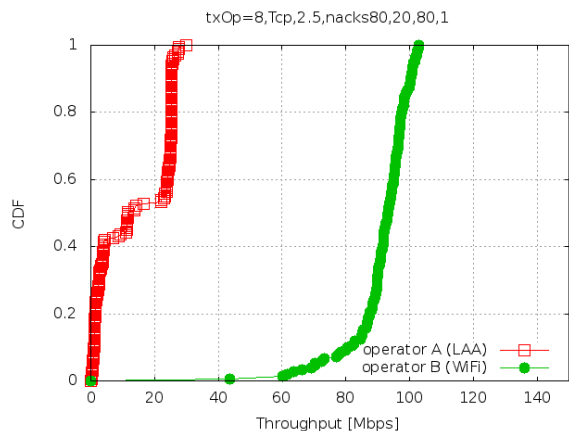

Throughput $\lambda = 2,5$, RLC-UM

$\lambda = 2,5$, RLC-AM

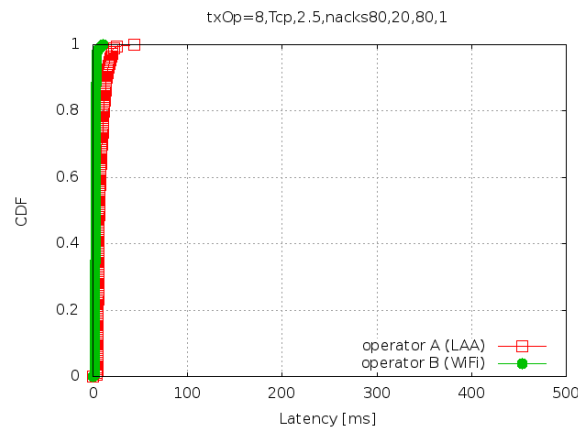
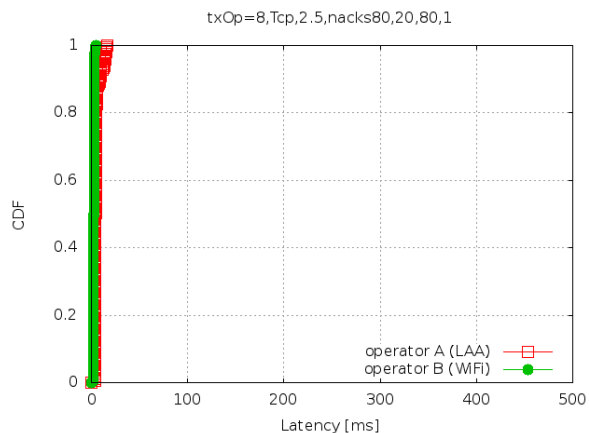

Latency

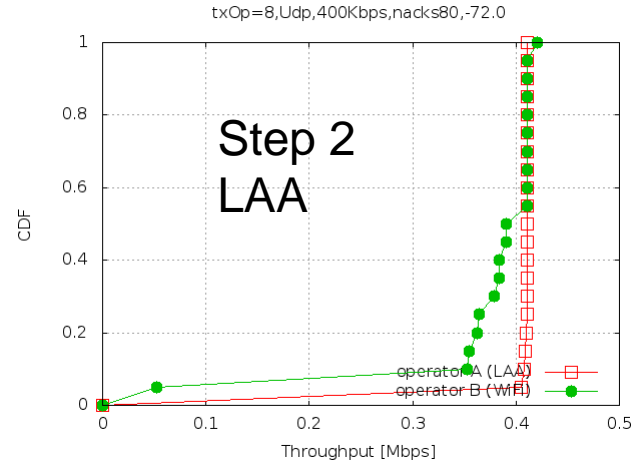
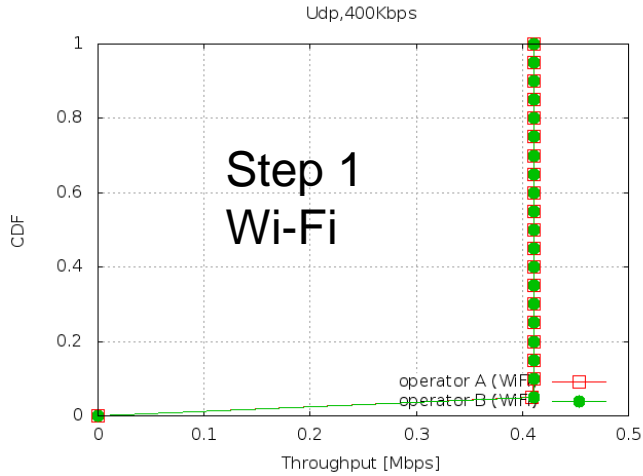

Throughput

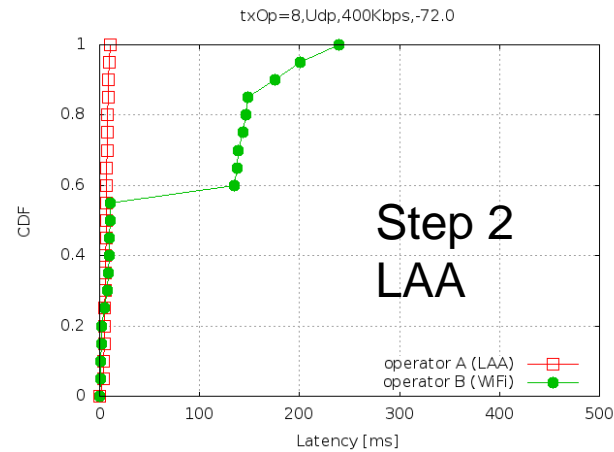
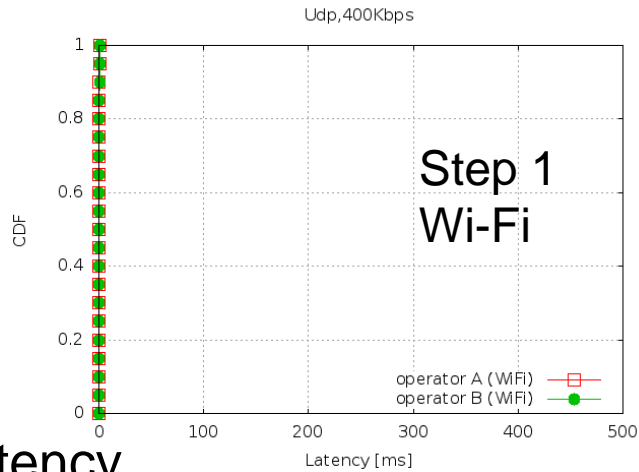

Latency

- This traffic model allows to observe the effect of the transmission granularity difference between LTE and Wi-Fi.
- UDP packets are 1000 Bytes
- At 400 kbps, UDP packets arrive spaced every 20 ms, so LAA does not aggregate in one subframe.
- LAA asks for access, transmits approx 1000 Bytes and leaves the channel.
- The capacity of the subframe is 75Kbit (SISO), so this traffic model makes that the capacity is spared.
- Optimizations at the scheduler are required to deal with these inefficiencies.

- ns-3 logging can be enabled and parsed to find these TCP events; further logging in the LTE LAA stack and on the channel can expose other events

TCP SYN Sent:

4.06492s -1 4.06492 [node 48] TcpL4Protocol:SendPacket(): [LOGIC] TcpL4Protocol 0x1ca80d0 sending seq 0 ack 0 flags 2 data size 0 received after a delay here:

4.068s 8 4.068 [node 8] TcpL4Protocol:Receive(0x1d3dce0, 0x22c1730, tos 0x0 DSCP Default ECN Not-ECT ttl 63 id 0 protocol 6 offset (bytes) 0 flags [none] length: 56 1.0.0.2 > 7.0.0.2, 0x1dd6b80)

Immediately acked:

4.068s 8 4.068 [node 8] TcpL4Protocol:SendPacket(): [LOGIC] TcpL4Protocol 0x1d3dce0 sending seq 0 ack 1 flags 12 data size 0 received here:

4.07993s 48 4.07993 [node 48] TcpL4Protocol:Receive(0x1ca80d0, 0x21bf8b0, tos 0x0 DSCP Default ECN Not-ECT ttl 63 id 0 protocol 6 offset (bytes) 0 flags [none] length: 56 7.0.0.2 > 1.0.0.2, 0x1d821f0)

Then two packets are sent, and the second one acked:

4.07993s 48 4.07993 [node 48] TcpL4Protocol:SendPacket(): [LOGIC] TcpL4Protocol 0x1ca80d0 sending seq 1 ack 1 flags 10 data size 0

4.07993s 48 4.07993 [node 48] TcpL4Protocol:SendPacket(): [LOGIC] TcpL4Protocol 0x1ca80d0 sending seq 1 ack 1 flags 10 data size 536

4.084s 8 4.084 [node 8] TcpL4Protocol:Receive(0x1d3dce0, 0x1e77a00, tos 0x0 DSCP Default ECN Not-ECT ttl 63 id 1 protocol 6 offset (bytes) 0 flags [none] length: 52 1.0.0.2 > 7.0.0.2, 0x1dd6b80)

4.084s 8 4.084 [node 8] TcpL4Protocol:Receive(0x1d3dce0, 0x1e77970, tos 0x0 DSCP Default ECN Not-ECT ttl 63 id 2 protocol 6 offset (bytes) 0 flags [none] length: 588 1.0.0.2 > 7.0.0.2, 0x1dd6b80)

4.084s 8 4.084 [node 8] TcpL4Protocol:SendPacket(): [LOGIC] TcpL4Protocol 0x1d3dce0 sending seq 1 ack 537 flags 10 data size 0

4.11593s 48 4.11593 [node 48] TcpL4Protocol:Receive(0x1ca80d0, 0x1eb99c0, tos 0x0 DSCP Default ECN Not-ECT ttl 63 id 1 protocol 6 offset (bytes) 0 flags [none] length: 52 7.0.0.2 > 1.0.0.2, 0x1d821f0)

- In this example, TCP SYN is sent by backhaul node at time 4.06492s, and received by the UE TCP at time 4.06800s
- TCP SYN is received by the eNB at time 4.06492 (very fast backhaul network) and therefore the ~3ms one-way delay is incurred almost totally from LTE eNB to UE
- 2ms are a MAC to PHY delay in LTE stack
- The actual transmission on the shared downlink channel takes 1ms and starts at time 4.07000s; of this, the first 214 ms is due to LTE control, and 786 ms is available for data

- In this example, TCP SYN ACK is sent by UE node at time 4.06800s, and received by the backhaul TCP at time 4.07993s (~12 ms later)
- 12 ms is the typical one-way delay. When the UE sees the ACK in the RLC queue, and consequently wants to send something, the RLC sends a Buffer Status Report (BSR) to the eNB MAC, basically saying that it has data to transmit. Since this moment, it takes 4 msec for the BSR to reach the eNB MAC (this is by standard). Then, the eNB receives the BSR and has to do the schedule and generate an UL DCI. This takes 4 msec to be received at the UE MAC. When the UE receives the UL DCI, it takes again 4 msec before the SYN/ACK is received at the remote host.

- In summary, TCP transfer of 0.5 MB with TCP segment size of 536 bytes leads to about 22 RTTs required over our LAA LBT implementation
 - Each RTT is variable but on the order of 15ms
 - Overall throughput is bounded then by about 10 Mb/s since it takes 400-500ms to complete the transfer
- If TCP segment size is increased to 1440 bytes and initial congestion window is increased to 10 segments, then the number of RTT to complete the transfer is reduced to approx 11.
 - This makes that the LAA throughput increases and is bounded by 20 Mb/s approx.

- Coexistence between LAA (specified by 3GPP in Release 13) and Wi-Fi, in the 5 GHz unlicensed band, is a current research topic
- We report here on recent extensions to the [ns-3 simulator](#) to model such coexistence.
- We developed extensions according to the simulation methodology documented in 3GPP's technical report TR36.889
- ns-3 is a system simulator allowing for [full-protocol](#) stack evaluation of coexistence, and is available as free open source software.
- Use of a full stack simulator allows researchers to explore the impact of higher-layer protocol patterns that may influence coexistence performance.
- Use of an open simulator allows researchers to fully replicate results and to collaborate on and validate the protocol models in use.